



СВЕРЛА / РАЗВЕРТКИ

2022











**КАТАЛОГ STAMO
РЕЗЬБОНАРЕЗНОЙ ИНСТРУМЕНТ**

M
MF
G-Rp
UNC
UNF
UNEF-UNC-UN
NPSM-NPSF
Rc-NPT-NPTF
BSW-PG-Tr-Rd
EG M
Раскатники
Резьбовые фрезы
Плашки
СОЖ
Нарезание резьбы
токарным методом
Контроль резьбы
Резьбовая оснастка
Сверла под резьбу









**КАТАЛОГ STAMO
РЕЗЬБОНАРЕЗНОЙ ИНСТРУМЕНТ**

MINICUT - Токарная обработка отверстий от \varnothing 7,0 мм 6
ULTRAMINI - Токарная обработка отверстий от \varnothing 0,2 мм 42
Токарная обработка многогранными пластинами
MINIMILL - Фрезерная обработка методом круговой интерполяции
Микрофрезерование от M1
Корпусные и дисковые фрезы
Долбяки - Обработка шпоночных и шлицевых пазов
SWISSLINE - токарная обработка на автоматах продольного точения

	<p>СВЕРЛА ИЗ БЫСТРОРЕЖУЩЕЙ СТАЛИ HSS И HSSE</p>	<p>3xD из быстрорежущей стали HSS и HSSE 5xD из быстрорежущей стали HSS 5xD из быстрорежущей стали HSSE, M42 10xD из быстрорежущей стали HSS, HSSE 15xD из быстрорежущей стали HSS, HSSE 20xD из быстрорежущей стали HSS, HSSE 25xD из быстрорежущей стали HSS, HSSE >40xD из быстрорежущей стали HSS, HSSE Для кондукторных втулок С усиленным хвостовиком из быстрорежущей стали HSSE Ступенчатые сверла</p>	<p>стр 4</p>	
	<p>СВЕРЛА С КОНУСОМ МОРЗЕ</p>	<p>С конусом морзе 5-10xD из быстрорежущей стали HSS, HSSE С конусом морзе 15-50xD из быстрорежущей стали HSS, HSSE</p>	<p>стр 65</p>	
	<p>ЦЕНТРОВОЧНЫЕ СВЕРЛА. ЗЕНКОВКИ</p>	<p>Центровочные сверла двухсторонние из HSS и HSSE. Форма A Центровочные сверла двухсторонние из твердого сплава. форма A Центровочные сверла двухсторонние из твердого сплава. форма R Режимы резания. Центровочные сверла двухсторонние Центровочные сверла для станков ЧПУ 90° из быстрорежущей стали Центровочные сверла для станков ЧПУ 120° из быстрорежущей стали Центровочные сверла для станков ЧПУ 90°, 120°, 142° твердосплавные Режимы резания. Центровочные сверла ЧПУ Конические зенковки. Цилиндрический хвостовик. 60°, 75°, 80°, 82°, 120°. DIN334 Конические зенковки 90°. Цилиндрический хвостовик. DIN335-C Конические зенковки 90° удлиненные. Цилиндрический хвостовик. DIN335-C Конические зенковки 60°, 90°. Хвостовик конус Морзе. DIN335 Режимы резания. Зенковки</p>	<p>стр 83</p>	
	<p>СВЕРЛА ТВЕРДОСПЛАВНЫЕ</p>	<p>Твердосплавные 3xD - 5xD Твердосплавные HPC 3xD - 7xD Твердосплавные высокопроизводительные HPC для нержавеющей стали Твердосплавные для закаленных материалов Твердосплавное сверло с углом при вершине 180° Твердосплавные высокопроизводительные HPC удлиненные 12xD - 40xD</p>	<p>стр 99</p>	
	<p>МИКРОСВЕРЛА</p>	<p>Микросверла из быстрорежущей стали HSSE-PM Твердосплавные микросверла 3xD - 8xD Микросверла твердосплавные</p>	<p>стр 123</p>	
	<p>СВЕРЛА ПУШЕЧНЫЕ</p>	<p>Сверла пушечные однолезвийные твердосплавные Сверла пушечные однолезвийные с напайной твердосплавной головкой Сверла пушечные сверхдлинные, однолезвийные с напайной твердосплавной головкой</p>	<p>стр 140</p>	
	<p>ФРЕЗЕРНЫЙ ИНСТРУМЕНТ</p>	<p>Фрезы гравировальные твердосплавные Фрезы фасочные твердосплавные фрезы Фрезы многофункциональные фрезы Фрезы vhm с обратным радиусом для скругления кромок и снятия заусенцев Фрезы hse с обратным радиусом для скругления кромок и снятия заусенцев Фрезы режимы резания: фасочные фрезы черновая обработка; фасочные фрезы чистовая обработка; многофункциональные фрезы Фрезы концевые трехзубые с центральным резом Фрезы шпоночные двухзубые с центральным резом Фрезы пазовые трехзубые с центральным резом Фрезы шпоночные универсальные Фрезы шпоночные высокопроизводительные Фрезы шпоночные радиусные Фрезы сферические 2-х и 4-зубые din 65271 с центральным резом Техническая часть: режимы резания. Высокопроизводительное и универсальное фрезерование</p>	<p>стр 156</p>	
	<p>РАЗВЕРТКИ</p>	<p>Развертки: техническая информация Развертки vhm для станков чпу Развертки машинные vhm Развертки vhm Высокопроизводительные развертки vhm Машинные развертки vhm хвостовик с конусом морзе. универсальное применение Автоматные развертки vhm Ручные развертки hss Машинные развертки hse для станков с чпу Машинные развертки hse Автоматные развертки hse Машинные развертки hse спираль 45° Машинные развертки hse хвостовик с конусом морзе Ручные конические развертки hse Машинные конические развертки hse Ручные развертки vhm Машинные насадные развертки hse, vhm Развертки. режимы резания</p>	<p>стр 178</p>	
	<p>ДИСКОВЫЕ ПИЛЫ</p>	<p>Дисковые пилы. Техническая информация Дисковые пилы HSS Дисковые пилы VHM</p>	<p>стр 236</p>	

СВЕРЛА

	СВЕРЛА ИЗ БЫСТРОРЕЖУЩЕЙ СТАЛИ HSS И HSSE	<p>3xD из быстрорежущей стали HSS и HSSE 5xD из быстрорежущей стали HSS 5xD из быстрорежущей стали HSSE, M42 10xD из быстрорежущей стали HSS, HSSE 15xD из быстрорежущей стали HSS, HSSE 20xD из быстрорежущей стали HSS, HSSE 25xD из быстрорежущей стали HSS, HSSE >40xD из быстрорежущей стали HSS, HSSE Для кондукторных втулок С усиленным хвостовиком из быстрорежущей стали HSSE Ступенчатые сверла</p>	стр 4	
	СВЕРЛА С КОНУСОМ МОРЗЕ	<p>С конусом морзе 5-10xD из быстрорежущей стали HSS, HSSE С конусом морзе 15-50xD из быстрорежущей стали HSS, HSSE</p>	стр 65	
	ЦЕНТРОВОЧНЫЕ СВЕРЛА. ЗЕНКОВКИ	<p>Центровочные сверла двухсторонние из HSS и HSSE. Форма А Центровочные сверла двухсторонние из твердого сплава. форма А Центровочные сверла двухсторонние из твердого сплава. форма R Режимы резания. Центровочные сверла двухсторонние Центровочные сверла для станков ЧПУ 90° из быстрорежущей стали Центровочные сверла для станков ЧПУ 120° из быстрорежущей стали Центровочные сверла для станков ЧПУ 90°, 120°, 142° твердосплавные Режимы резания. Центровочные сверла ЧПУ Конические зенковки. Цилиндрический хвостовик. 60°, 75°, 80°, 82°, 120°. DIN334 Конические зенковки 90°. Цилиндрический хвостовик. DIN335-C Конические зенковки 90° удлиненные. Цилиндрический хвостовик. DIN335-C Конические зенковки 60°, 90°. Хвостовик конус Морзе. DIN335 Режимы резания. Зенковки</p>	стр 83	
	СВЕРЛА ТВЕРДОСПЛАВНЫЕ	<p>Твердосплавные 3xD - 5xD Твердосплавные НРС 3xD - 7xD Твердосплавные высокопроизводительные НРС для нержавеющей стали Твердосплавные для закаленных материалов Твердосплавное сверло с углом при вершине 180° Твердосплавные высокопроизводительные НРС удлиненные 12xD - 40xD</p>	стр 99	
	МИКРОСВЕРЛА	<p>Микросверла из быстрорежущей стали HSSE-PM Твердосплавные микросверла 3xD - 8xD Микросверла твердосплавные</p>	стр 123	
	СВЕРЛА ПУШЕЧНЫЕ	<p>Сверла пушечные однолезвийные твердосплавные Сверла пушечные однолезвийные с напайной твердосплавной головкой Сверла пушечные сверхдлинные, однолезвийные с напайной твердосплавной головкой</p>	стр 140	

СВЕРЛА

ИЗ БЫСТРОРЕЖУЩЕЙ СТАЛИ HSS И HSSE

Сверла
HSS, HSSE



универсальное применение

Система обозначений	
d1	Диаметр режущей части, мм
Лобц	Общая длина, мм
l2	Максимальная глубина резания, мм

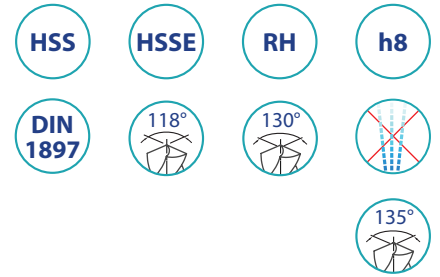
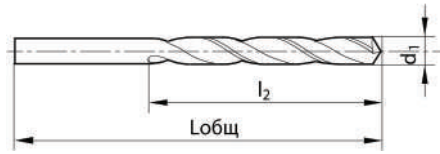

сверла
HSS, HSSE

HSS

HSSE

M42



Глубина обработки	3xD	3xD	3xD	3xD	3xD	3xD	3xD	3xD	3xD	3xD	3xD	3xD	
Материал	HSS	HSS	HSS	HSS	HSS	HSSE	HSSE	HSSE	HSSE	HSSE	HSSE	M42	
Покрытие	BR	V	Nit	TIN	TiAIN	BR	BR	TIN	V	TIN	TiAIN	BR	
Угол при вершине	118°	118°	130°	118°	118°	130°	118°	118°	118°	130°	130°	135°	
Тип						Va	uni	uni	Va			uni	
Группы обрабатываемых материалов Основное применение	P	•	•	•	•	○	•	•	•	•	•	•	
	M					•	•	•	•	•	•	○	
	N	•	•	•	•	○	○	•	○	○	○	•	
	K	•	•	•	•	•	•	•	•	•	•	•	•
	S						○			•	•	•	
H									○	○	○		

d1	Лобц	l2	Артикулы												
			STD1116	STD1110	STD2110	STD7110	STD7117	STD7210	STD3210	STD2210	STD1210	STD7216	STD7215	STD3510	
0,4	19	2									•	•			
0,5	20	3		•							•				
0,6	21	3,5		•							•				
0,65	22	4									•				
0,7	23	4,5	•	•								•			
0,75												•			
0,8	24	5	•	•							•				
0,85				•											
0,86												•			
0,87	25	5,5									•				
0,9				•							•				
0,95												•			
1	26	6	•	•		•	•	•	•	•	•	•	•	•	
1,03											•				
1,05												•			
1,1	28	7	•	•				•	•	•	•	•	•	•	
1,15											•				
1,2						•	•					•			•
1,25	30	8	•	•							•			•	
1,3				•	•		•	•	•	•	•	•	•	•	
1,35					•	•						•			•
1,4	32	9		•				•	•	•	•	•	•	•	
1,45											•			•	
1,5				•	•	•	•	•	•	•	•	•	•	•	•
1,55	34	10		•							•			•	
1,6				•	•	•	•	•	•	•	•	•	•	•	
1,65					•	•						•			•
1,7					•	•		•	•	•	•	•	•	•	•
1,75	36	11		•							•			•	
1,8				•	•	•	•	•	•	•	•	•	•	•	
1,85					•	•						•			•
1,9				•	•	•	•	•	•	•	•	•	•	•	•

универсальное применение

сверла
HSS, HSSE

Система обозначений	
d1	Диаметр режущей части, мм
Лобц	Общая длина, мм
l2	Максимальная глубина резания, мм

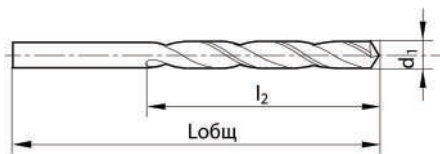

HSS

HSSE

RH

h8

DIN 1897

118°

130°

135°

HSS

HSSE

M42



Глубина обработки	3xD	3xD	3xD	3xD	3xD	3xD	3xD	3xD	3xD	3xD	3xD	3xD
Материал	HSS	HSS	HSS	HSS	HSS	HSSE	HSSE	HSSE	HSSE	HSSE	HSSE	M42
Покрытие	BR	V	Nit	TIN	TiAIN	BR	BR	TIN	V	TIN	TiAIN	BR
Угол при вершине	118°	118°	130°	118°	118°	130°	118°	118°	118°	130°	130°	135°
Тип						Va	uni	uni	Va			uni
Группы обрабатываемых материалов Основное применение	P	•	•	•	•	○	•	•	•	•	•	•
	M					○	•	•	•	•	•	○
	N	•	•	•	•	○	○	•	○	○	○	•
	K	•	•	•	•	•	•	•	•	•	•	•
	S						○			•	•	•
H									○	○	○	

d1	Лобц	l2	Артикулы													
			STD1116	STD1110	STD2110	STD7110	STD7117	STD7210	STD3210	STD2210	STD1210	STD7216	STD7215	STD3510		
1,95	38	12		•								•				
1,97													•			
1,98														•		
2					•	•	•	•	•	•	•	•	•	•	•	•
2,03																
2,05																
2,1	40	13	•	•	•	•	•	•	•	•	•	•	•	•		
2,2			•	•	•	•	•	•	•	•	•	•	•	•		
2,25																
2,3			•	•	•	•	•	•	•	•	•	•	•	•	•	
2,35																
2,4	43	14	•	•	•	•	•	•	•	•	•	•	•	•		
2,45																
2,47																
2,5			•	•	•	•	•	•	•	•	•	•	•	•	•	
2,55																
2,6																
2,65																
2,7	46	16	•	•	•	•	•	•	•	•	•	•	•	•		
2,75																
2,8			•	•	•	•	•	•	•	•	•	•	•	•	•	
2,9			•	•	•	•	•	•	•	•	•	•	•	•	•	
2,95																
3																
3,05	49	18	•	•	•	•	•	•	•	•	•	•	•	•		
3,1			•	•	•	•	•	•	•	•	•	•	•	•	•	
3,15																
3,2			•	•	•	•	•	•	•	•	•	•	•	•	•	
3,25																
3,3	•	•	•	•	•	•	•	•	•	•	•	•	•	•		
3,35																

универсальное применение

Система обозначений	
d1	Диаметр режущей части, мм
Лобц	Общая длина, мм
l2	Максимальная глубина резания, мм

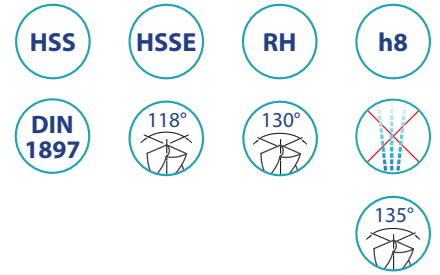
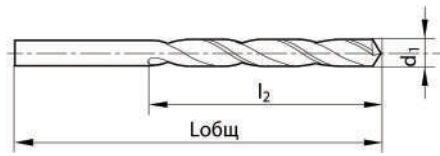

сверла
HSS, HSSE

HSS

HSSE

M42



Глубина обработки	3xD	3xD	3xD	3xD	3xD	3xD	3xD	3xD	3xD	3xD	3xD	3xD
Материал	HSS	HSS	HSS	HSS	HSS	HSSE	HSSE	HSSE	HSSE	HSSE	HSSE	M42
Покрытие	BR	V	Nit	TIN	TiAIN	BR	BR	TIN	V	TIN	TiAIN	BR
Угол при вершине	118°	118°	130°	118°	118°	130°	118°	118°	118°	130°	130°	135°
Тип						Va	uni	uni	Va			uni
Группы обрабатываемых материалов Основное применение	P	•	•	•	•	•	•	•	•	•	•	•
	M	•	•	•	•	•	•	•	•	•	•	•
	N	•	•	•	•	•	•	•	•	•	•	•
	K	•	•	•	•	•	•	•	•	•	•	•
	S						•			•		•
H									•	•	•	

d1	Лобц	l2	Артикулы											
			STD1116	STD1110	STD2110	STD7110	STD7117	STD7210	STD3210	STD2210	STD1210	STD7216	STD7215	STD3510
3,4	52	20	•	•		•	•		•	•	•	•	•	•
3,45			•	•		•	•		•	•	•	•	•	•
3,5			•	•	•	•	•	•	•	•	•	•	•	•
3,55														
3,6			•	•		•	•	•	•	•	•	•	•	•
3,65			•	•		•	•	•	•	•	•	•	•	•
3,7			•	•	•	•	•	•	•	•	•	•	•	•
3,75			•	•		•	•	•	•	•	•	•	•	•
3,8						•	•	•	•	•	•	•	•	•
3,85						•	•	•	•	•	•	•	•	•
3,9	55	22	•	•		•	•		•	•	•	•	•	
4			•	•	•	•	•	•	•	•	•	•	•	
4,1			•	•		•	•	•	•	•	•	•	•	
4,2			•	•	•	•	•	•	•	•	•	•	•	
4,25			•	•		•	•	•	•	•	•	•	•	
4,3			•	•	•	•	•	•	•	•	•	•	•	
4,4			•	•		•	•	•	•	•	•	•	•	
4,5			•	•	•	•	•	•	•	•	•	•	•	
4,6			•	•	•	•	•	•	•	•	•	•	•	
4,65			•	•		•	•	•	•	•	•	•	•	
4,7				•	•	•	•	•	•	•	•			
4,75	•	•		•	•	•	•	•	•	•	•			
4,8				•	•	•	•	•	•	•	•			
4,85	•	•		•	•	•	•	•	•	•	•			
4,9				•	•	•	•	•	•	•	•			
4,95	•	•	•	•	•	•	•	•	•	•	•			
5	62	26	•	•		•	•		•	•	•	•	•	
5,05			•	•		•	•		•	•	•	•	•	
5,1			•	•	•	•	•	•	•	•	•	•	•	
5,2			•	•		•	•	•	•	•	•	•	•	
5,25			•	•	•	•	•	•	•	•	•	•	•	
5,3			•	•		•	•	•	•	•	•	•	•	

универсальное применение

Система обозначений

d1	Диаметр режущей части, мм
Лобц	Общая длина, мм
l2	Максимальная глубина резания, мм

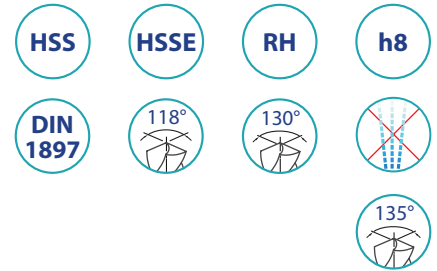
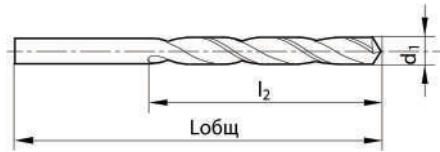

HSS

HSSE

M42



Глубина обработки	3xD	3xD	3xD	3xD	3xD	3xD	3xD	3xD	3xD	3xD	3xD	3xD	
Материал	HSS	HSS	HSS	HSS	HSS	HSSE	HSSE	HSSE	HSSE	HSSE	HSSE	M42	
Покрытие	BR	V	Nit	TIN	TiAIN	BR	BR	TIN	V	TIN	TiAIN	BR	
Угол при вершине	118°	118°	130°	118°	118°	130°	118°	118°	118°	130°	130°	135°	
Тип						Va	uni	uni	Va			uni	
Группы обрабатываемых материалов Основное применение	P	•	•	•	•	○	•	•	•	•	•	•	
	M					○	•	•	•	•	•	○	
	N	•	•	•	•	○	○	•	○	○	○	•	
	K	•	•	•	•	•	•	•	•	•	•	•	•
	S						○			•	•	•	
H									○	○	○		

d1	Лобц	l2	Артикулы												
			STD1116	STD1110	STD2110	STD7110	STD7117	STD7210	STD3210	STD2210	STD1210	STD7216	STD7215	STD3510	
5,4	66	28		•	•	•	•		•	•	•	•	•	•	
5,5			•	•	•	•		•	•	•	•	•	•	•	
5,55												•			
5,6			•	•	•	•		•	•	•	•	•	•	•	•
5,7			•	•	•	•		•	•	•	•	•	•	•	•
5,75			•	•	•	•		•	•	•	•	•	•	•	•
5,8			•	•	•	•		•	•	•	•	•	•	•	•
5,85			•	•	•	•		•	•	•	•	•	•	•	•
5,9			•	•	•	•		•	•	•	•	•	•	•	•
5,95			•	•	•	•		•	•	•	•	•	•	•	•
6	•	•	•	•		•	•	•	•	•	•	•	•		
6,1	70	31	•	•	•	•		•	•	•	•	•	•	•	
6,15			•	•	•	•		•	•	•	•	•	•	•	
6,2			•	•	•	•		•	•	•	•	•	•	•	
6,25			•	•	•	•		•	•	•	•	•	•	•	
6,3			•	•	•	•		•	•	•	•	•	•	•	
6,35			•	•	•	•		•	•	•	•	•	•	•	
6,4			•	•	•	•		•	•	•	•	•	•	•	
6,5			•	•	•	•		•	•	•	•	•	•	•	
6,6			•	•	•	•		•	•	•	•	•	•	•	
6,7			•	•	•	•		•	•	•	•	•	•	•	
6,75	•	•	•	•		•	•	•	•	•	•	•			
6,8	74	34	•	•	•	•		•	•	•	•	•	•	•	
6,9			•	•	•	•		•	•	•	•	•	•	•	•
7			•	•	•	•		•	•	•	•	•	•	•	•
7,1			•	•	•	•		•	•	•	•	•	•	•	•
7,2			•	•	•	•		•	•	•	•	•	•	•	•
7,3			•	•	•	•		•	•	•	•	•	•	•	•
7,4			•	•	•	•		•	•	•	•	•	•	•	•
7,5			•	•	•	•		•	•	•	•	•	•	•	•

универсальное применение

Система обозначений	
d1	Диаметр режущей части, мм
Лобц	Общая длина, мм
l2	Максимальная глубина резания, мм

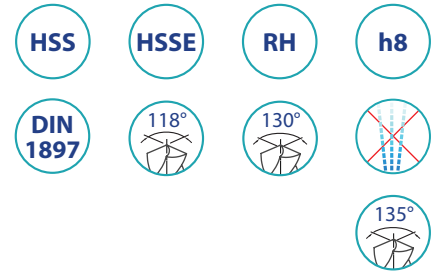
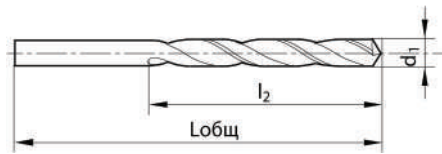

сверла
HSS, HSSE

HSS

HSSE

M42



Глубина обработки	3xD	3xD	3xD	3xD	3xD	3xD	3xD	3xD	3xD	3xD	3xD	3xD
Материал	HSS	HSS	HSS	HSS	HSS	HSSE	HSSE	HSSE	HSSE	HSSE	HSSE	M42
Покрытие	BR	V	Nit	TIN	TiAIN	BR	BR	TIN	V	TIN	TiAIN	BR
Угол при вершине	118°	118°	130°	118°	118°	130°	118°	118°	118°	130°	130°	135°
Тип						Va	uni	uni	Va			uni
Группы обрабатываемых материалов Основное применение	P	•	•	•	•	•	•	•	•	•	•	•
	M	•	•	•	•	•	•	•	•	•	•	•
	N	•	•	•	•	•	•	•	•	•	•	•
	K	•	•	•	•	•	•	•	•	•	•	•
	S						•			•		•
H									•	•	•	•

d1	Лобц	l2	Артикулы																
			STD1116	STD1110	STD2110	STD7110	STD7117	STD7210	STD3210	STD2210	STD1210	STD7216	STD7215	STD3510					
7,6	79	37		•		•	•	•	•	•	•	•	•	•	•				
7,7				•		•			•	•	•	•	•	•	•	•			
7,75					•		•												
7,8					•		•			•	•	•	•	•	•	•			
7,9					•		•			•	•	•	•	•	•	•			
8					•		•			•	•	•	•	•	•	•			
8,1					•		•			•	•	•	•	•	•	•			
8,2					•		•			•	•	•	•	•	•	•			
8,25																			
8,3					•		•			•	•	•	•	•	•	•	•		
8,4					•		•			•	•	•	•	•	•	•	•		
8,5					•		•			•	•	•	•	•	•	•	•		
8,6			84	40															
8,7																			
8,75																			
8,8																			
8,9																			
9					•		•			•	•	•	•	•	•	•	•		
9,1					•		•			•	•	•	•	•	•	•	•		
9,2					•		•			•	•	•	•	•	•	•	•		
9,25																			
9,3							•			•	•	•	•	•	•	•	•		
9,4							•			•	•	•	•	•	•	•	•		
9,5							•			•	•	•	•	•	•	•	•		
9,6	89	43																	
9,7																			
9,75																			
9,8									•			•	•	•	•	•	•	•	•
9,9							•			•	•	•	•	•	•	•	•		
10					•		•			•	•	•	•	•	•	•	•		
10,05							•			•	•	•	•	•	•	•	•		
10,1							•			•	•	•	•	•	•	•	•		
10,2					•		•			•	•	•	•	•	•	•	•		

универсальное применение

Система обозначений

d1	Диаметр режущей части, мм
Лобц	Общая длина, мм
l2	Максимальная глубина резания, мм

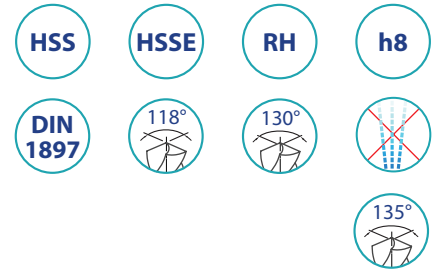
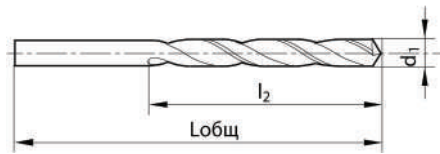

HSS

HSSE

M42



Глубина обработки	3xD	3xD	3xD	3xD	3xD	3xD	3xD	3xD	3xD	3xD	3xD	3xD
Материал	HSS	HSS	HSS	HSS	HSS	HSSE	HSSE	HSSE	HSSE	HSSE	HSSE	M42
Покрытие	BR	V	Nit	TIN	TiAIN	BR	BR	TIN	V	TIN	TiAIN	BR
Угол при вершине	118°	118°	130°	118°	118°	130°	118°	118°	118°	130°	130°	135°
Тип						Va	uni	uni	Va			uni
Группы обрабатываемых материалов Основное применение	P	•	•	•	•	○	•	•	•	•	•	•
	M					•	•	•	•	•	•	○
	N	•	•	•	•	○	○	•	○	○	○	•
	K	•	•	•	•	•	•	•	•	•	•	•
	S						○			•	•	•
H									○	○	○	

d1	Лобц	l2	Артикулы															
			STD1116	STD1110	STD2110	STD7110	STD7117	STD7210	STD3210	STD2210	STD1210	STD7216	STD7215	STD3510				
10,25	80	43		•														
10,3				•														
10,4				•														
10,5				•	•					•		•		•		•		•
10,6												•						
10,7	95	47		•														
10,72																		
10,75				•														
10,8																		
10,9																		
11				•	•	•												
11,1																		
11,2				•	•													
11,3																		
11,4																		
11,5			•	•														
11,7																		
11,8																		
11,9																		
12	102	51	•	•	•	•	•	•	•	•	•	•	•	•	•	•		
12,05																		
12,1																		
12,2					•	•												
12,25																		
12,3																		
12,4																		
12,5					•	•	•	•	•	•	•	•	•	•	•	•	•	•
12,6																		
12,7																		
12,75																		
12,8																		
12,9																		
13					•	•	•	•	•	•	•	•	•	•	•	•	•	•

универсальное применение

Система обозначений	
d1	Диаметр режущей части, мм
Лобц	Общая длина, мм
l2	Максимальная глубина резания, мм

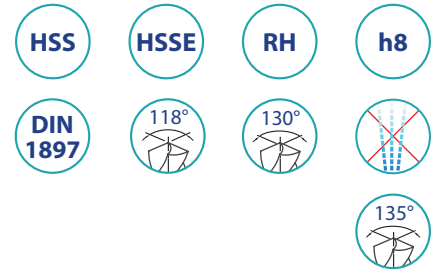
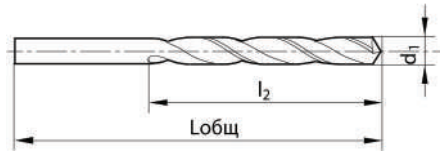

сверла
HSS, HSSE

HSS

HSSE

M42



Глубина обработки	3xD	3xD	3xD	3xD	3xD	3xD	3xD	3xD	3xD	3xD	
Материал	HSS	HSS	HSS	HSS	HSS	HSSE	HSSE	HSSE	HSSE	M42	
Покрытие	BR	V	Nit	TIN	TIAlN	BR	TIN	V	TIN	BR	
Угол при вершине	118°	118°	130°	118°	118°	118°	118°	118°	130°	135°	
Тип						uni	uni	Va		uni	
Группы обрабатываемых материалов Основное применение	P	•	•	•	•	•	•	•	•	•	
	M					•	•	•	•	•	
	N	•	•		•	•	•	•	•	•	
	K	•	•	•	•	•	•	•	•	•	
	S							•	•	•	
	H							•	•		
d1	Лобц	l2	Артикулы								
STD1116 STD1110 STD2110 STD7110 STD7117 STD3210 STD2210 STD1210 STD7216 STD3510											
13,1	102	51		•							
13,2				•							
13,5	107	54		•		•		•	•	•	
13,6				•							
13,75				•					•		
13,8				•		•			•		•
14	111	56	•	•			•	•	•	•	
14,2				•							
14,25				•							
14,3				•							
14,5				•					•	•	•
14,75				•							
14,8				•							
15	115	58		•	•				•	•	
15,1				•							
15,25				•							
15,3				•		•					
15,5				•	•	•			•	•	
15,75		•					•	•			
16				•				•	•		
16,25	119	60		•							
16,27				•							
16,5				•					•	•	
17	123	62		•					•	•	
17,5				•		•			•	•	
18	127	64		•					•	•	
18,2				•							
18,5				•		•			•	•	
18,75				•							
19	131	66		•					•	•	
19,1				•					•	•	
19,5				•		•			•	•	
20				•		•			•	•	

СВЕРЛА

3xD ИЗ БЫСТРОРЕЖУЩЕЙ СТАЛИ HSS И HSSE



STAMO

универсальное применение

Сверла
HSS, HSSE

Система обозначений	
d1	Диаметр режущей части, мм
Лобц	Общая длина, мм
l2	Максимальная глубина резания, мм

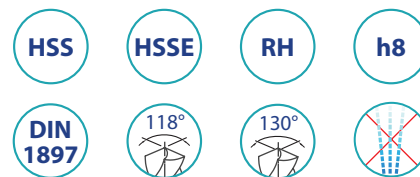
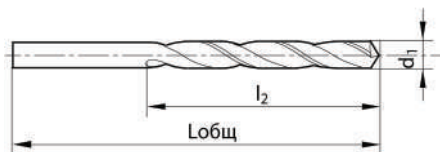

HSS

HSSE



Глубина обработки	3xD	3xD	3xD
Материал	HSS	HSS	HSSE
Покрытие	V	TiN	V
Угол при вершине	118°	118°	118°
Тип			Va
Группы обрабатываемых материалов Основное применение	P	•	•
	M	•	•
	N	•	•
	K	•	•
	S	•	•
	H		
d1	Лобц	l2	
STD1110 STD7110 STD1210			
20,5	136	68	•
21			•
21,5			•
22	141	70	•
22,2			•
22,5	146	72	•
23			•
23,5			•
24			•
24,5	151	75	•
25			•
26			•
26,5	156	78	•
27			•
27,5	162	81	•
28			•
28,75	168	84	•
29			•
30			•
31	174	87	•
32			•
39,5	200	100	•

универсальное применение

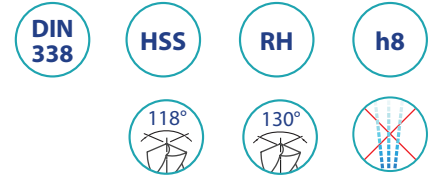
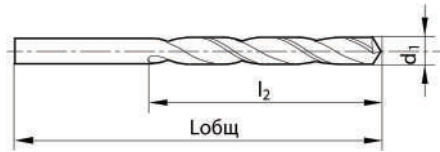

сверла
HSS, HSS-E

Система обозначений	
d1	Диаметр режущей части, мм
Лобц	Общая длина, мм
l2	Максимальная глубина резания, мм



Глубина обработки	5xD	5xD	5xD	5xD	
Материал	HSS	HSS	HSS	HSS	
Покрытие	BR	V	NiP	TiN	
Угол при вершине	118°	118°	130°	118°	
Группы обрабатываемых материалов Основное применение	P	•	•	•	
	M				
	N	•	•	•	
	K	•	•	•	
	S				
H					
d1	Лобц	l2	Артикулы		
STD1126 STD1120 STD2120 STD7120					
0,2	19	2,5		•	
0,22				•	
0,23				•	
0,24				•	
0,25				•	
0,26				•	
0,27				•	
0,28		3		•	
0,29				•	
0,3				•	
0,31				•	
0,32				•	
0,33				•	
0,35			4		•
0,36		•			
0,37		•			
0,38		•			
0,39		•			
0,4		•			
0,41		•			
0,42	20	5		•	
0,43				•	
0,44				•	
0,45				•	
0,46				•	
0,47				•	
0,48				•	
0,49	22	6		•	
0,5				•	
0,51				•	
0,52				•	
0,53				•	

0,54	24	7		•				
0,55				•	•			
0,56				•	•			
0,57				•	•			
0,58				•	•			
0,59				•	•			
0,6				•	•	•		
0,61			26	8		•	•	
0,62						•	•	
0,63						•	•	
0,64						•	•	
0,65						•	•	
0,66						•	•	
0,67						•	•	
0,68		•			•			
0,69		•			•			
0,7	28	9				•	•	
0,71						•	•	•
0,72						•	•	
0,73						•	•	
0,74						•	•	
0,75				•	•			
0,76				•	•			
0,77				•	•			
0,78				•	•			
0,79				•	•			
0,8			30	10		•	•	
0,81						•	•	
0,82						•	•	•
0,83						•	•	
0,84		•			•			
0,85		•			•			
0,86		•			•			
0,87		•			•			
0,88		•			•			
0,89		•			•			
0,9	32	11				•	•	
0,91						•	•	
0,92						•	•	
0,93						•	•	
0,94				•	•			
0,95				•	•			
0,96				•	•			
0,97			34	12		•		
0,98						•	•	
0,99						•	•	



универсальное применение

Сверла
HSS, HSS-E

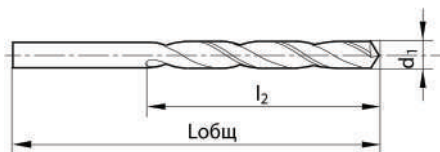

DIN 338

HSS

RH

h8

118°

130°



Система обозначений	
d1	Диаметр режущей части, мм
Лобц	Общая длина, мм
l2	Максимальная глубина резания, мм



Глубина обработки	5xD	5xD	5xD	5xD	5xD	5xD	5xD		
Материал	HSS	HSS	HSS	HSS	HSS	HSS	HSS		
Покрытие	BR	V	Nit	TiN	TiN	TiN	TiAlN		
Угол при вершине	118°	118°	130°	118°	118°	130°	130°		
Группы обрабатываемых материалов Основное применение	P	•	•	•	•	•	•		
	M	•	•	•	•	•	•		
	N	•	•	•	•	•	•		
	K	•	•	•	•	•	•		
	S	•	•	•	•	•	•		
H									
d1	Лобц	l2	Артикулы						
			STD1126	STD1120	STD2120	STD3120	STD7120	STD2125	STD7127
1	34	12	•	•	•	•	•	•	•
1,01			•						
1,02			•				•		
1,03			•						
1,04			•						
1,05									
1,07	36	14	•	•					
1,1			•	•	•	•	•		•
1,11			•	•					
1,12			•						
1,13			•						
1,14			•						
1,15			•					•	
1,16			•						
1,17			•						
1,18			•						
1,19	38	16	•	•	•	•	•		•
1,2			•	•	•	•	•		•
1,21			•						
1,22			•						
1,23	38	16	•						
1,24			•						
1,25			•				•		
1,26			•						
1,27			•						
1,28			•						
1,3	40	18	•	•	•	•	•	•	•
1,31			•	•					
1,35			•	•	•		•		
1,36			•						
1,37			•						
1,4			•	•	•	•	•	•	•
1,41									
1,42			•						



универсальное применение

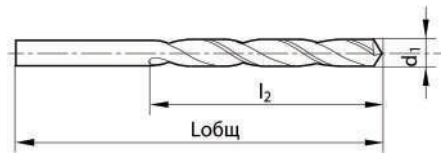

DIN 338

HSS

RH

h8



сверла HSS, HSS-E

Система обозначений	
d1	Диаметр режущей части, мм
Лобц	Общая длина, мм
l2	Максимальная глубина резания, мм



Глубина обработки	5xD	5xD	5xD	5xD	5xD	5xD	5xD		
Материал	HSS	HSS	HSS	HSS	HSS	HSS	HSS		
Покрытие	BR	V	Nit	TiN	TiN	TiN	TiAlN		
Угол при вершине	118°	118°	130°	118°	118°	130°	130°		
Группы обрабатываемых материалов Основное применение	P	•	•	•	•	•	•		
	M								
	N	•	•	•	•	•	•		
	K	•	•	•	•	•	•		
	S								
H									
d1	Лобц	l2	Артикулы						
			STD1126	STD1120	STD2120	STD3120	STD7120	STD2125	STD7127
1,43	40	18		•					
1,44				•					
1,45			•	•	•		•		
1,46				•					
1,48				•					
1,49				•					
1,5		•	•	•	•	•	•	•	
1,51	43	20		•					
1,52				•					
1,55			•	•	•		•		
1,56				•					
1,57				•					
1,58				•					
1,59				•			•		
1,6			•	•	•	•	•		•
1,62				•					
1,65			•	•	•		•		
1,7		•	•	•	•	•	•		
1,72	46	22		•					
1,73				•					
1,74				•					
1,75			•	•			•		
1,76				•					
1,8			•	•	•	•	•	•	•
1,81			•	•					
1,82				•			•		
1,83				•					
1,84				•					
1,85			•	•	•				
1,89				•					
1,9	•	•	•	•	•		•		
1,91	49	24		•					
1,92				•					
1,93				•					

СВЕРЛА

5xD ИЗ БЫСТРОРЕЖУЩЕЙ СТАЛИ HSS



STAMO

универсальное применение

Сверла
HSS, HSS-E

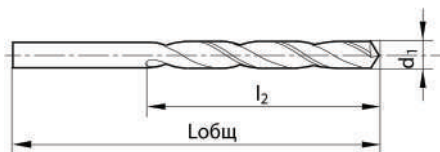

DIN 338

HSS

RH

h8

118°

130°



Система обозначений	
d1	Диаметр режущей части, мм
Лобц	Общая длина, мм
L2	Максимальная глубина резания, мм



Глубина обработки	5xD	5xD	5xD	5xD	5xD	5xD	5xD		
Материал	HSS	HSS	HSS	HSS	HSS	HSS	HSS		
Покрытие	BR	V	Nit	TiN	TiN	TiN	TiAlN		
Угол при вершине	118°	118°	130°	118°	118°	130°	130°		
Группы обрабатываемых материалов Основное применение	P	•	•	•	•	•	•		
	M	•	•	•	•	•	•		
	N	•	•	•	•	•	•		
	K	•	•	•	•	•	•		
	S	•	•	•	•	•	•		
H									
d1	Лобц	L2	Артикулы						
			STD1126	STD1120	STD2120	STD3120	STD7120	STD2125	STD7127
1,95	49	24	•	•	•				
1,98						•			
1,99									
2			•	•	•	•	•	•	•
2,01									
2,02									
2,03									
2,04									
2,05			•	•	•		•		
2,1			•	•	•	•	•		•
2,11									
2,12									
2,15	53	27	•	•	•		•		
2,17									
2,2			•	•	•	•	•	•	•
2,22									
2,25			•	•			•		
2,27									
2,3	53	27	•	•	•	•	•	•	
2,33									
2,35			•	•	•				
2,36									
2,37									
2,38							•		
2,4			•	•	•	•	•	•	•
2,44									
2,45			•	•			•		
2,46									
2,49	57	30			•				
2,5			•	•	•	•	•	•	
2,51									
2,52							•		
2,53							•		
2,55			•	•	•		•		



универсальное применение

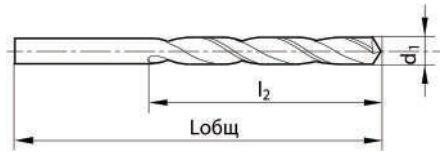

DIN 338

HSS

RH

h8



сверла HSS, HSS-E

Система обозначений	
d1	Диаметр режущей части, мм
Лобц	Общая длина, мм
l2	Максимальная глубина резания, мм



Глубина обработки	5xD	5xD	5xD	5xD	5xD	5xD	5xD		
Материал	HSS	HSS	HSS	HSS	HSS	HSS	HSS		
Покрытие	BR	V	Nit	TiN	TiN	TiN	TiAlN		
Угол при вершине	118°	118°	130°	118°	118°	130°	130°		
Группы обрабатываемых материалов Основное применение	P	•	•	•	•	•	•		
	M								
	N	•	•	•	•	•	•		
	K	•	•	•	•	•	•		
	S								
H									
d1	Лобц	l2	Артикулы						
			STD1126	STD1120	STD2120	STD3120	STD7120	STD2125	STD7127
2,57	57	30		•					
2,6			•	•	•	•	•	•	
2,64			•						
2,65	61	33	•	•			•		
2,7			•	•	•	•	•		•
2,75			•	•	•	•	•		
2,78			•	•		•			
2,8			•	•	•	•			•
2,85			•	•	•	•	•		
2,88			•	•					
2,9			•	•	•	•	•	•	•
2,94			•	•					
2,95			•	•				•	
2,97	•	•	•						
3	•	•	•	•	•	•	•		
3,01	65	36	•	•		•			
3,02			•						
3,05			•	•			•		
3,07	65	36	•	•					
3,1			•	•	•	•	•	•	•
3,15			•	•	•	•	•		
3,16			•	•					
3,17			•	•		•		•	
3,2			•	•	•	•	•	•	•
3,25			•	•	•	•	•		
3,26			•	•	•	•	•		
3,3			•	•	•	•	•	•	•
3,35			•	•	•	•	•	•	
3,4	70	39	•	•	•	•	•	•	•
3,45			•	•	•	•	•	•	•
3,5			•	•	•	•	•	•	•
3,55			•	•	•	•	•	•	•
3,6			•	•	•	•	•	•	•
3,65			•	•	•	•	•	•	•
3,65			•	•	•	•	•	•	•



универсальное применение

Сверла
HSS, HSS-E

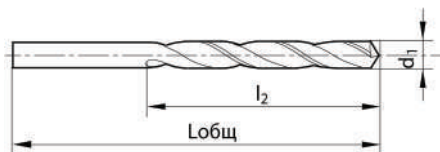

DIN 338

HSS

RH

h8

118°

130°



Система обозначений	
d1	Диаметр режущей части, мм
Лобц	Общая длина, мм
l2	Максимальная глубина резания, мм



Глубина обработки	5xD	5xD	5xD	5xD	5xD	5xD	5xD		
Материал	HSS	HSS	HSS	HSS	HSS	HSS	HSS		
Покрытие	BR	V	Nit	TiN	TiN	TiN	TiAlN		
Угол при вершине	118°	118°	130°	118°	118°	130°	130°		
Группы обрабатываемых материалов Основное применение	P	•	•	•	•	•	•		
	M								
	N	•	•	•	•	•	•		
	K	•	•	•	•	•	•		
	S								
H									
d1	Лобц	l2	Артикулы						
			STD1126	STD1120	STD2120	STD3120	STD7120	STD2125	STD7127
3,67	70	39		•					
3,68				•					
3,7			•	•	•	•	•	•	
3,75			•	•		•			
3,8	75	43	•	•	•	•	•	•	•
3,85				•					
3,9			•	•	•	•	•	•	•
3,93				•					
3,95				•	•		•		
3,97				•			•		
3,99				•					
4				•	•	•	•	•	•
4,03				•					
4,04				•					
4,05		•	•						
4,06		•							
4,09		•		•					
4,1		•	•	•	•	•	•		
4,15	75	43		•			•		
4,2			•	•	•	•	•	•	
4,22				•					
4,25				•	•		•		
4,3	80	47	•	•	•	•	•	•	
4,32				•					
4,35				•					
4,37				•		•			
4,39				•					
4,4				•	•	•	•	•	•
4,45				•					
4,5				•	•	•	•	•	•
4,53				•					
4,55				•					
4,57		•							
4,6		•	•	•	•	•	•		



универсальное применение

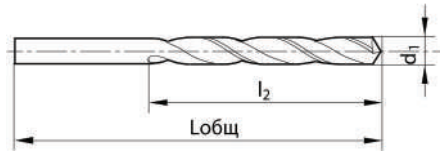

DIN 338

HSS

RH

h8



сверла HSS, HSS-E

Система обозначений	
d1	Диаметр режущей части, мм
Лобц	Общая длина, мм
l2	Максимальная глубина резания, мм



Глубина обработки	5xD	5xD	5xD	5xD	5xD	5xD	5xD		
Материал	HSS	HSS	HSS	HSS	HSS	HSS	HSS		
Покрытие	BR	V	Nit	TiN	TiN	TiN	TiAlN		
Угол при вершине	118°	118°	130°	118°	118°	130°	130°		
Группы обрабатываемых материалов Основное применение	P	•	•	•	•	•	•		
	M								
	N	•	•	•	•	•	•		
	K	•	•	•	•	•	•		
	S								
H									
d1	Лобц	l2	Артикулы						
			STD1126	STD1120	STD2120	STD3120	STD7120	STD2125	STD7127
4,65	80	47	•	•	•	•	•	•	•
4,7			•	•	•	•	•	•	•
4,75			•	•	•	•	•	•	•
4,76	86	52	•	•	•	•	•	•	•
4,78			•	•	•	•	•	•	•
4,8			•	•	•	•	•	•	•
4,83			•	•	•	•	•	•	•
4,85			•	•	•	•	•	•	•
4,9			•	•	•	•	•	•	•
4,92			•	•	•	•	•	•	•
4,95			•	•	•	•	•	•	•
5			•	•	•	•	•	•	•
5,03			•	•	•	•	•	•	•
5,05	•	•	•	•	•	•	•		
5,06	•	•	•	•	•	•	•		
5,1	•	•	•	•	•	•	•		
5,11	•	•	•	•	•	•	•		
5,15	•	•	•	•	•	•	•		
5,16	•	•	•	•	•	•	•		
5,2	86	52	•	•	•	•	•	•	•
5,25			•	•	•	•	•	•	•
5,3			•	•	•	•	•	•	•
5,31	93	57	•	•	•	•	•	•	•
5,35			•	•	•	•	•	•	•
5,4			•	•	•	•	•	•	•
5,41			•	•	•	•	•	•	•
5,42			•	•	•	•	•	•	•
5,45			•	•	•	•	•	•	•
5,5			•	•	•	•	•	•	•
5,53			•	•	•	•	•	•	•
5,55			•	•	•	•	•	•	•
5,56			•	•	•	•	•	•	•
5,6	•	•	•	•	•	•	•		
5,61	•	•	•	•	•	•	•		

СВЕРЛА

5xD ИЗ БЫСТРОРЕЖУЩЕЙ СТАЛИ HSS



STAMO

универсальное применение

Сверла
HSS, HSS-E

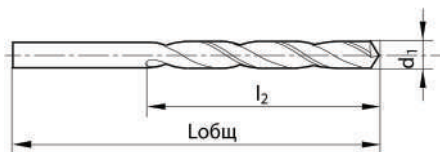

DIN 338

HSS

RH

h8

118°

130°



Система обозначений	
d1	Диаметр режущей части, мм
Лобц	Общая длина, мм
L2	Максимальная глубина резания, мм



Глубина обработки	5xD	5xD	5xD	5xD	5xD	5xD	5xD		
Материал	HSS	HSS	HSS	HSS	HSS	HSS	HSS		
Покрытие	BR	V	Nit	TiN	TiN	TiN	TiAlN		
Угол при вершине	118°	118°	130°	118°	118°	130°	130°		
Группы обрабатываемых материалов Основное применение	P	•	•	•	•	•	•		
	M								
	N	•	•	•	•	•	•		
	K	•	•	•	•	•	•		
	S								
H									
d1	Лобц	L2	Артикулы						
			STD1126	STD1120	STD2120	STD3120	STD7120	STD2125	STD7127
5,62	93	57		•					
5,65				•					
5,7				•	•	•	•	•	•
5,75				•					
5,79				•					
5,8				•	•	•	•	•	•
5,85				•	•	•	•	•	•
5,9				•	•	•	•	•	•
5,95				•	•	•	•	•	•
6		•	•	•	•	•	•		
6,03	101	63		•			•		
6,04				•			•		
6,05				•	•				
6,1				•	•	•	•	•	
6,15				•	•	•	•	•	
6,2				•	•	•	•	•	•
6,25				•	•	•	•	•	
6,3				•	•	•	•	•	•
6,35				•	•	•	•	•	
6,4		•	•	•	•	•	•		
6,45		•	•	•	•	•			
6,5		•	•	•	•	•	•		
6,55		•	•	•	•	•			
6,6		•	•	•	•	•	•		
6,65		•	•	•	•	•			
6,7		•	•	•	•	•	•		
6,75		•	•	•	•	•			
6,8	109	69		•	•	•	•	•	•
6,85				•	•	•	•	•	
6,9				•	•	•	•	•	•
6,95				•	•	•	•	•	
7				•	•	•	•	•	•
7,05				•	•	•	•	•	
7,1				•	•	•	•	•	•



универсальное применение

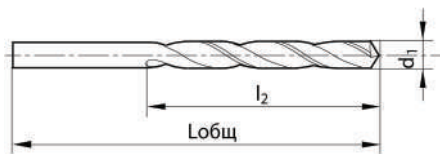

DIN 338

HSS

RH

h8



сверла HSS, HSS-E

Система обозначений	
d1	Диаметр режущей части, мм
Лобц	Общая длина, мм
l2	Максимальная глубина резания, мм



Глубина обработки	5xD	5xD	5xD	5xD	5xD	5xD	5xD				
Материал	HSS	HSS	HSS	HSS	HSS	HSS	HSS				
Покрытие	BR	V	Nit	TiN	TiN	TiN	TiAlN				
Угол при вершине	118°	118°	130°	118°	118°	130°	130°				
Группы обрабатываемых материалов Основное применение	P	•	•	•	•	•	•				
	M										
	N	•	•	•	•	•	•				
	K	•	•	•	•	•	•				
	S										
H											
d1	Лобц	l2	Артикулы								
			STD1126	STD1120	STD2120	STD3120	STD7120	STD2125	STD7127		
7,14	109	69	•	•	•	•			•		
7,2			•	•	•	•	•		•		
7,25			•	•	•	•					
7,3			•	•	•	•	•		•		
7,35			•	•	•	•					
7,4			•	•	•	•	•		•		
7,45			•	•	•	•					
7,5	•	•	•	•			•	•			
7,54	117	75	•	•	•	•			•		
7,6			•	•	•	•	•		•		
7,7			•	•	•	•	•	•	•		
7,75			•	•	•	•					
7,8			•	•	•	•	•	•	•		
7,85			•	•	•	•					
7,9			•	•	•	•	•		•		
7,94	117	75	•	•	•	•					
7,95			•	•	•	•					
8			•	•	•	•	•	•	•		
8,05			•	•	•	•					
8,1			•	•	•	•	•	•	•		
8,2			•	•	•	•					
8,25			•	•	•	•	•	•	•		
8,3	117	75	•	•	•	•					
8,33			•	•	•	•					
8,4			•	•	•	•	•		•		
8,45			•	•	•	•					
8,5			•	•	•	•	•	•	•		
8,55			125	81	•	•	•	•			
8,6					•	•	•	•	•	•	•
8,7	•	•			•	•	•		•		
8,73	•	•			•	•					
8,75	•	•			•	•					
8,8	•	•			•	•	•	•	•		
8,85	•	•			•	•					



универсальное применение

Сверла
HSS, HSS-E

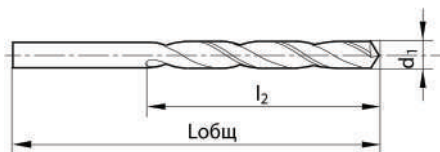

DIN 338

HSS

RH

h8

118°

130°



Система обозначений	
d1	Диаметр режущей части, мм
Лобц	Общая длина, мм
l2	Максимальная глубина резания, мм



Глубина обработки	5xD	5xD	5xD	5xD	5xD	5xD	5xD		
Материал	HSS	HSS	HSS	HSS	HSS	HSS	HSS		
Покрытие	BR	V	Nit	TiN	TiN	TiN	TiAlN		
Угол при вершине	118°	118°	130°	118°	118°	130°	130°		
Группы обрабатываемых материалов Основное применение	P	•	•	•	•	•	•		
	M	•	•	•	•	•	•		
	N	•	•	•	•	•	•		
	K	•	•	•	•	•	•		
	S	•	•	•	•	•	•		
H									
d1	Лобц	l2	Артикулы						
			STD1126	STD1120	STD2120	STD3120	STD7120	STD2125	STD7127
8,9	125	81	•	•	•	•	•	•	•
9			•	•	•	•	•	•	•
9,05			•	•	•	•	•	•	•
9,1			•	•	•	•	•	•	•
9,13			•	•	•	•	•	•	•
9,2			•	•	•	•	•	•	•
9,25			•	•	•	•	•	•	•
9,3			•	•	•	•	•	•	•
9,35			•	•	•	•	•	•	•
9,4			•	•	•	•	•	•	•
9,5	•	•	•	•	•	•	•		
9,52	133	87	•	•	•	•	•	•	•
9,55			•	•	•	•	•	•	•
9,6			•	•	•	•	•	•	•
9,65			•	•	•	•	•	•	•
9,7			•	•	•	•	•	•	•
9,75			•	•	•	•	•	•	•
9,8	133	87	•	•	•	•	•	•	•
9,9			•	•	•	•	•	•	•
9,92			•	•	•	•	•	•	•
9,95			•	•	•	•	•	•	•
10			•	•	•	•	•	•	•
10,05			•	•	•	•	•	•	•
10,08			•	•	•	•	•	•	•
10,1			•	•	•	•	•	•	•
10,2			•	•	•	•	•	•	•
10,25			•	•	•	•	•	•	•
10,3	•	•	•	•	•	•	•		
10,32	•	•	•	•	•	•	•		
10,4	•	•	•	•	•	•	•		
10,5	•	•	•	•	•	•	•		
10,6	•	•	•	•	•	•	•		



универсальное применение

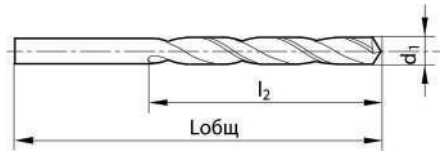

DIN 338

HSS

RH

h8



сверла HSS, HSS-E

Система обозначений	
d1	Диаметр режущей части, мм
Лобц	Общая длина, мм
l2	Максимальная глубина резания, мм



Глубина обработки	5xD	5xD	5xD	5xD	5xD	5xD	5xD			
Материал	HSS	HSS	HSS	HSS	HSS	HSS	HSS			
Покрытие	BR	V	NiTi	TiN	TiN	TiN	TiAlN			
Угол при вершине	118°	118°	130°	118°	118°	130°	130°			
Группы обрабатываемых материалов Основное применение	P	•	•	•	•	•	•			
	M									
	N	•	•	•	•	•	•			
	K	•	•	•	•	•	•			
	S									
H										
d1	Лобц	l2	Артикулы							
			STD1126	STD1120	STD2120	STD3120	STD7120	STD2125	STD7127	
10,7	142	94	•	•		•	•		•	
10,72										
10,75										
10,8					•			•	•	
10,9					•	•	•	•		
11					•	•	•	•	•	•
11,1					•	•	•	•		
11,11					•	•	•	•		
11,2					•	•	•	•		
11,25					•	•	•	•		
11,3					•	•	•	•		
11,4					•	•	•	•		•
11,5					•	•	•	•	•	•
11,51					•	•	•	•		
11,6					•	•	•	•		•
11,7					•	•	•	•	•	
11,75					•	•	•	•		
11,8			•	•	•	•	•	•		
11,9	151	101	•	•	•	•	•			
11,91					•	•	•	•	•	
12					•	•	•	•	•	•
12,05					•	•	•	•		•
12,1					•	•	•	•		
12,2					•	•	•	•	•	
12,25					•	•	•	•		
12,3					•	•	•	•		•
12,4					•	•	•	•		
12,5					•	•	•	•	•	•
12,6					•	•	•	•		
12,7					•	•	•	•		•
12,75					•	•	•	•		
12,8			•	•	•	•	•	•		
12,85			•	•	•	•				
12,9			•	•	•	•	•			

СВЕРЛА

5xD ИЗ БЫСТРОРЕЖУЩЕЙ СТАЛИ HSS



STAMO

универсальное применение

Сверла
HSS, HSS-E

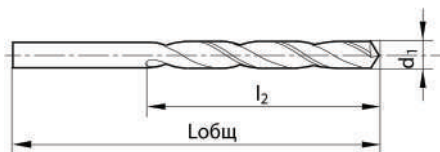

DIN 338

HSS

RH

h8

118°

130°



Система обозначений	
d1	Диаметр режущей части, мм
Лобц	Общая длина, мм
l2	Максимальная глубина резания, мм



Глубина обработки	5xD	5xD	5xD	5xD	5xD	5xD	5xD		
Материал	HSS	HSS	HSS	HSS	HSS	HSS	HSS		
Покрытие	BR	V	NiTi	TiN	TiN	TiN	TiAlN		
Угол при вершине	118°	118°	130°	118°	118°	130°	130°		
Группы обрабатываемых материалов Основное применение	P	•	•	•	•	•	•		
	M	•	•	•	•	•	•		
	N	•	•	•	•	•	•		
	K	•	•	•	•	•	•		
	S	•	•	•	•	•	•		
	H	•	•	•	•	•	•		
d1	Лобц	l2	Артикулы						
			STD1126	STD1120	STD2120	STD3120	STD7120	STD2125	STD7127
13	151	101	•	•	•	•	•	•	•
13,1			•	•	•	•	•	•	•
13,2			•	•	•	•	•	•	•
13,25			•	•	•	•	•	•	•
13,3	160	108	•	•	•	•	•	•	•
13,4			•	•	•	•	•	•	•
13,49			•	•	•	•	•	•	•
13,5			•	•	•	•	•	•	•
13,6			•	•	•	•	•	•	•
13,7			•	•	•	•	•	•	•
13,75			•	•	•	•	•	•	•
13,8			•	•	•	•	•	•	•
13,9			•	•	•	•	•	•	•
14			•	•	•	•	•	•	•
14,1	169	114	•	•	•	•	•	•	•
14,2			•	•	•	•	•	•	•
14,25			•	•	•	•	•	•	•
14,3			•	•	•	•	•	•	•
14,4	169	114	•	•	•	•	•	•	•
14,5			•	•	•	•	•	•	•
14,6			•	•	•	•	•	•	•
14,7			•	•	•	•	•	•	•
14,75			•	•	•	•	•	•	•
14,8			•	•	•	•	•	•	•
14,9	•	•	•	•	•	•	•		
15	178	120	•	•	•	•	•	•	•
15,08			•	•	•	•	•	•	•
15,1			•	•	•	•	•	•	•
15,2			•	•	•	•	•	•	•
15,25			•	•	•	•	•	•	•
15,4			•	•	•	•	•	•	•
15,5			•	•	•	•	•	•	•
15,6			•	•	•	•	•	•	•
15,7	•	•	•	•	•	•	•		



универсальное применение

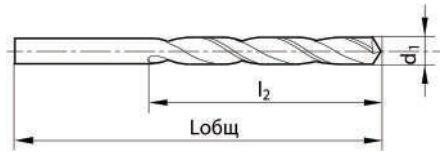

DIN 338

HSS

RH

h8



сверла
HSS, HSS-E

Система обозначений	
d1	Диаметр режущей части, мм
Лобц	Общая длина, мм
l2	Максимальная глубина резания, мм



Глубина обработки	5xD	5xD	5xD	5xD	5xD	5xD		
Материал	HSS	HSS	HSS	HSS	HSS	HSS		
Покрытие	BR	V	Nit	TiN	TiN	TiAlN		
Угол при вершине	118°	118°	130°	118°	118°	130°		
Группы обрабатываемых материалов Основное применение	P	•	•	•	•	•		
	M							
	N	•	•	•	•	•		
	K	•	•	•	•	•		
	S							
	H							
d1	Лобц	l2	Артикулы					
			STD1126	STD1120	STD2120	STD3120	STD7120	STD7127
15,75	178	120	•	•		•		
15,8				•			•	
15,87				•				
16				•	•	•	•	•
16,1	184	125	•	•				
16,2				•				
16,25				•				
16,27				•				
16,5				•			•	
16,7				•				
16,9				•				
17				•			•	
17,25	191	130	•	•				
17,5				•			•	
17,75				•				
17,8				•				
18	198	135	•	•				
18,5				•				
18,75				•				
19				•				
19,25	205	140	•	•				
19,5				•				
20				•				

СВЕРЛА

5xD ИЗ БЫСТРОРЕЖУЩЕЙ СТАЛИ HSSE, M42



STAMO

универсальное применение

сверла
HSS, HSSE

Система обозначений	
d1	Диаметр режущей части, мм
Лобц	Общая длина, мм
l2	Максимальная глубина резания, мм

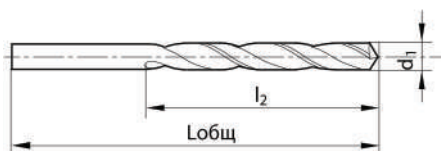

DIN 338

HSSE

RH

h8



Глубина обработки	5xD	5xD	5xD	5xD	5xD	5xD	5xD	5xD	5xD	5xD	5xD	5xD
Материал	HSSE	HSSE	HSSE	HSSE	HSSE	HSSE	HSSE	HSSE	HSSE	HSSE	M42	M42
Покрытие	BR	V	Nit	BR	TIN	TIN	BR	TIN	TiAIN	BR	BR	TiAIN
Угол при вершине	130°	118°	130°	130°	135°	130°	118°	118°	130°	135°	135°	135°
Тип	Va			Ti		UNI				UNI		UNI
Группы обрабатываемых материалов Основное применение	P	•	•	•	•	•	•	•	•	•	•	•
	M	•	•	•	•	•	•	•	•	•	•	•
	N	•	•	•	•	•	•	•	•	•	•	•
	K	•	•	•	•	•	•	•	•	•	•	•
	S	•	•	•	•	•	•	•	•	•	•	•
H												

d1	Лобц	L2	Артикулы													
			STD9220	STD1220	STD5220	STD7220	STD3222	STD2222	STD3220	STD2220	STD7227	STD3520	STD7520			
0,2	19	2,5		•		•										
0,25		3		•		•										
0,3				•		•										
0,35		4			•		•									
0,4	20	5		•		•										
0,43				•		•										
0,45				•		•										
0,5	22	6		•		•										
0,55	24	7		•		•										
0,58				•		•										
0,6				•		•										
0,65	26	8		•		•										
0,68	28	9		•		•										
0,7				•		•										
0,75				•		•										
0,8	30	10		•		•										
0,85				•		•										
0,86				•		•										
0,87	32	11		•		•										
0,9				•		•										
0,95				•		•										
0,98	34	12		•		•										
1				•		•										
1,01				•		•										
1,05	36	14		•		•										
1,1				•		•										
1,15				•		•										
1,17	38	16		•		•										
1,18				•		•										
1,19				•		•										
1,2		•		•												
1,21		•		•												
1,23		•		•												
1,25		•		•												



универсальное применение

Система обозначений	
d1	Диаметр режущей части, мм
Лобц	Общая длина, мм
l2	Максимальная глубина резания, мм

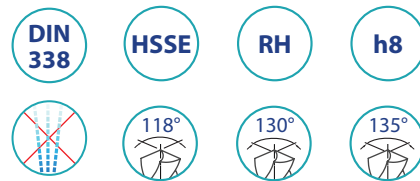
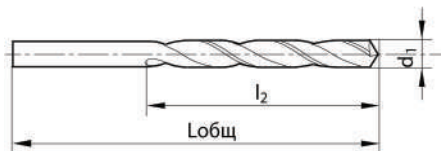

сверла
HSSE, HSSE



Глубина обработки	5xD	5xD	5xD	5xD	5xD	5xD	5xD	5xD	5xD	5xD	5xD	5xD		
Материал	HSSE	HSSE	HSSE	HSSE	HSSE	HSSE	HSSE	HSSE	HSSE	HSSE	M42	M42		
Покрытие	BR	V	Nit	BR	TIN	TIN	BR	TIN	TAIN	BR	TAIN	TAIN		
Угол при вершине	130°	118°	130°	130°	135°	130°	118°	118°	130°	135°	135°	135°		
Тип	Va			Ti			UNI			UNI				
Группы обрабатываемых материалов Основное применение	P	•	•	•	•	•	•	•	•	•	•	•		
	M	•	•	•	•	•	•	•	•	•	•	•		
	N	•	•	•	•	•	•	•	•	•	•	•		
	K	•	•	•	•	•	•	•	•	•	•	•		
	S	•	•	•	•	•	•	•	•	•	•	•		
H	•	•	•	•	•	•	•	•	•	•	•	•		
d1	Лобц	L2	Артикулы											
			STD9220	STD1220	STD5220	STD7220	STD3222	STD2222	STD3220	STD2220	STD7227	STD3520	STD7520	
1,3	38	16	•	•	•	•	•	•	•	•	•	•	•	
1,35	40	18	•	•	•	•	•	•	•	•	•	•	•	
1,37			•	•	•	•	•	•	•	•	•	•	•	
1,4			•	•	•	•	•	•	•	•	•	•	•	
1,45	43	20	•	•	•	•	•	•	•	•	•	•	•	
1,5			•	•	•	•	•	•	•	•	•	•	•	
1,51			•	•	•	•	•	•	•	•	•	•	•	
1,52			•	•	•	•	•	•	•	•	•	•	•	
1,55			•	•	•	•	•	•	•	•	•	•	•	
1,6			•	•	•	•	•	•	•	•	•	•	•	•
1,65			•	•	•	•	•	•	•	•	•	•	•	•
1,7	46	22	•	•	•	•	•	•	•	•	•	•	•	
1,73			•	•	•	•	•	•	•	•	•	•	•	
1,75			•	•	•	•	•	•	•	•	•	•	•	
1,8			•	•	•	•	•	•	•	•	•	•	•	
1,82			•	•	•	•	•	•	•	•	•	•	•	
1,85			•	•	•	•	•	•	•	•	•	•	•	
1,86			•	•	•	•	•	•	•	•	•	•	•	•
1,89			•	•	•	•	•	•	•	•	•	•	•	•
1,9	49	24	•	•	•	•	•	•	•	•	•	•	•	
1,93			•	•	•	•	•	•	•	•	•	•	•	
1,95			•	•	•	•	•	•	•	•	•	•	•	
1,99			•	•	•	•	•	•	•	•	•	•	•	
2			•	•	•	•	•	•	•	•	•	•	•	
2,03			•	•	•	•	•	•	•	•	•	•	•	
2,05			•	•	•	•	•	•	•	•	•	•	•	
2,1	53	27	•	•	•	•	•	•	•	•	•	•	•	
2,15			•	•	•	•	•	•	•	•	•	•	•	
2,2			•	•	•	•	•	•	•	•	•	•	•	
2,25			•	•	•	•	•	•	•	•	•	•	•	
2,27			•	•	•	•	•	•	•	•	•	•	•	
2,3			•	•	•	•	•	•	•	•	•	•	•	
2,35	•	•	•	•	•	•	•	•	•	•	•	•		

СВЕРЛА

5xD ИЗ БЫСТРОРЕЖУЩЕЙ СТАЛИ HSSE, M42



STAMO

универсальное применение

сверла
HSS, HSSE

Система обозначений	
d1	Диаметр режущей части, мм
Лобц	Общая длина, мм
l2	Максимальная глубина резания, мм

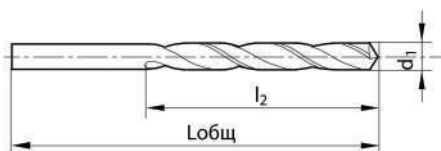

DIN 338

HSSE

RH

h8



Глубина обработки	5xD	5xD	5xD	5xD	5xD	5xD	5xD	5xD	5xD	5xD	5xD	5xD
Материал	HSSE	HSSE	HSSE	HSSE	HSSE	HSSE	HSSE	HSSE	HSSE	HSSE	M42	M42
Покрытие	BR	V	Nit	BR	TIN	TIN	BR	TIN	TiAlN	BR	TiAlN	TiAlN
Угол при вершине	130°	118°	130°	130°	135°	130°	118°	118°	130°	135°	135°	135°
Тип	Va			Ti		UNI				UNI		UNI
Группы обрабатываемых материалов Основное применение	P	•	•	•	•	•	•	•	•	•	•	•
	M	•	•	•	•	•	•	•	•	•	•	•
	N	•	•	•	•	•	•	•	•	•	•	•
	K	•	•	•	•	•	•	•	•	•	•	•
	S	•	•	•	•	•	•	•	•	•	•	•
H												

d1	Лобц	L2	Артикулы											
			STD9220	STD1220	STD5220	STD7220	STD3222	STD2222	STD3220	STD2220	STD7227	STD3520	STD7520	
2,38	57	30				•				•	•		•	
2,4			•	•	•	•	•	•	•	•	•	•	•	
2,45														
2,5			•	•	•	•	•	•	•	•	•	•	•	•
2,55														
2,6			•	•	•	•	•	•	•	•	•	•	•	•
2,65														
2,7	61	33	•	•	•	•	•	•	•	•	•	•	•	
2,75														
2,78														
2,8			•	•	•	•	•	•	•	•	•	•	•	
2,85														
2,9			•	•	•	•	•	•	•	•	•	•	•	
2,95														
3	65	36	•	•	•	•	•	•	•	•	•	•	•	
3,05														
3,1			•	•	•	•	•	•	•	•	•	•	•	
3,15														
3,17														
3,2			•	•	•	•	•	•	•	•	•	•	•	
3,25														
3,3	•	•	•	•	•	•	•	•	•	•	•			
3,35														
3,4	70	39	•	•	•	•	•	•	•	•	•	•		
3,45														
3,5			•	•	•	•	•	•	•	•	•	•		
3,6			•	•	•	•	•	•	•	•	•	•		
3,65														
3,7			•	•	•	•	•	•	•	•	•	•		
3,75														
3,8	75	43	•	•	•	•	•	•	•	•	•	•		
3,9			•	•	•	•	•	•	•	•	•	•		
3,97														

СВЕРЛА

5xD ИЗ БЫСТРОРЕЖУЩЕЙ СТАЛИ HSSE, M42



STAMO

универсальное применение

Система обозначений	
d1	Диаметр режущей части, мм
Лобц	Общая длина, мм
l2	Максимальная глубина резания, мм

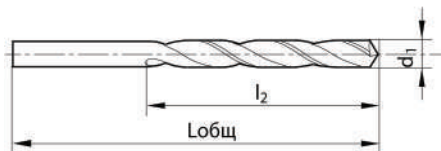

сверла
HSS, HSSE



Глубина обработки	5xD	5xD	5xD	5xD	5xD	5xD	5xD	5xD	5xD	5xD	5xD	5xD			
Материал	HSSE	HSSE	HSSE	HSSE	HSSE	HSSE	HSSE	HSSE	HSSE	HSSE	M42	M42			
Покрытие	BR	V	Nit	BR	TIN	TIN	BR	TIN	TiAlN	BR	TiAlN	TiAlN			
Угол при вершине	130°	118°	130°	130°	135°	130°	118°	118°	130°	135°	135°	135°			
Тип	Va			Ti		UNI				UNI		UNI			
Группы обрабатываемых материалов Основное применение	P	•	•	•	•	•	•	•	•	•	•	•			
	M	•	•	•	•	•	•	•	•	•	•	•			
	N	•	•	•	•	•	•	•	•	•	•	•			
	K	•	•	•	•	•	•	•	•	•	•	•			
	S	•	•	•	•	•	•	•	•	•	•	•			
H	•	•	•	•	•	•	•	•	•	•	•	•			
d1	Лобц	L2	Артикулы												
			STD9220	STD1220	STD5220	STD7220	STD3222	STD2222	STD3220	STD2220	STD7227	STD3520	STD7520		
4	75	43	•	•	•	•	•	•	•	•	•	•	•		
4,05			•	•	•	•	•	•	•	•	•	•	•		
4,1			•	•	•	•	•	•	•	•	•	•	•		
4,15			•	•	•	•	•	•	•	•	•	•	•	•	
4,2			•	•	•	•	•	•	•	•	•	•	•	•	
4,25	•	•	•	•	•	•	•	•	•	•	•	•			
4,3	80	47	•	•	•	•	•	•	•	•	•	•	•		
4,4			•	•	•	•	•	•	•	•	•	•	•		
4,5			•	•	•	•	•	•	•	•	•	•	•		
4,55			•	•	•	•	•	•	•	•	•	•	•		
4,6			•	•	•	•	•	•	•	•	•	•	•		
4,65			•	•	•	•	•	•	•	•	•	•	•		
4,7			•	•	•	•	•	•	•	•	•	•	•	•	
4,75			•	•	•	•	•	•	•	•	•	•	•	•	
4,76			86	52	•	•	•	•	•	•	•	•	•	•	•
4,8					•	•	•	•	•	•	•	•	•	•	•
4,85	•	•			•	•	•	•	•	•	•	•	•		
4,9	•	•			•	•	•	•	•	•	•	•	•		
5	•	•			•	•	•	•	•	•	•	•	•		
5,02	•	•			•	•	•	•	•	•	•	•	•		
5,05	•	•			•	•	•	•	•	•	•	•	•		
5,1	•	•			•	•	•	•	•	•	•	•	•		
5,15	•	•			•	•	•	•	•	•	•	•	•		
5,16	•	•			•	•	•	•	•	•	•	•	•		
5,2	93	57	•	•	•	•	•	•	•	•	•	•	•		
5,25			•	•	•	•	•	•	•	•	•	•	•		
5,3			•	•	•	•	•	•	•	•	•	•	•		
5,4			•	•	•	•	•	•	•	•	•	•	•		
5,4			•	•	•	•	•	•	•	•	•	•	•		
5,5			•	•	•	•	•	•	•	•	•	•	•		
5,55			•	•	•	•	•	•	•	•	•	•	•		
5,56			•	•	•	•	•	•	•	•	•	•	•		
5,6			•	•	•	•	•	•	•	•	•	•	•		
5,7			•	•	•	•	•	•	•	•	•	•	•		

СВЕРЛА

5xD ИЗ БЫСТРОРЕЖУЩЕЙ СТАЛИ HSSE, M42



STAMO

универсальное применение

сверла
HSS, HSSE

Система обозначений	
d1	Диаметр режущей части, мм
Лобц	Общая длина, мм
l2	Максимальная глубина резания, мм

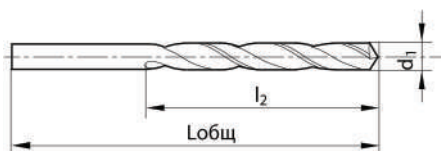

DIN 338

HSSE

RH

h8



Глубина обработки	5xD	5xD	5xD	5xD	5xD	5xD	5xD	5xD	5xD	5xD	5xD	5xD	
Материал	HSSE	HSSE	HSSE	HSSE	HSSE	HSSE	HSSE	HSSE	HSSE	HSSE	M42	M42	
Покрытие	BR	V	Nit	BR	TIN	TIN	BR	TIN	TiAlN	BR	TiAlN	TiAlN	
Угол при вершине	130°	118°	130°	130°	135°	130°	118°	118°	130°	135°	135°	135°	
Тип	Va			Ti		UNI				UNI		UNI	
Группы обрабатываемых материалов Основное применение	P	•	•	•	•	•	•	•	•	•	•	•	
	M	•	•	•	•	•	•	•	•	•	•	•	
	N	•	•	•	•	•	•	•	•	•	•	•	
	K	•	•	•	•	•	•	•	•	•	•	•	
	S	•	•	•	•	•	•	•	•	•	•	•	
H													
d1	Лобц	L2	Артикулы										
			STD9220	STD1220	STD5220	STD7220	STD3222	STD2222	STD3220	STD2220	STD7227	STD3520	STD7520
5,75	93	57	•	•	•	•	•	•	•	•	•	•	•
5,8			•	•	•	•	•	•	•	•	•	•	•
5,85			•	•	•	•	•	•	•	•	•	•	•
5,9			•	•	•	•	•	•	•	•	•	•	•
5,95			•	•	•	•	•	•	•	•	•	•	•
6	101	63	•	•	•	•	•	•	•	•	•	•	•
6,05			•	•	•	•	•	•	•	•	•	•	•
6,1			•	•	•	•	•	•	•	•	•	•	•
6,15			•	•	•	•	•	•	•	•	•	•	•
6,2			•	•	•	•	•	•	•	•	•	•	•
6,3			•	•	•	•	•	•	•	•	•	•	•
6,35			•	•	•	•	•	•	•	•	•	•	•
6,4			•	•	•	•	•	•	•	•	•	•	•
6,5			•	•	•	•	•	•	•	•	•	•	•
6,6			•	•	•	•	•	•	•	•	•	•	•
6,7	•	•	•	•	•	•	•	•	•	•	•		
6,75	109	69	•	•	•	•	•	•	•	•	•	•	•
6,8			•	•	•	•	•	•	•	•	•	•	•
6,9			•	•	•	•	•	•	•	•	•	•	•
7			•	•	•	•	•	•	•	•	•	•	•
7,1			•	•	•	•	•	•	•	•	•	•	•
7,14			•	•	•	•	•	•	•	•	•	•	•
7,2			•	•	•	•	•	•	•	•	•	•	•
7,3			•	•	•	•	•	•	•	•	•	•	•
7,4			•	•	•	•	•	•	•	•	•	•	•
7,5			•	•	•	•	•	•	•	•	•	•	•
7,54	117	75	•	•	•	•	•	•	•	•	•	•	•
7,6			•	•	•	•	•	•	•	•	•	•	•
7,7			•	•	•	•	•	•	•	•	•	•	•
7,8			•	•	•	•	•	•	•	•	•	•	•
7,9			•	•	•	•	•	•	•	•	•	•	•
7,94			•	•	•	•	•	•	•	•	•	•	•
8			•	•	•	•	•	•	•	•	•	•	•



универсальное применение

Система обозначений	
d1	Диаметр режущей части, мм
Лобц	Общая длина, мм
l2	Максимальная глубина резания, мм

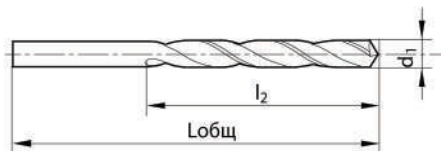

сверла
HSSE, HSSE



Глубина обработки	5xD	5xD	5xD	5xD	5xD	5xD	5xD	5xD	5xD	5xD	5xD	5xD	
Материал	HSSE	HSSE	HSSE	HSSE	HSSE	HSSE	HSSE	HSSE	HSSE	HSSE	M42	M42	
Покрытие	BR	V	Nit	BR	TIN	TIN	BR	TIN	TiAlN	BR	TiAlN	TiAlN	
Угол при вершине	130°	118°	130°	130°	135°	130°	118°	118°	130°	135°	135°	135°	
Тип	Va			Ti			UNI				UNI		
Группы обрабатываемых материалов Основное применение	P	•	•	•	•	•	•	•	•	•	•	•	
	M	•	•	•	•	•	•	•	•	•	•	•	
	N	•	•	•	•	•	•	•	•	•	•	•	
	K	•	•	•	•	•	•	•	•	•	•	•	
	S	•	•	•	•	•	•	•	•	•	•	•	
H													
d1	Лобц	L2	Артикулы										
			STD9220	STD1220	STD5220	STD7220	STD3222	STD2222	STD3220	STD2220	STD7227	STD3520	STD7520
8,05								•					
8,1	117	75	•	•	•	•	•	•	•	•	•	•	•
8,2			•	•	•	•	•	•	•	•	•	•	•
8,3			•	•	•	•	•	•	•	•	•	•	•
8,4			•	•	•	•	•	•	•	•	•	•	•
8,5			•	•	•	•	•	•	•	•	•	•	•
8,6	125	81	•	•	•	•	•	•	•	•	•	•	•
8,7			•	•	•	•	•	•	•	•	•	•	•
8,73			•	•	•	•	•	•	•	•	•	•	•
8,75			•	•	•	•	•	•	•	•	•	•	•
8,8			•	•	•	•	•	•	•	•	•	•	•
8,9			•	•	•	•	•	•	•	•	•	•	•
9			•	•	•	•	•	•	•	•	•	•	•
9,1			•	•	•	•	•	•	•	•	•	•	•
9,2			•	•	•	•	•	•	•	•	•	•	•
9,25			•	•	•	•	•	•	•	•	•	•	•
9,3	•	•	•	•	•	•	•	•	•	•	•		
9,4	•	•	•	•	•	•	•	•	•	•	•		
9,5	•	•	•	•	•	•	•	•	•	•	•		
9,52	133	87	•	•	•	•	•	•	•	•	•	•	
9,6			•	•	•	•	•	•	•	•	•	•	•
9,65			•	•	•	•	•	•	•	•	•	•	•
9,7			•	•	•	•	•	•	•	•	•	•	•
9,8			•	•	•	•	•	•	•	•	•	•	•
9,8			•	•	•	•	•	•	•	•	•	•	•
9,9			•	•	•	•	•	•	•	•	•	•	•
9,92			•	•	•	•	•	•	•	•	•	•	•
10			•	•	•	•	•	•	•	•	•	•	•
10,05			•	•	•	•	•	•	•	•	•	•	•
10,1	•	•	•	•	•	•	•	•	•	•	•		
10,2	•	•	•	•	•	•	•	•	•	•	•		
10,25	•	•	•	•	•	•	•	•	•	•	•		
10,3	•	•	•	•	•	•	•	•	•	•	•		
10,4	•	•	•	•	•	•	•	•	•	•	•		

СВЕРЛА

5xD ИЗ БЫСТРОРЕЖУЩЕЙ СТАЛИ HSSE, M42



STAMO

универсальное применение

Сверла
HSS, HSSE

Система обозначений	
d1	Диаметр режущей части, мм
Лобц	Общая длина, мм
l2	Максимальная глубина резания, мм

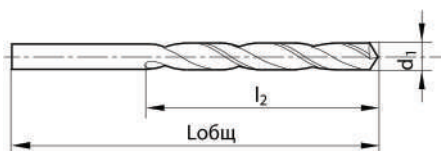

DIN 338

HSSE

RH

h8



Глубина обработки	5xD	5xD	5xD	5xD	5xD	5xD	5xD	5xD	5xD	5xD	5xD
Материал	HSSE	HSSE	HSSE	HSSE	HSSE	HSSE	HSSE	HSSE	HSSE	M42	M42
Покрытие	BR	V	Nit	BR	TIN	TIN	BR	TIN	TiAlN	BR	TiAlN
Угол при вершине	130°	118°	130°	130°	135°	130°	118°	118°	130°	135°	135°
Тип	Va			Ti		UNI				UNI	
Группы обрабатываемых материалов Основное применение	P	•	•	•	•	•	•	•	•	•	•
	M	•	•	•	•	•	•	•	•	•	•
	N	•	•	•	•	•	•	•	•	•	•
	K	•	•	•	•	•	•	•	•	•	•
	S	•	•	•	•	•	•	•	•	•	•
H											

d1	Лобц	L2	Артикулы											
			STD9220	STD1220	STD5220	STD7220	STD3222	STD2222	STD3220	STD2220	STD7227	STD3520	STD7520	
10,5	133	87	•	•	•	•	•	•	•	•	•	•	•	
10,6			•	•	•	•	•	•	•	•	•	•	•	
10,7			•	•	•	•	•	•	•	•	•	•	•	
10,72			•	•	•	•	•	•	•	•	•	•	•	
10,8			•	•	•	•	•	•	•	•	•	•	•	
10,9			•	•	•	•	•	•	•	•	•	•	•	
11			•	•	•	•	•	•	•	•	•	•	•	
11,1			•	•	•	•	•	•	•	•	•	•	•	
11,11			•	•	•	•	•	•	•	•	•	•	•	
11,2			•	•	•	•	•	•	•	•	•	•	•	
11,25	142	94	•	•	•	•	•	•	•	•	•	•		
11,3			•	•	•	•	•	•	•	•	•	•		
11,4			•	•	•	•	•	•	•	•	•	•		
11,5			•	•	•	•	•	•	•	•	•	•		
11,6			•	•	•	•	•	•	•	•	•	•		
11,7			•	•	•	•	•	•	•	•	•	•		
11,75			•	•	•	•	•	•	•	•	•	•		
11,8			•	•	•	•	•	•	•	•	•	•		
11,9			151	101	•	•	•	•	•	•	•	•	•	•
11,91					•	•	•	•	•	•	•	•	•	•
12	•	•			•	•	•	•	•	•	•	•		
12,1	•	•			•	•	•	•	•	•	•	•		
12,2	•	•			•	•	•	•	•	•	•	•		
12,3	•	•			•	•	•	•	•	•	•	•		
12,4	•	•			•	•	•	•	•	•	•	•		
12,5	•	•			•	•	•	•	•	•	•	•		
12,6	•	•			•	•	•	•	•	•	•	•		
12,7	•	•			•	•	•	•	•	•	•	•		
12,8	•	•			•	•	•	•	•	•	•	•		
12,9	•	•			•	•	•	•	•	•	•	•		
13	•	•			•	•	•	•	•	•	•	•		
13,2	•	•			•	•	•	•	•	•	•	•		

СВЕРЛА

5xD ИЗ БЫСТРОРЕЖУЩЕЙ СТАЛИ HSSE, M42



STAMO

универсальное применение

Система обозначений	
d1	Диаметр режущей части, мм
Лобщ	Общая длина, мм
l2	Максимальная глубина резания, мм

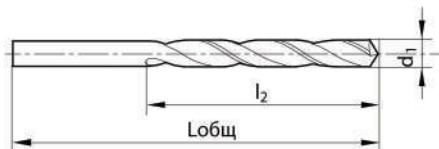

DIN 338

HSSE

RH

h8



сверла HSSE



Глубина обработки	5xD	5xD	5xD	5xD	5xD	5xD		
Материал	HSSE	HSSE	HSSE	HSSE	M42	M42		
Покрытие	V	BR	BR	TIN	BR	TiAlN		
Угол при вершине	118°	130°	118°	118°	135°	135°		
Тип		Ti	UNI		UNI	UNI		
Группы обрабатываемых материалов Основное применение	P	•	○	•	•	•		
	M	○	•	•	•	•		
	N	○	•	•	•	•		
	K	•	•	•	•	○	○	
	S	•	•	•	•	•	•	
H								
d1	Лобщ	L2						
			STD1220	STD7220	STD3220	STD2220	STD3520	STD7520
13,3	160	108	•					
13,4			•					
13,5			•	•	•	•		
13,6			•					
13,7			•					
13,8			•					
13,9						•		
14			•	•	•	•	•	
14,2	169	114	•					
14,4			•					
14,5			•	•				
15			•	•				•
15,25	178	120	•					
15,5			•	•				
15,87			•					
16			•	•				•
16,5	184	125	•	•				
17			•	•				
17,5	191	130	•	•				
19	198	135	•					
20	205	140	•					

СВЕРЛА

10xD ИЗ БЫСТРОРЕЖУЩЕЙ СТАЛИ HSS, HSSE



универсальное применение

сверла
HSS, HSSE

Система обозначений	
d1	Диаметр режущей части, мм
Лобц	Общая длина, мм
l2	Длина рабочей части, мм

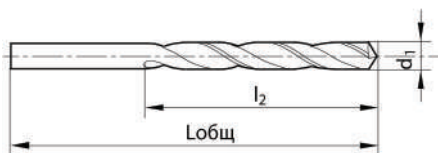

Глубина обработки	10xD	10xD	10xD	10xD	10xD	10xD	10xD	10xD	10xD	10xD	10xD		
Материал	HSS	HSS	HSS	HSS	HSS	HSS	HSSE	HSSE	HSSE	HSSE	HSSE		
Покрытие	BR	V	Nit	TiN	TiN	TiAlN	BR	BR	TiN	V	Nit		
Угол при вершине	118°	118°	130°	118°	130°	130°	118°	118°	118°	118°	130°		
Тип								UNI	UNI				
Группы обрабатываемых материалов Основное применение	P	•	•	•	•	•	•	•	•	•	•		
	M						•	•	•	•	•		
	N	•	•	•	•	•	•	•	•	•	•		
	K	•	•	•	•	•	•	•	•	•	•		
	S									•			
	H												
d1	Лобц	l2	Артикулы										
			STD1146	STD1140	STD6140	STD3140	STD2140	STD7140	STD1246	STD3240	STD2240	STD1240	STD3247
0,40	30,0	10,0		•									
0,50	32,0	12,0		•		•						•	
0,60	35,0	15,0		•								•	
0,65	38,0	18,0		•									
0,70	42,0	21,0		•			•					•	
0,75				•									
0,80	46,0	25,0		•			•					•	
0,85				•									
0,90			•	•	•				•			•	
0,91	51,0	29,0		•									
0,95				•									
1,00	56,0	33,0	•	•	•	•	•	•	•	•	•	•	•
1,10			•	•	•	•	•	•	•	•	•	•	•
1,15	60,0	37,0		•									
1,20			•	•	•	•	•	•	•	•	•	•	•
1,25	65,0	41,0		•									•
1,30			•	•	•	•	•	•	•	•	•	•	•
1,35				•									
1,40			•	•	•	•	•	•	•	•	•	•	•
1,50	70,0	45,0	•	•	•	•	•	•	•	•	•	•	•
1,55				•									
1,60			•	•	•	•	•	•	•	•	•	•	•
1,70			•	•	•	•	•	•	•	•	•	•	•
1,75				•									
1,80			•	•	•	•	•	•	•	•	•	•	•
1,90			•	•	•	•	•	•	•	•	•	•	•
1,95				•									
2,00			•	•	•	•	•	•	•	•	•	•	•
2,05	85,0	56,0		•								•	•
2,10			•	•	•	•	•	•	•	•	•	•	•

универсальное применение

Система обозначений	
d1	Диаметр режущей части, мм
Лобц	Общая длина, мм
l2	Длина рабочей части, мм

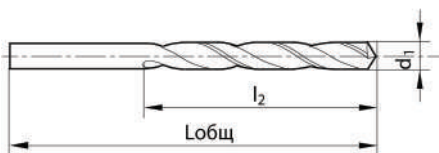

сверла
HSS, HSSE



Глубина обработки	10xD	10xD	10xD	10xD	10xD	10xD	10xD	10xD	10xD	10xD	10xD			
Материал	HSS	HSS	HSS	HSS	HSS	HSS	HSSE	HSSE	HSSE	HSSE	HSSE			
Покрытие	BR	V	Nit	TiN	TiN	TiAIN	BR	BR	TiN	V	Nit			
Угол при вершине	118°	118°	130°	118°	130°	130°	118°	118°	118°	118°	130°			
Тип								UNI	UNI					
Группы обрабатываемых материалов Основное применение	P	•	•	•	•	•	•	•	•	•	•			
	M						•	•	•	•	•			
	N	•	•	•	•	•	•	•	•	•	•			
	K	•	•	•	•	•	•	•	•	•	•			
	S									•				
	H													
d1	Лобц	l2	Артикулы											
			STD1146	STD1140	STD6140	STD3140	STD2140	STD7140	STD1246	STD3240	STD2240	STD1240	STD3247	
2,20	90,0	59,0	•	•	•	•	•	•	•	•	•	•	•	
2,25			•	•										
2,30			•	•	•			•	•	•	•		•	
2,35			•	•										
2,40	95,0	62,0	•	•	•	•	•	•	•	•	•	•	•	
2,44													•	
2,45			•	•										
2,50			•	•	•	•	•	•	•	•	•	•	•	•
2,55			•	•										
2,60			•	•	•	•	•	•	•	•	•	•	•	•
2,65			•	•	•									
2,70	100,0	66,0	•	•	•	•	•	•	•	•	•	•	•	
2,75			•	•										
2,80			•	•	•	•	•	•	•	•	•	•	•	•
2,85			•	•	•									
2,90			•	•	•	•	•	•	•	•	•	•	•	•
2,95			•	•	•									
3,00			•	•	•	•	•	•	•	•	•	•	•	•
3,05	106,0	69,0	•	•	•	•	•	•	•	•	•	•	•	
3,10			•	•	•	•	•	•	•	•	•	•	•	
3,15			•	•										
3,17			•	•	•									
3,20			•	•	•	•	•	•	•	•	•	•	•	•
3,25			•	•	•									
3,30			•	•	•	•	•	•	•	•	•	•	•	•
3,35	•	•	•											
3,40	112,0	73,0	•	•	•	•	•	•	•	•	•	•	•	
3,45			•	•	•	•	•	•	•	•	•	•	•	
3,50			•	•	•	•	•	•	•	•	•	•	•	
3,55			•	•	•									
3,55			•	•	•									
3,55			•	•	•									

СВЕРЛА

10xD ИЗ БЫСТРОРЕЖУЩЕЙ СТАЛИ HSS, HSSE



STAMO

универсальное применение

сверла
HSS, HSSE

Система обозначений	
d1	Диаметр режущей части, мм
Лобц	Общая длина, мм
l2	Длина рабочей части, мм

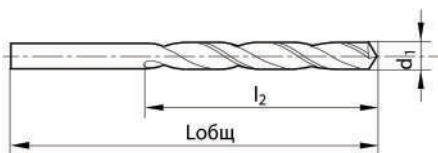

Глубина обработки	10xD	10xD	10xD	10xD	10xD	10xD	10xD	10xD	10xD	10xD	10xD	10xD		
Материал	HSS	HSS	HSS	HSS	HSS	HSS	HSSE	HSSE	HSSE	HSSE	HSSE	HSSE		
Покрытие	BR	V	Nit	TiN	TiN	TiAlN	BR	BR	TiN	V	Nit	Nit		
Угол при вершине	118°	118°	130°	118°	130°	130°	118°	118°	118°	118°	118°	130°		
Тип								UNI	UNI					
Группы обрабатываемых материалов Основное применение	P	•	•	•	•	•	•	•	•	•	•	•		
	M	•	•	•	•	•	•	•	•	•	•	•		
	N	o	o	•	o	•	•	•	•	•	•	•		
	K	•	•	•	•	•	•	•	•	•	•	•		
	S										o			
	H													
d1	Лобц	l2	Артикулы											
			STD1146	STD1140	STD6140	STD3140	STD2140	STD7140	STD1246	STD3240	STD2240	STD1240	STD3247	
3,60	112,0	73,0	•	•	•		•	•	•	•	•		•	
3,65			•	•										
3,70			•	•	•		•	•	•	•	•		•	
3,75			•	•	•									
3,80	119,0	78,0	•	•	•	•	•	•	•	•	•	•	•	
3,85			•	•										
3,90			•	•	•		•	•	•	•	•	•	•	
3,95			•	•	•									
4,00			•	•	•	•	•	•	•	•	•	•	•	
4,04			•	•	•									
4,05			•	•	•									•
4,10			•	•	•	•	•	•	•	•	•	•	•	•
4,15			•	•	•									
4,20			•	•	•	•	•	•	•	•	•	•	•	•
4,25	•	•	•											
4,30	126,0	82,0	•	•	•	•	•	•	•	•	•	•	•	
4,40			•	•	•	•	•	•	•	•	•	•	•	
4,45			•	•	•									
4,50			•	•	•	•	•	•	•	•	•	•	•	
4,55			•	•	•									
4,60			•	•	•	•	•	•	•	•	•	•	•	•
4,65			•	•	•									
4,70			•	•	•	•	•	•	•	•	•	•	•	•
4,75			•	•	•									
4,76			•	•	•									•
4,80	132,0	87,0	•	•	•	•	•	•	•	•	•	•	•	
4,85			•	•	•									
4,90			•	•	•	•	•	•	•	•	•	•	•	•
4,95			•	•	•									
4,95			•	•	•									
5,00			•	•	•	•	•	•	•	•	•	•	•	•

универсальное применение

Система обозначений	
d1	Диаметр режущей части, мм
Лобц	Общая длина, мм
l2	Длина рабочей части, мм

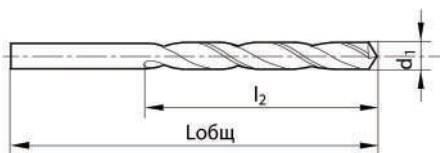

сверла
HSS, HSSE



Глубина обработки	10xD	10xD	10xD	10xD	10xD	10xD	10xD	10xD	10xD	10xD	10xD			
Материал	HSS	HSS	HSS	HSS	HSS	HSS	HSSE	HSSE	HSSE	HSSE	HSSE			
Покрытие	BR	V	Nit	TiN	TiN	TiAlN	BR	BR	TiN	V	Nit			
Угол при вершине	118°	118°	130°	118°	130°	130°	118°	118°	118°	118°	130°			
Тип								UNI	UNI					
Группы обрабатываемых материалов Основное применение	P	•	•	•	•	•	•	•	•	•	•			
	M						•	•	•	o	•			
	N	o	o	•	o	•	•	•	•	•	•			
	K	•	•	•	•	•	•	•	•	•	•			
	S									o				
H														
d1	Лобц	l2	Артикулы											
			STD1146	STD1140	STD6140	STD3140	STD2140	STD7140	STD1246	STD3240	STD2240	STD1240	STD3247	
5,05	132,0	87,0		•										
5,10			•				•	•						
5,15			•											
5,20			•	•	•	•	•	•	•	•	•	•	•	
5,25			•											
5,30				•							•	•		
5,35				•										
5,40	139,0	91,0	•	•	•	•	•	•	•	•	•	•	•	
5,45			•	•	•	•	•	•	•	•	•	•	•	
5,50			•	•	•	•	•	•	•	•	•	•	•	
5,60			•	•	•	•	•	•	•	•	•	•	•	
5,65			•											
5,70			•	•	•	•	•	•	•	•	•	•	•	•
5,75			•											
5,80			•	•	•	•	•	•	•	•	•	•	•	•
5,90			•	•	•	•	•	•	•	•	•	•	•	•
5,95			•											
6,00				•	•	•	•	•	•	•	•	•		
6,10	148,0	97,0	•	•	•	•	•	•	•	•	•	•	•	
6,15														
6,20			•	•	•	•	•	•	•	•	•	•	•	
6,25			•	•	•	•	•	•	•	•	•	•	•	
6,30			•	•	•	•	•	•	•	•	•	•	•	
6,35			•											
6,40			•	•	•	•	•	•	•	•	•	•	•	•
6,50			•	•	•	•	•	•	•	•	•	•	•	•
6,60			•	•	•	•	•	•	•	•	•	•	•	•
6,70			•	•	•	•	•	•	•	•	•	•	•	•

СВЕРЛА

10xD ИЗ БЫСТРОРЕЖУЩЕЙ СТАЛИ HSS, HSSE



универсальное применение

Система обозначений

d1	Диаметр режущей части, мм
Лобц	Общая длина, мм
l2	Длина рабочей части, мм

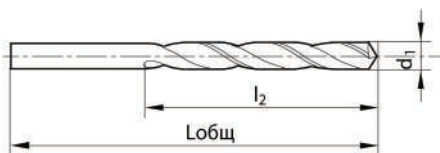

Глубина обработки	10xD	10xD	10xD	10xD	10xD	10xD	10xD	10xD	10xD	10xD	10xD
Материал	HSS	HSS	HSS	HSS	HSS	HSS	HSSE	HSSE	HSSE	HSSE	HSSE
Покрытие	BR	V	Nit	TiN	TiN	TiAlN	BR	BR	TiN	V	Nit
Угол при вершине	118°	118°	130°	118°	130°	130°	118°	118°	118°	118°	130°
Тип								UNI	UNI		
Группы обрабатываемых материалов Основное применение	P	•	•	•	•	•	•	•	•	•	•
	M						•	•	•	•	•
	N	•	•	•	•	•	•	•	•	•	•
	K	•	•	•	•	•	•	•	•	•	•
	S									•	
	H										

d1	Лобц	l2	Артикулы										
			STD1146	STD1140	STD6140	STD3140	STD2140	STD7140	STD1246	STD3240	STD2240	STD1240	STD3247
6,75	156,0	102,0		•									
6,80			•										
6,90			•										
7,00			•										
7,10			•										
7,20			•										
7,25			•										
7,30			•										
7,40			•										
7,50			•										
7,60	165,0	109,0		•									
7,70			•										
7,75			•										
7,80			•										
7,90			•										
7,94			•										
8,00			•										
8,10			•										
8,20			•										
8,25			•										
8,30	•												
8,40	•												
8,50	•												
8,60	175,0	115,0		•									
8,70			•										
8,80			•										
8,90			•										
9,00			•										
9,10			•										
9,20			•										
9,30			•										
9,40			•										
9,50			•										

СВЕРЛА

10xD ИЗ БЫСТРОРЕЖУЩЕЙ СТАЛИ HSS, HSSE



STAMO

универсальное применение

Система обозначений	
d1	Диаметр режущей части, мм
Лобц	Общая длина, мм
l2	Длина рабочей части, мм

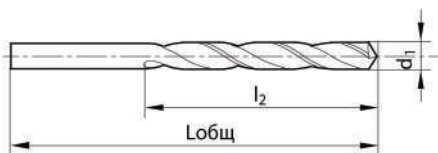

сверла
HSS, HSSE



Глубина обработки	10xD	10xD	10xD	10xD	10xD	10xD	10xD	10xD	10xD	10xD	10xD
Материал	HSS	HSS	HSS	HSS	HSS	HSS	HSSE	HSSE	HSSE	HSSE	HSSE
Покрытие	BR	V	Nit	TiN	TiN	TiAlN	BR	BR	TiN	V	Nit
Угол при вершине	118°	118°	130°	118°	130°	130°	118°	118°	118°	118°	130°
Тип								UNI	UNI		
Группы обрабатываемых материалов Основное применение	P	•	•	•	•	•	•	•	•	•	•
	M						•	•	•	o	•
	N	o	o	•	o	•	•	•	•	•	•
	K	•	•	•	•	•	•	•	•	•	•
	S									o	
	H										

d1	Лобц	l2	Артикулы											
			STD1146	STD1140	STD6140	STD3140	STD2140	STD7140	STD1246	STD3240	STD2240	STD1240	STD3247	
9,60	184,0	121,0	•	•	•				•	•	•	•	•	
9,70			•	•	•				•	•	•	•	•	
9,75				•										
9,80			•	•	•	•	•	•	•	•	•			•
9,90			•	•	•	•			•	•	•	•	•	•
9,92				•										
10,00			•	•	•		•	•	•	•	•	•	•	•
10,10			•	•					•	•	•	•	•	•
10,20			•	•		•			•	•	•	•		•
10,25				•										
10,30			•		•					•	•	•		
10,40			•	•						•	•	•		
10,50			•	•	•					•	•	•	•	•
10,60			•	•						•				
10,70	•	•						•				•		
10,72		•												
10,75		•												
10,80	•		•	•				•			•	•		
10,90	•	•						•			•	•		
11,00	•	•	•	•	•	•	•	•	•	•	•	•		
11,10								•						
11,20	•	•	•					•			•			
11,25		•	•											
11,30	•							•						
11,40	•							•						
11,50	•	•	•	•	•	•	•	•	•	•		•		
11,60	•	•						•						
11,70	•	•						•						
11,75		•												
11,80	•	•	•					•				•		
11,91												•		
11,90	•							•				•		

СВЕРЛА

10xD ИЗ БЫСТРОРЕЖУЩЕЙ СТАЛИ HSS, HSSE



STAMO

универсальное применение

сверла
HSS, HSSE

Система обозначений	
d1	Диаметр режущей части, мм
Лобц	Общая длина, мм
l2	Длина рабочей части, мм

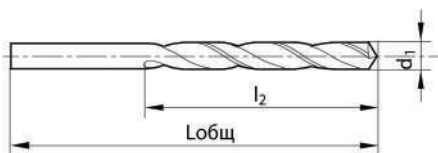

Глубина обработки	10xD	10xD	10xD	10xD	10xD	10xD	10xD	10xD	10xD	10xD	10xD			
Материал	HSS	HSS	HSS	HSS	HSS	HSS	HSSE	HSSE	HSSE	HSSE	HSSE			
Покрытие	BR	V	Nit	TiN	TiN	TiAlN	BR	BR	TiN	V	Nit			
Угол при вершине	118°	118°	130°	118°	130°	130°	118°	118°	118°	118°	130°			
Тип								UNI	UNI					
Группы обрабатываемых материалов Основное применение	P	•	•	•	•	•	•	•	•	•	•			
	M						•	•	•	•	•			
	N	•	•	•	•	•	•	•	•	•	•			
	K	•	•	•	•	•	•	•	•	•	•			
	S									•				
H														
d1	Лобц	l2	Артикулы											
			STD1146	STD1140	STD6140	STD3140	STD2140	STD7140	STD1246	STD3240	STD2240	STD1240	STD3247	
12,00	205,0	134,0	•	•	•	•	•	•	•	•	•	•	•	
12,10			•	•										
12,20			•	•	•									
12,30			•	•										
12,40			•											
12,50			•	•	•	•					•	•	•	•
12,60			•	•							•			
12,70			•	•				•	•	•			•	
12,80			•								•			
12,90			•	•	•						•			
13,00			•	•	•	•					•	•		•
13,10			•								•			
13,20	•	•							•					
13,30	•								•					
13,40	•								•					
13,49		•												
13,50	•	•							•					
13,60	•					•			•					
13,70	•								•					
13,80	•								•					
13,90	•								•					
14,00	•	•	•	•	•	•	•	•	•	•				
14,20		•												
14,25	•	•												
14,50	•	•				•								
14,75	•													
14,80						•								
14,90		•												
15,00	•	•				•								
15,20		•												
15,25	•	•												

СВЕРЛА

10xD ИЗ БЫСТРОРЕЖУЩЕЙ СТАЛИ HSS, HSSE



STAMO

универсальное применение

Система обозначений	
d1	Диаметр режущей части, мм
Лобц	Общая длина, мм
l2	Длина рабочей части, мм

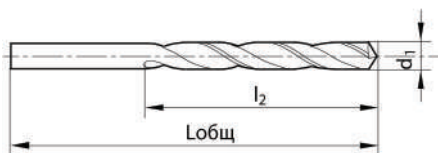

сверла
HSS, HSSE



Глубина обработки	10xD	10xD	10xD	10xD		
Материал	HSS	HSS	HSS	HSSE		
Покрытие	BR	V	TiN	NiTi		
Угол при вершине	118°	118°	118°	130°		
Тип						
Группы обрабатываемых материалов Основное применение	P	•	•	•		
	M	•	•	•		
	N	•	•	•	•	
	K	•	•	•	•	
	S					
	H					
d1	Лобц	l2	Артикулы			
STD1146 STD1140 STD3140 STD3247						
15,50	227,0	149,0	•	•	•	
15,60			•			
15,75			•			
16,00	235,0	154,0	•	•	•	•
16,25			•			
16,50			•			
16,75			•			
17,00	241,0	158,0	•	•		
17,25			•			
17,50			•			
17,75	247,0	162,0	•	•		
18,00			•			
18,25			•			
18,50	254,0	166,0	•	•		
18,75			•			
19,00			•			
19,25	261,0	171,0	•	•		
19,50			•			
19,75			•			
20,00	268,0	176,0	•	•		
20,50			•			
21,00			•			
21,50	275,0	180,0	•	•		
22,00			•			
23,50			•			

СВЕРЛА УДЛИНЕННЫЕ

15xD ИЗ БЫСТРОРЕЖУЩЕЙ СТАЛИ HSS, HSSE



STAMO

универсальное применение

Система обозначений

d1	Диаметр режущей части, мм
Лобц	Общая длина, мм
l2	Длина рабочей части, мм

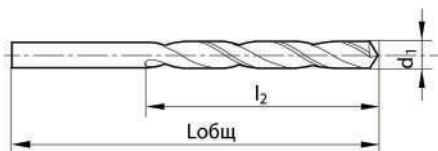

Сверла
HSS, HSSE

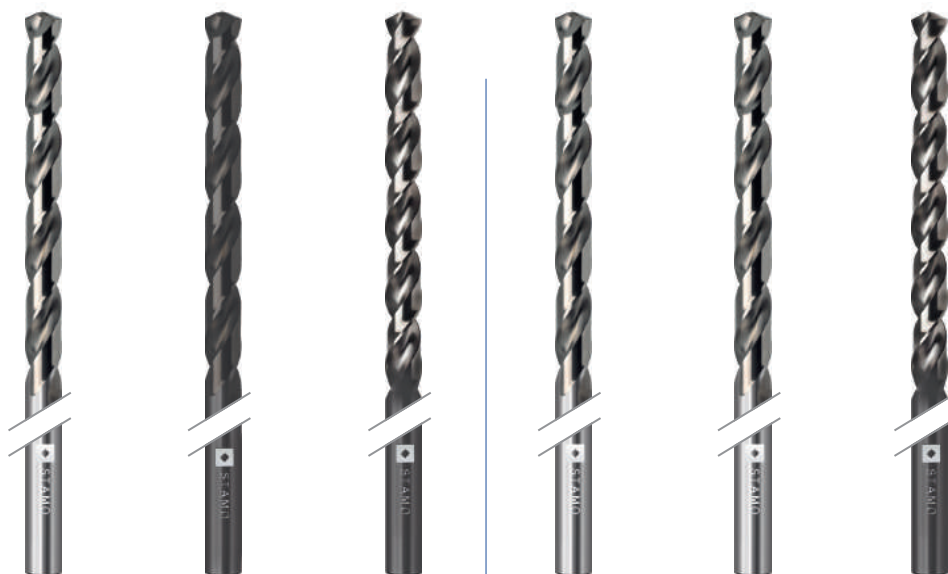

Глубина обработки		15xD	15xD	15xD	15xD	15xD	15xD
Материал		HSS	HSS	HSS	HSSE	HSSE	HSSE
Покрытие		BR	V	Nit	BR	BR	Nit
Угол при вершине		118°	118°	130°	130°	130°	130°
Группы обрабатываемых материалов Основное применение	P	•	•	•	•	•	•
	M					o	•
	N	o	o	•	•	o	•
	K	•	•	•	•	•	•
	S					o	
	H						o

d1	Лобц	l2	Артикулы					
			STD2150	STD1150	STD3150	STD1250	STD1256	STD3250
1,60	115,0	75,0		•				
1,80	120,0	80,0		•				
1,90								
2,00	125,0	85,0	•	•	•	•		
		93,0					•	
2,10		85,0	•					
		93,0					•	
2,20	135,0	90,0	•	•	•	•		
2,25								
2,30	125,0	93,0	•	•	•		•	
	135,0	90,0	•	•	•			
2,40	140,0	95,0	•	•	•			
	125,0	93,0					•	
2,50	140,0	95,0	•	•	•	•	•	
	125,0	93,0					•	
2,60	125,0	93,0					•	
	140,0	95,0	•					
2,70	125,0	93,0					•	
	150,0	100,0	•	•	•			
2,80	125,0	93,0					•	
	150,0	100,0	•	•		•		
2,85	125,0	93,0					•	
	150,0	100,0	•	•	•			
2,90	125,0	93,0					•	
	150,0	100,0	•	•	•			
2,95	125,0	93,0					•	
	150,0	100,0	•	•	•	•	•	
3,00	125,0	93,0					•	
	150,0	100,0	•	•	•	•	•	
3,10	155,0	105,0	•	•	•			
3,17	155,0	105,0			•			

СВЕРЛА УДЛИНЕННЫЕ

15xD ИЗ БЫСТРОРЕЖУЩЕЙ СТАЛИ HSS, HSSE



STAMO

универсальное применение

Система обозначений	
d1	Диаметр режущей части, мм
Лобц	Общая длина, мм
l2	Длина рабочей части, мм

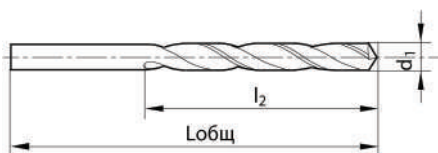

сверла
HSS, HSSE

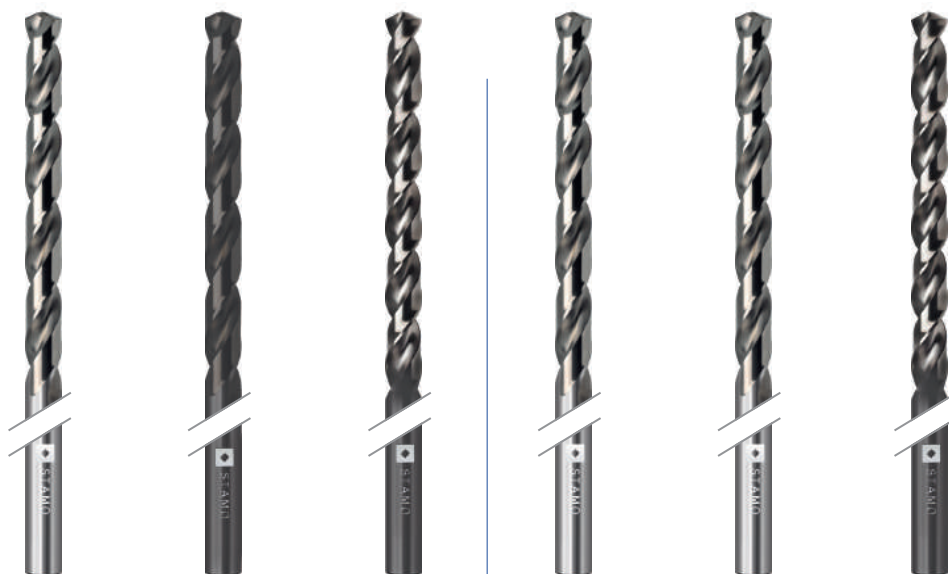

Глубина обработки		15xD	15xD	15xD	15xD	15xD	15xD
Материал		HSS	HSS	HSS	HSSE	HSSE	HSSE
Покрытие		BR	V	Nit	BR	BR	Nit
Угол при вершине		118°	118°	130°	130°	130°	130°
Группы обрабатываемых материалов Основное применение	P	•	•	•	•	•	•
	M					o	•
	N	o	o	•		o	•
	K	•	•	•	•	•	•
	S					o	
	H						o

d1	Лобц	l2	Артикулы					
			STD2150	STD1150	STD3150	STD1250	STD1256	STD3250
3,20	155,0	105,0	•	•	•	•		
3,25	155,0	105,0	•	•				
3,30	155,0	105,0	•	•	•			
	160,0	120,0					•	
3,40	165,0	115,0	•	•	•			
3,50	160,0	120,0					•	
3,70	165,0	115,0	•	•	•	•		
3,75			•	•	•			
3,80			•	•	•	•		
3,90	175,0	120,0	•	•	•			
4,00			•	•	•		•	
4,10			•	•	•	•		•
4,20			•	•	•	•	•	
4,25	175,0		•	•	•			
4,30	185,0	125,0	•	•				•
4,40			•					
4,50	160,0	120,0					•	
4,60	185,0	125,0	•	•	•	•		•
	200,0	150,0					•	
4,70	185,0	125,0	•	•	•			•
	200,0	150,0					•	
4,75	185,0	125,0	•					
4,76	195,0	135,0	•	•	•	•		•
4,80			•	•	•	•	•	
4,90	200,0	150,0					•	
	195,0	135,0	•	•				•
	200,0	150,0					•	

СВЕРЛА УДЛИНЕННЫЕ

15xD ИЗ БЫСТРОРЕЖУЩЕЙ СТАЛИ HSS, HSSE



STAMO

универсальное применение

Система обозначений

d1	Диаметр режущей части, мм
Лобц	Общая длина, мм
l2	Длина рабочей части, мм

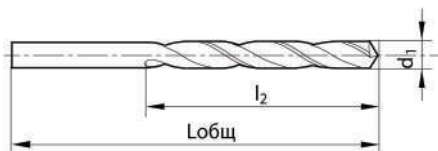

Сверла
HSS, HSSE

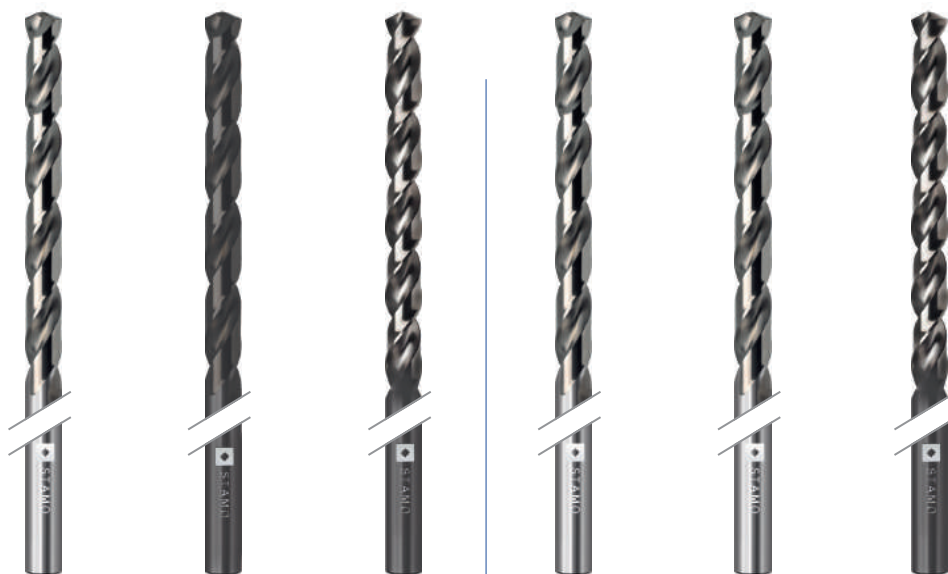

Глубина обработки		15xD	15xD	15xD	15xD	15xD	15xD
Материал		HSS	HSS	HSS	HSSE	HSSE	HSSE
Покрытие		BR	V	Nit	BR	BR	Nit
Угол при вершине		118°	118°	130°	130°	130°	130°
Группы обрабатываемых материалов Основное применение	P	•	•	•	•	•	•
	M					o	•
	N	o	o	•		o	•
	K	•	•	•	•	•	•
	S					o	
	H						o

d1	Лобц	l2	Артикулы					
			STD2150	STD1150	STD3150	STD1250	STD1256	STD3250
5,00	195,0	135,0	•	•	•	•		•
	200,0	150,0					•	
5,10	195,0	135,0	•	•	•			
	200,0	150,0					•	
5,20	195,0	135,0	•	•	•	•		
	200,0	150,0					•	
5,25	195,0	135,0	•	•	•			
	200,0	150,0					•	
5,30	195,0	135,0	•	•	•			
	200,0	150,0					•	
5,40	205,0	140,0	•	•	•			•
	200,0	150,0					•	
5,50	205,0	140,0	•	•	•	•		•
	200,0	150,0					•	
5,60	205,0	140,0	•	•	•			•
	200,0	150,0					•	
5,70	205,0	140,0	•	•	•			•
	200,0	150,0					•	
5,75	205,0	140,0	•	•	•			•
	200,0	150,0					•	
5,80	205,0	140,0	•	•	•	•		•
	200,0	150,0					•	
5,90	205,0	140,0	•	•	•			•
	200,0	150,0					•	
6,00	205,0	140,0	•	•	•	•		•
	200,0	150,0					•	
6,10	205,0	150,0	•	•	•			•
	215,0						•	
6,20	205,0	150,0	•	•	•			•
	215,0						•	
6,25	205,0	150,0	•	•	•			•
	215,0						•	
6,30	200,0	150,0	•	•	•			•
	215,0						•	
6,40	200,0	150,0	•	•	•			•
	215,0						•	

СВЕРЛА УДЛИНЕННЫЕ

15xD ИЗ БЫСТРОРЕЖУЩЕЙ СТАЛИ HSS, HSSE



STAMO

универсальное применение

Система обозначений	
d1	Диаметр режущей части, мм
Лобц	Общая длина, мм
l2	Длина рабочей части, мм

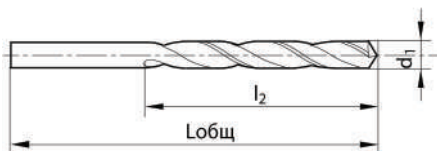

сверла
HSS, HSSE



Глубина обработки		15xD	15xD	15xD	15xD	15xD	15xD
Материал		HSS	HSS	HSS	HSSE	HSSE	HSSE
Покрытие		BR	V	Nit	BR	BR	Nit
Угол при вершине		118°	118°	130°	130°	130°	130°
Группы обрабатываемых материалов Основное применение	P	•	•	•	•	•	•
	M	•	•	•	•	•	•
	N	o	o	•	•	o	•
	K	•	•	•	•	•	•
	S	•	•	•	•	o	•
	H	•	•	•	•	•	o

d1	Лобц	l2	Артикулы					
			STD2150	STD1150	STD3150	STD1250	STD1256	STD3250
6,50	200,0	150,0						
	215,0	150,0	•	•	•	•	•	•
6,60	200,0	150,0						
	215,0	150,0	•	•	•		•	
6,70	200,0	150,0						
	215,0	150,0	•	•			•	
6,75	200,0	150,0						
	215,0	150,0	•					
6,80	200,0	150,0						
	225,0	155,0	•	•	•		•	
6,90	200,0	150,0						
	225,0	155,0	•				•	
7,00	200,0	150,0						
	225,0	155,0	•	•	•	•	•	•
7,10	200,0	150,0						
	225,0	155,0	•	•	•		•	
7,20	200,0	150,0						
	225,0	155,0	•				•	
7,25	200,0	150,0						
	225,0	155,0	•				•	
7,30	200,0	150,0						
	225,0	155,0	•		•		•	
7,40	200,0	150,0						
	225,0	155,0	•				•	
7,50	200,0	150,0						
	225,0	155,0	•	•	•	•	•	
7,60	240,0	165,0	•	•				
7,70			•	•				
7,75			•	•				
7,80			•	•				
7,90			•	•				
7,90			•	•				
8,00	200,0	150,0						
	240,0	165,0	•	•	•	•	•	•
8,10	240,0	165,0	•	•	•			

СВЕРЛА УДЛИНЕННЫЕ

15xD ИЗ БЫСТРОРЕЖУЩЕЙ СТАЛИ HSS, HSSE



универсальное применение

Система обозначений

d1	Диаметр режущей части, мм
Лобц	Общая длина, мм
l2	Длина рабочей части, мм

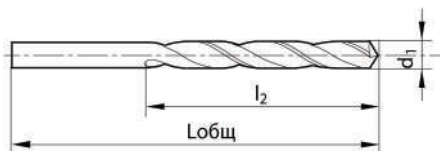

Сверла
HSS, HSSE

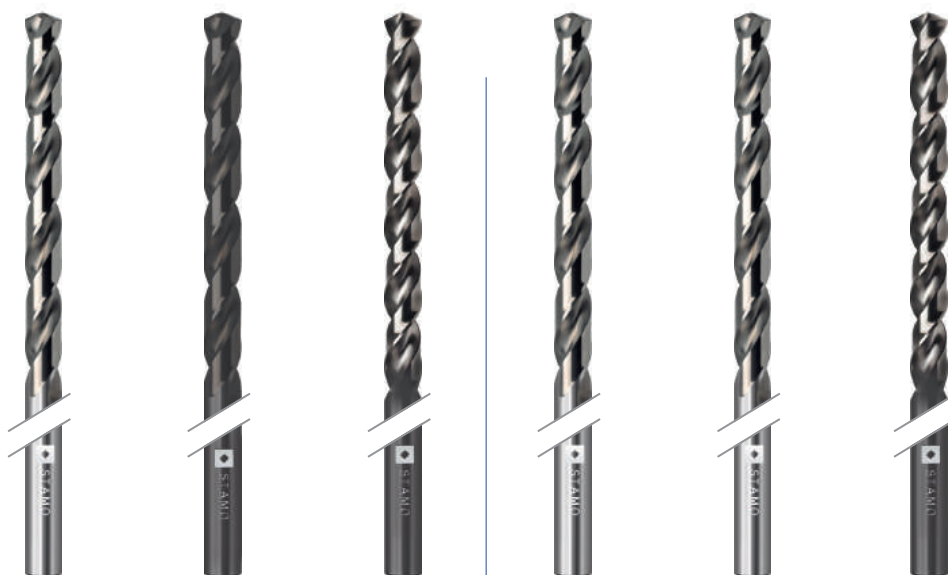

Глубина обработки		15xD	15xD	15xD	15xD	15xD	15xD
Материал		HSS	HSS	HSS	HSSE	HSSE	HSSE
Покрытие		BR	V	Nit	BR	BR	Nit
Угол при вершине		118°	118°	130°	130°	130°	130°
Группы обрабатываемых материалов Основное применение	P	•	•	•	•	•	•
	M	•	•	•	•	•	•
	N	o	o	•	•	o	•
	K	•	•	•	•	•	•
	S	•	•	•	•	o	•
	H	•	•	•	•	•	o

d1	Лобц	l2	Артикулы							
			STD2150	STD1150	STD3150	STD1250	STD1256	STD3250		
8,20	240,0	165,0	•	•	•			•		
8,25	240,0	165,0	•							
8,30	240,0	165,0	•							
8,40	240,0	165,0	•		•					
8,50	200,0	150,0					•			
	240,0	165,0	•	•	•	•		•		
8,60	250,0	175,0	•	•						
8,70			•							
8,75			•							
8,80			•	•		•				
8,90			•							
9,00			200,0	150,0					•	
9,10	250,0	175,0	•	•	•	•		•		
			•							
			•		•					
			•							
			•							
			•							
9,50	200,0	150,0					•			
	250,0	175,0	•	•	•	•		•		
9,60	265,0	185,0	•		•					
			•	•	•					
			•							
			•							
			•							
			•							
10,00	200,0	150,0					•			
	265,0	185,0	•	•	•	•		•		
10,10	265,0	185,0	•							
10,20	265,0	185,0	•	•	•					
10,25	265,0	185,0	•							
10,30	265,0	185,0	•							
10,40	265,0	185,0	•							
10,50	265,0	185,0	•	•	•	•				

СВЕРЛА УДЛИНЕННЫЕ

15xD ИЗ БЫСТРОРЕЖУЩЕЙ СТАЛИ HSS, HSSE



STAMO

универсальное применение

Система обозначений	
d1	Диаметр режущей части, мм
Лобц	Общая длина, мм
l2	Длина рабочей части, мм

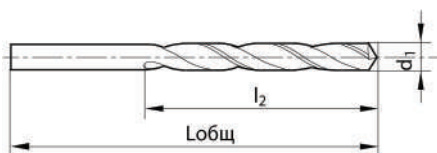

сверла
HSS, HSSE

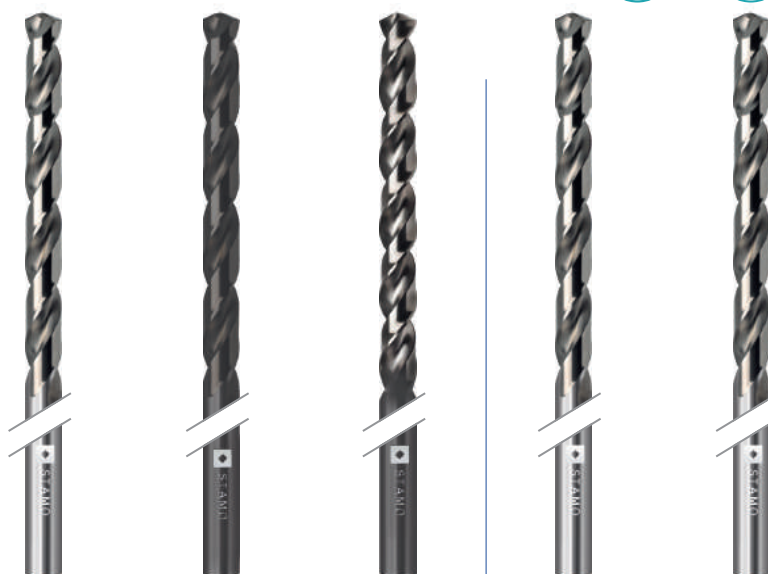

Глубина обработки	15xD	15xD	15xD	15xD	15xD		
Материал	HSS	HSS	HSS	HSSE	HSSE		
Покрyтие	BR	V	Nit	BR	BR		
Угол при вершине	118°	118°	130°	130°	130°		
Группы обрабатываемых материалов Основное применение	P	•	•	•	•		
	M				o		
	N	o	o	•	o		
	K	•	•	•	•		
	S					o	
	H						
d1	Лобц	l2	Артикулы				
			STD2150	STD1150	STD3150	STD1250	STD1256
10,50	250,0	187,0					•
10,60	265,0	185,0	•				
10,70	280,0	195,0	•				
10,75			•				
10,80			•				
10,90			•				
11,00	250,0	187,0		•	•	•	•
11,10	280,0	195,0	•				
11,20			•				
11,25			•				
11,30			•				
11,40			•				
11,50	250,0	187,0		•	•	•	•
11,60	280,0	195,0	•		•		
11,70			•				
11,75			•				
11,80			•		•		
11,90	295,0	205,0	•		•		
12,00	250,0	187,0		•	•	•	•
12,10	295,0	205,0	•		•		
12,20			•				
12,25			•				
12,30			•				
12,40			•				
12,50	250,0	187,0		•	•	•	•
12,60	295,0	205,0	•		•		
12,70			•				
12,75			•				
12,80			•				
12,90			•				
13,00	250,0	187,0			•		•
	295,0	205,0	•	•	•	•	

СВЕРЛА УДЛИНЕННЫЕ

20xD ИЗ БЫСТРОРЕЖУЩЕЙ СТАЛИ HSS, HSSE



STAMO

универсальное применение

Система обозначений	
d1	Диаметр режущей части, мм
Лобц	Общая длина, мм
l2	Длина рабочей части, мм

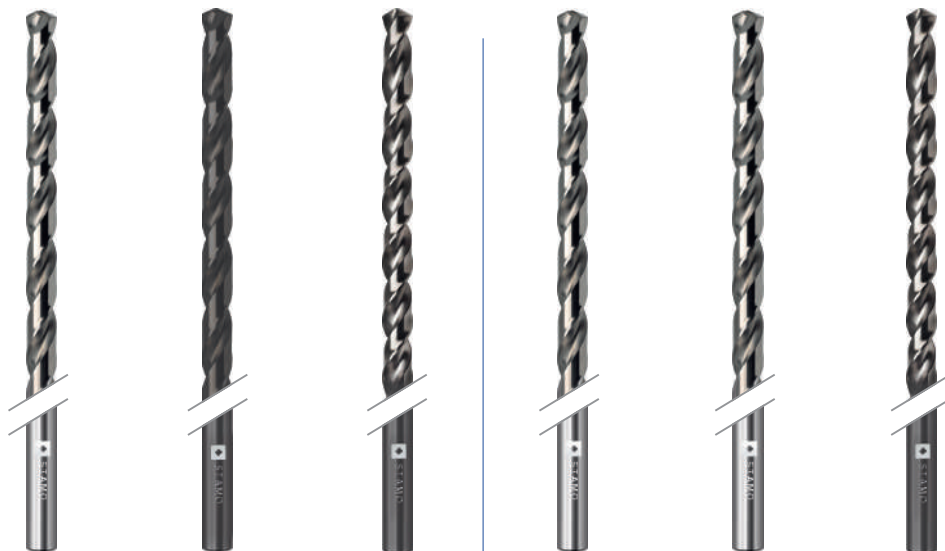
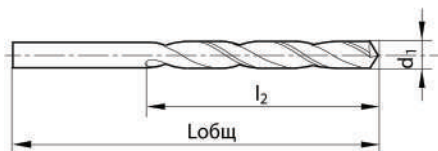

Глубина обработки	20xD	20xD	20xD	20xD	20xD	20xD
Материал	HSS	HSS	HSS	HSSE	HSSE	HSSE
Покрытие	BR	V	Nit	BR	BR	Nit
Угол при вершине	118°	118°	130°	130°	130°	130°
Группы обрабатываемых материалов Основное применение	P	•	•	•	•	•
	M	•	•	•	•	•
	N	•	•	•	•	•
	K	•	•	•	•	•
	S	•	•	•	•	•
	H	•	•	•	•	•

d1	Лобц	l2	Артикулы					
			STD2160	STD1160	STD3160	STD1260	STD1266	STD3260
2,00	160,0	110,0			•			
2,10						•		
2,20							•	
2,30							•	
2,40							•	
2,50	180,0	120,0			•			
2,70	190,0		130,0	•				
2,75				•				
2,80	160,0		120,0					•
	190,0		130,0	•		•		
2,90	160,0	120,0					•	
	190,0	130,0	•					
3,00	160,0	120,0					•	
	190,0	130,0	•	•	•	•		
3,10	200,0	135,0	•					
		150,0					•	
3,17		135,0		•				•
3,20		150,0		•		•		•
3,25		135,0	150,0	•				•
3,30				•	•			
3,40		150,0					•	
		210,0	145,0	•				
3,50		200,0	150,0					•
		210,0	145,0	•	•	•	•	•
3,60	200,0	150,0					•	
	210,0	145,0	•					
3,70	200,0	150,0					•	
	210,0	145,0	•					
3,75	210,0		•					
3,80	200,0	150,0					•	
	220,0	150,0	•			•		
3,90	200,0	150,0					•	

СВЕРЛА УДЛИНЕННЫЕ

20xD ИЗ БЫСТРОРЕЖУЩЕЙ СТАЛИ HSS, HSSE



STAMO

универсальное применение

Система обозначений	
d1	Диаметр режущей части, мм
Лобц	Общая длина, мм
l2	Длина рабочей части, мм

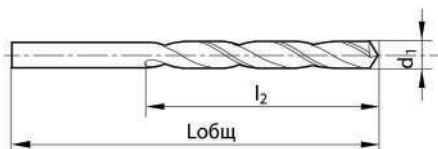

сверла
HSS, HSSE

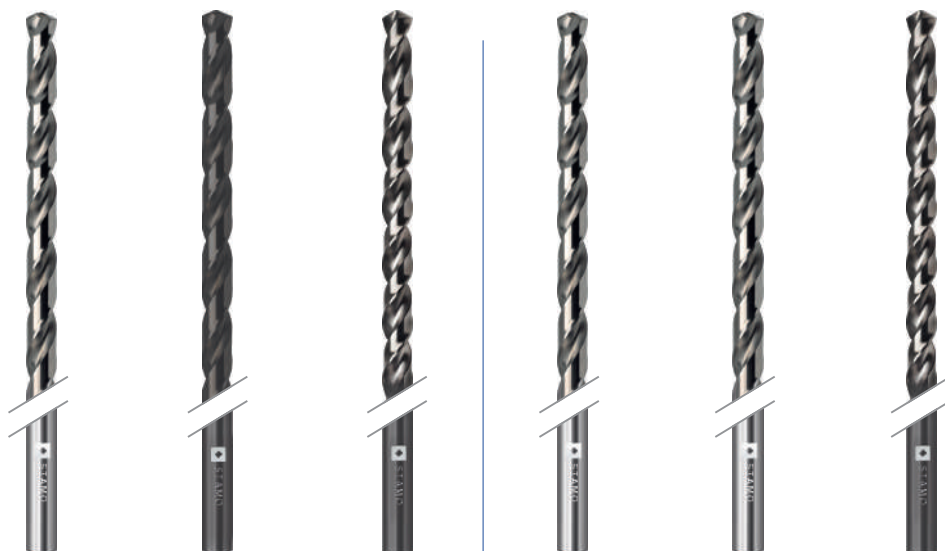

Глубина обработки	20xD	20xD	20xD	20xD	20xD	20xD
Материал	HSS	HSS	HSS	HSSE	HSSE	HSSE
Покрытие	BR	V	Nit	BR	BR	Nit
Угол при вершине	118°	118°	130°	130°	130°	130°
Группы обрабатываемых материалов Основное применение	P	•	•	•	•	•
	M	•	•	•	•	•
	N	•	•	•	•	•
	K	•	•	•	•	•
	S	•	•	•	•	•
	H	•	•	•	•	•

d1	Лобц	l2	Артикулы					
			STD2160	STD1160	STD3160	STD1260	STD1266	STD3260
3,90	220,0	150,0	•					
			•					
4,00	220,0		•	•	•	•	•	•
			•					
4,10	220,0		•		•		•	
			•					
4,20	220,0		•		•		•	•
			•					
4,25	220,0		•					
			•					
4,30	235,0	160,0	•				•	
		•						
4,40	200,0	150,0					•	
		235,0	160,0	•				
4,50	200,0	150,0					•	
		235,0	160,0	•	•	•		
4,60	250,0	187,0	•				•	
		•						
4,70	235,0	160,0	•					
		250,0	187,0	•			•	
4,75	235,0	160,0	•					
		245,0	170,0	•	•		•	
4,80	250,0	187,0	•				•	
		245,0	170,0	•				
4,90	250,0	187,0					•	
		245,0	170,0	•	•	•		•
5,00	245,0	170,0	•				•	
		250,0	187,0	•			•	•
5,10	245,0	170,0	•				•	
		250,0	187,0	•			•	
5,20	245,0	170,0	•	•		•		
		250,0	187,0	•			•	
5,25	245,0	170,0	•					
		•						
5,30	250,0	187,0	•				•	
		•						
5,40	260,0	180,0	•				•	
		250,0	187,0	•			•	
5,50	260,0	180,0	•	•	•	•	•	
		•						

СВЕРЛА УДЛИНЕННЫЕ

20xD ИЗ БЫСТРОРЕЖУЩЕЙ СТАЛИ HSS, HSSE



STAMO

универсальное применение

Система обозначений	
d1	Диаметр режущей части, мм
Лобц	Общая длина, мм
l2	Длина рабочей части, мм

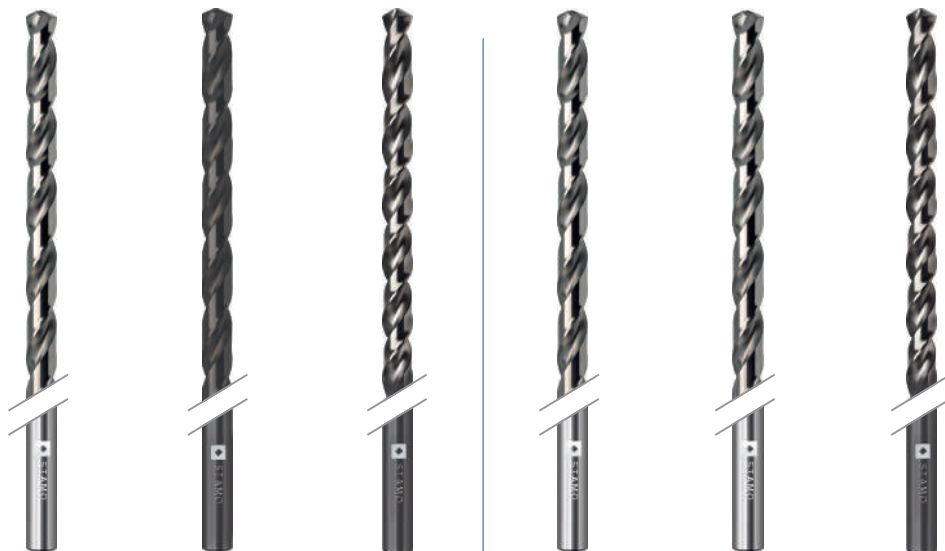
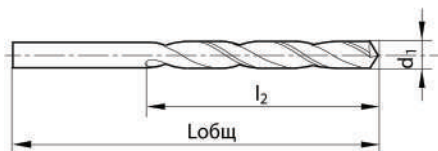

Глубина обработки	20xD	20xD	20xD	20xD	20xD	20xD
Материал	HSS	HSS	HSS	HSSE	HSSE	HSSE
Покрyтие	BR	V	Nit	BR	BR	Nit
Угол при вершине	118°	118°	130°	130°	130°	130°
Группы обрабатываемых материалов Основное применение	P	•	•	•	•	•
	M	•	•	•	•	•
	N	•	•	•	•	•
	K	•	•	•	•	•
	S	•	•	•	•	•
	H	•	•	•	•	•

d1	Лобц	l2	Артикулы					
			STD2160	STD1160	STD3160	STD1260	STD1266	STD3260
5,60	250,0	187,0				•		
	260,0	180,0	•					
5,70	250,0	187,0				•		
	260,0	180,0	•					
5,75	260,0	180,0	•					
5,80	250,0	187,0				•		
	260,0	180,0	•	•		•		
5,90	250,0	187,0				•		
	260,0	180,0	•					
6,00	250,0	187,0				•		
	260,0	180,0	•	•	•	•		•
6,10	250,0	187,0				•		
	275,0	190,0	•					
6,20	250,0	187,0				•		
	275,0	190,0	•					•
6,25	275,0	190,0	•					
	275,0	190,0	•					
6,30	250,0	187,0				•		
	275,0	190,0	•					
6,35	275,0	190,0					•	
6,40	250,0	187,0				•		
	275,0	190,0	•					
6,50	250,0	187,0				•		
	275,0	190,0	•	•	•	•		•
	250,0	187,0	•			•		
6,60	250,0	187,0				•		
	275,0	190,0	•					
	250,0	187,0				•		
6,70	250,0	187,0				•		
	275,0	190,0	•					
6,75	250,0	187,0				•		
	275,0	190,0	•					
6,80	250,0	187,0				•		
	290,0	200,0	•	•				
6,90	250,0	187,0				•		
	290,0	200,0	•					
7,00	250,0	187,0				•		
	290,0	200,0	•	•	•	•		•
7,10	250,0	187,0				•		
	290,0	200,0	•					

СВЕРЛА УДЛИНЕННЫЕ

20xD ИЗ БЫСТРОРЕЖУЩЕЙ СТАЛИ HSS, HSSE



STAMO

универсальное применение

Система обозначений	
d1	Диаметр режущей части, мм
Лобц	Общая длина, мм
l2	Длина рабочей части, мм

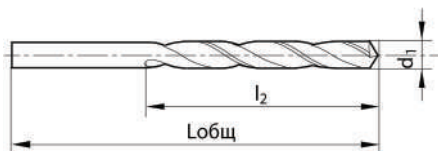

HSS

HSSE

118°

130°

RH

DIN 1869

OCT

сверла HSS, HSSE

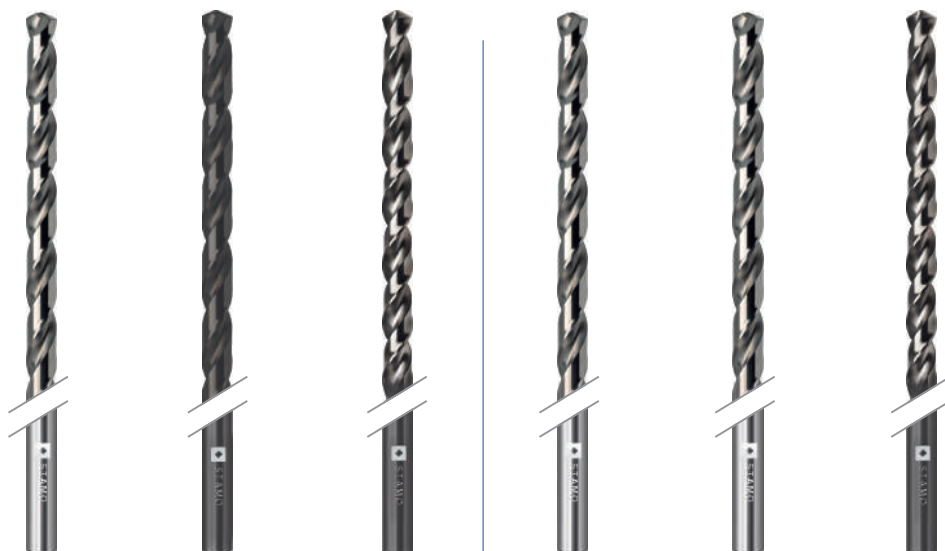

Глубина обработки	20xD	20xD	20xD	20xD	20xD	20xD
Материал	HSS	HSS	HSS	HSSE	HSSE	HSSE
Покрытие	BR	V	Nit	BR	BR	Nit
Угол при вершине	118°	118°	130°	130°	130°	130°
Группы обрабатываемых материалов Основное применение	P	•	•	•	•	•
	M	•	•	•	•	•
	N	•	•	•	•	•
	K	•	•	•	•	•
	S	•	•	•	•	•
	H	•	•	•	•	•

d1	Лобц	l2	Артикулы							
			STD2160	STD1160	STD3160	STD1260	STD1266	STD3260		
7,20	250,0	187,0					•			
7,25	290,0	200,0	•							
			•							
7,30	250,0	187,0					•			
	290,0	200,0	•							
7,40	250,0	187,0					•			
	290,0	200,0	•							
7,50	250,0	187,0					•			
	290,0	200,0	•		•	•		•		
7,60	305,0	210,0	•							
7,70			•							
7,75			•							
7,80			•							
7,90			•							
			•							
8,00	250,0	187,0					•			
8,10	305,0	210,0	•	•	•	•		•		
			•							
			•		•					
			•							
			•							
			•							
8,50	250,0	187,0					•			
	305,0	210,0	•	•	•	•		•		
8,60	320,0	220,0	•							
8,70			•							
8,75			•							
8,80			•							
8,90			•							
9,00	250,0	187,0					•			
9,10	320,0	220,0	•	•	•	•		•		
			•							
			•							
			•							
			•							
			•							
9,20										
9,25										
9,30										
9,40										

СВЕРЛА УДЛИНЕННЫЕ

20xD ИЗ БЫСТРОРЕЖУЩЕЙ СТАЛИ HSS, HSSE



STAMO

универсальное применение

Система обозначений	
d1	Диаметр режущей части, мм
Лобц	Общая длина, мм
l2	Длина рабочей части, мм

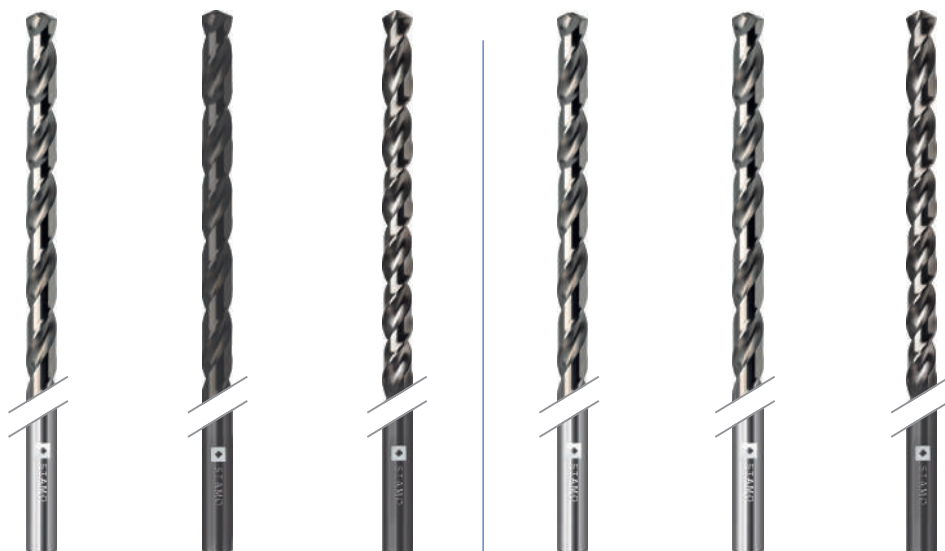
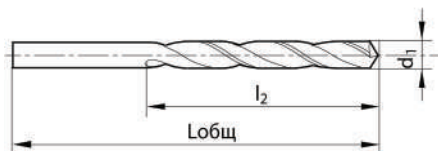

Глубина обработки	20xD	20xD	20xD	20xD	20xD	20xD
Материал	HSS	HSS	HSS	HSSE	HSSE	HSSE
Покрытие	BR	V	Nit	BR	BR	Nit
Угол при вершине	118°	118°	130°	130°	130°	130°
Группы обрабатываемых материалов Основное применение	P	•	•	•	•	•
	M	•	•	•	•	•
	N	•	•	•	•	•
	K	•	•	•	•	•
	S	•	•	•	•	•
	H	•	•	•	•	•

d1	Лобц	l2	Артикулы					
			STD2160	STD1160	STD3160	STD1260	STD1266	STD3260
9,50	250,0	187,0					•	
	320,0	220,0	•	•	•	•		
9,60	340,0	235,0	•					
9,70			•					
9,75			•					
9,80			•		•			
9,90			•					
10,00			250,0	187,0	•	•		
10,10	340,0	235,0	•			•		
10,20			•		•			
10,25			•					
10,30			•					
10,40			•					
10,50			315,0		•			
10,60	340,0	235,0	•	•		•		
10,70			•					
10,72			•					
10,75			•		•			
10,80			•					
10,90			•					
11,00	315,0	235,0	•	•			•	
11,10	365,0	250,0	•	•	•	•		
11,20			•					
11,25			•					
11,30			•					
11,40			•					
11,50			315,0	235,0	•	•		
11,60	365,0	250,0	•	•	•	•		
11,70			•					
11,75			•					
11,80			•					

СВЕРЛА УДЛИНЕННЫЕ

20xD ИЗ БЫСТРОРЕЖУЩЕЙ СТАЛИ HSS, HSSE



STAMO

универсальное применение

Система обозначений	
d1	Диаметр режущей части, мм
Лобц	Общая длина, мм
l2	Длина рабочей части, мм

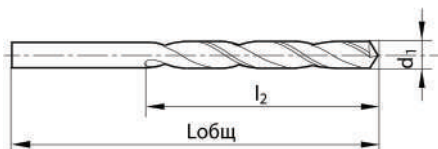

сверла HSS, HSSE

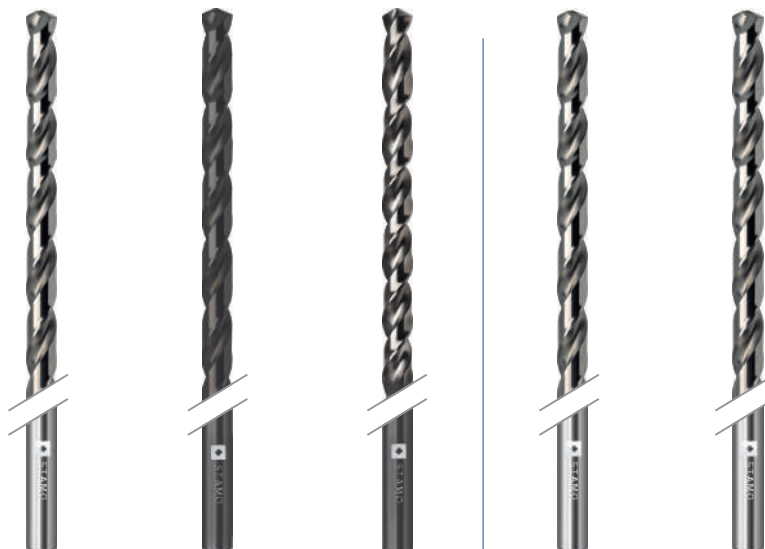

Глубина обработки	20xD	20xD	20xD	20xD	20xD		
Материал	HSS	HSS	HSS	HSSE	HSSE		
Покрытие	BR	V	Nit	BR	BR		
Угол при вершине	118°	118°	130°	130°	130°		
Группы обрабатываемых материалов Основное применение	P	•	•	•	•		
	M	•	•	•	•		
	N	•	•	•	•		
	K	•	•	•	•		
	S	•	•	•	•		
	H	•	•	•	•		
d1	Лобц	l2	Артикулы				
			STD2160	STD1160	STD3160	STD1260	STD1266
11,90	375,0	260,0	•				
12,00	315,0	235,0					•
12,10	375,0	260,0	•	•	•		
12,20			•				
12,25			•				
12,30			•				
12,40			•				
12,50	315,0	235,0					•
12,60	375,0	260,0	•		•		
12,70			•				
12,75			•				
12,80			•				
12,90			•				
13,00	315,0	235,0					•
	375,0	260,0	•		•	•	

универсальное применение

сверла
HSS, HSSE

Система обозначений	
d1	Диаметр режущей части, мм
Лобц	Общая длина, мм
l2	Длина рабочей части, мм

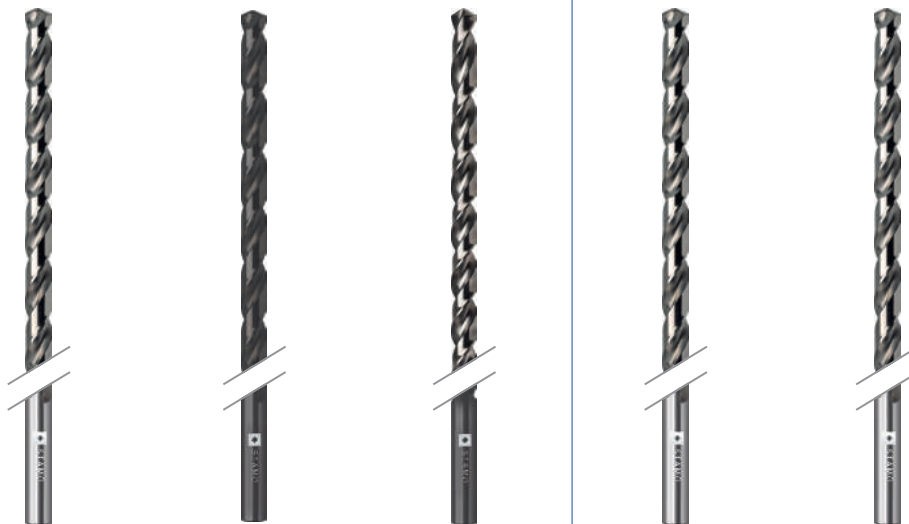
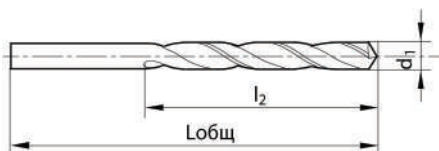

Глубина обработки	25xD	25xD	25xD	25xD	25xD
Материал	HSS	HSS	HSS	HSSE	HSSE
Покрытие	BR	V	Nit	BR	BR
Угол при вершине	118°	118°	130°	130°	130°
Группы обрабатываемых материалов Основное применение	P	•	•	•	•
	M			o	
	N	o	o	•	•
	K	•	•	•	•
	S				o
	H				

d1	Лобц	l2	Артикулы				
			STD2170	STD1170	STD3170	STD1270	STD1276
3,00	200,0	150,0					•
	240,0	160,0			•		
3,17	250,0	170,0			•		
3,20		187,0					•
3,40		187,0					•
3,50		187,0					•
3,70	265,0	180,0	•		•	•	
	265,0	180,0			•		
3,80	250,0	187,0					•
	280,0	190,0	•			•	
3,90	250,0	187,0					•
	250,0	187,0					•
4,00	280,0	190,0	•		•	•	
	250,0	187,0		•			•
4,10	250,0	187,0					•
	250,0	187,0					•
4,20	280,0	190,0	•		•	•	
	250,0	187,0					•
4,50	295,0	200,0	•		•	•	
	295,0	200,0	•				•
4,80	315,0	210,0	•				•
	315,0	235,0					•
5,00	315,0	210,0	•	•	•	•	
	315,0	235,0					•
5,10	315,0	210,0			•		
5,20	315,0	210,0	•				•
	315,0	235,0					•
5,50	330,0	225,0	•	•	•		
	315,0	235,0					•
5,80	330,0	225,0	•	•			•
	330,0	225,0					•
5,90	330,0	225,0		•			•
	315,0	235,0					•
6,00	330,0	225,0	•	•	•	•	
	330,0	235,0					•
6,35	315,0	235,0			•		
6,50	315,0	235,0					•

СВЕРЛА

25xD ИЗ БЫСТРОРЕЖУЩЕЙ СТАЛИ HSS, HSSE



STAMO

универсальное применение

Система обозначений	
d1	Диаметр режущей части, мм
Лобц	Общая длина, мм
l2	Длина рабочей части, мм

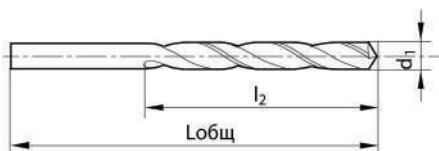

сверла
HSS, HSSE

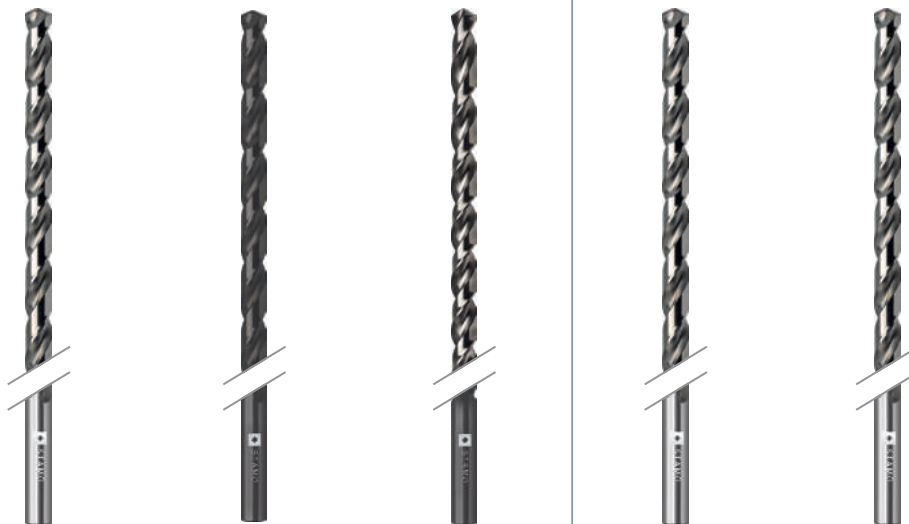

Глубина обработки	25xD	25xD	25xD	25xD	25xD
Материал	HSS	HSS	HSS	HSSE	HSSE
Покрытие	BR	V	Nit	BR	BR
Угол при вершине	118°	118°	130°	130°	130°
Группы обрабатываемых материалов Основное применение	P	•	•	•	•
	M	•	•	•	•
	N	o	o	•	•
	K	•	•	•	•
	S	•	•	•	•
	H	•	•	•	•

d1	Лобц	l2	Артикулы				
			STD2170	STD1170	STD3170	STD1270	STD1276
6,50	350,0	235,0	•		•		
	315,0	235,0					•
6,80	370,0	250,0	•		•		
	315,0	235,0					•
7,00	370,0	250,0	•	•	•	•	
	315,0	235,0					•
7,50	370,0	250,0	•	•	•		
	390,0	265,0		•			
8,00	315,0	235,0					•
	390,0	265,0	•	•	•	•	
8,20	390,0	265,0			•		
	315,0	235,0					•
8,50	390,0	265,0	•		•	•	
	315,0	235,0					•
9,00	410,0	280,0	•	•	•	•	
	315,0	235,0					•
9,50	410,0	280,0	•	•	•	•	
	430,0	295,0			•		
9,80	430,0	295,0	•				
	315,0	235,0					•
10,00	430,0	295,0	•	•	•	•	
	430,0	295,0	•				
10,30	430,0	295,0	•		•		
	430,0	295,0	•				
10,50	430,0	295,0	•		•		
	400,0	300,0					•
11,00	400,0	300,0					•
	455,0	310,0	•	•	•	•	
11,50	400,0	300,0					•
	455,0	310,0	•	•	•	•	
12,00	400,0	300,0					•
	480,0	330,0	•	•	•	•	
12,50	400,0	300,0					•
	480,0	330,0	•	•	•	•	
13,00	400,0	300,0					•
	480,0	330,0	•	•	•	•	

СВЕРЛА

>40xD ИЗ БЫСТРОРЕЖУЩЕЙ СТАЛИ HSS, HSSE



универсальное применение

Система обозначений	
d1	Диаметр режущей части, мм
Лобц	Общая длина, мм
l2	Длина рабочей части, мм

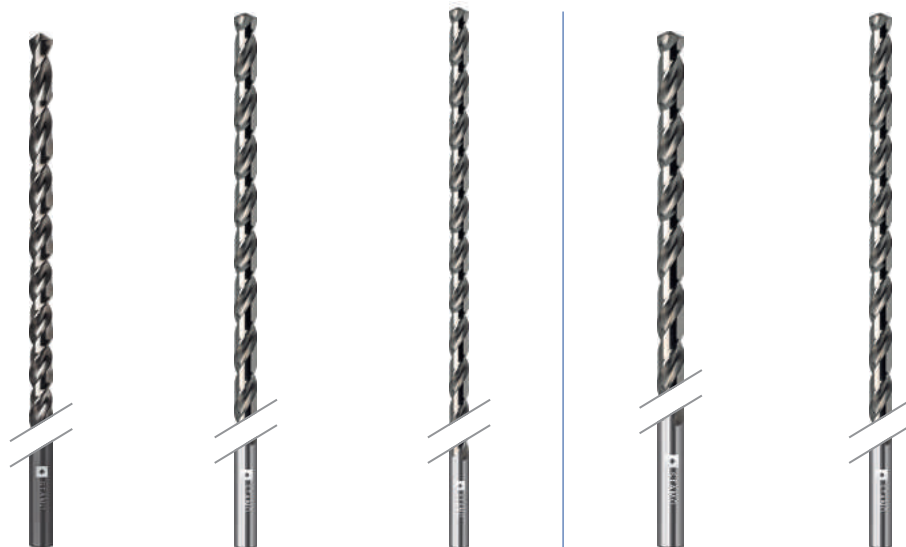
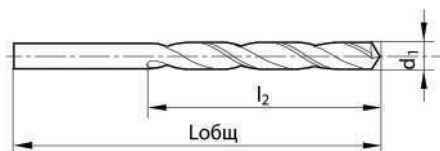

Глубина обработки		~45xD	~54xD	~74xD	~30xD	~45xD	
Материал		HSS	HSS	HSS	HSSE	HSSE	
Покрытие		Nit	BR	BR	BR	BR	
Угол при вершине		130°	130°	130°	130°	130°	
Группы обрабатываемых материалов Основное применение	P	•	•	•	•	•	
	M						
	N	•	•	•	•	•	
	K	•	•	•	•	•	
	S						
	H						
d1	Лобц	l2	Артикулы				
			STD3180	STD1180	STD1190	STD1286	STD1296
3,00	250,0	187,0				•	
4,00	315,0	235,0				•	
4,10	315,0	235,0				•	
4,20	315,0	235,0				•	
4,50	315,0	235,0				•	
5,00	400,0	300,0				•	
	500,0	450,0					•
5,50	400,0	300,0				•	
5,80	400,0	300,0				•	
	400,0	300,0				•	
6,00	400,0	400,0	•				
	500,0	450,0					•
	400,0	300,0				•	
6,50	400,0	300,0				•	
6,90	400,0	300,0				•	
7,00	400,0	300,0				•	
	500,0	450,0					•
7,50	400,0	300,0				•	
8,00	400,0	300,0				•	
	500,0	400,0	•				
	750,0	650,0		•			•
8,50	400,0	300,0				•	
9,00	500,0	450,0				•	
	400,0	300,0				•	
10,00	500,0	450,0					•
	600,0	500,0	•				
	750,0	650,0		•			
	1000,0	850,0			•		
11,00	500,0	450,0				•	
	600,0	500,0	•				
	750,0	650,0		•			
12,00	500,0	450,0				•	
	600,0	500,0	•				
	750,0	650,0		•			
	1000,0	850,0			•		
13,00	500,0	450,0				•	



универсальное применение

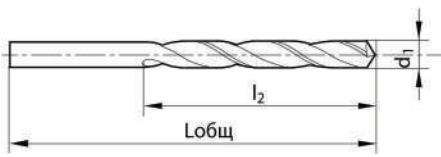

Система обозначений	
d1	Диаметр режущей части, мм
Лобц	Общая длина, мм
l2	Длина рабочей части, мм

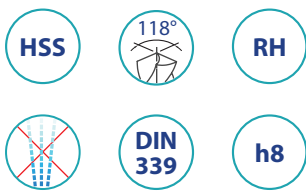

Глубина обработки		10xD		
Материал		HSS		
Покрытие		V		
Угол при вершине		118°		
Группы обрабатываемых материалов (свное применение)	P	•		
	K	•		
	N	o		
d1	Лобц	l2	Артикул	
STD1145				
0,80	42,0	22,0	•	
0,95	45,0	24,0	•	
1,00	48,0	26,0	•	
1,20	52,0	30,0	•	
1,25		•		
1,35	55,0	33,0	•	
1,40		•		
1,45		•		
1,50		•		
1,70	58,0	35,0	•	
1,80	62,0	38,0	•	
1,90		•		
1,99	66,0	41,0	•	
2,00		•		
2,10		•		
2,35		70,0	44,0	•
2,40	74,0	47,0	•	
2,45		•		
2,50		•		
2,60		•		
2,90		79,0	51,0	•
3,00			•	
3,05	84,0		55,0	•
3,10		•		
3,20		•		
3,25		•		
3,30		•		
3,40		91,0	60,0	•
3,50	•			
3,60	•			
3,70	•			
3,75	•			
3,80	96,0		64,0	•
3,90		•		
4,00		•		
4,05		•		
4,20	•			

d1	Лобц	l2	Артикул		
STD1145					
4,30	102,0	69,0	•		
4,40			•		
4,50			•		
4,60			•		
4,70			•		
4,80	108,0	74,0	•		
4,90			•		
5,00			•		
5,10			•		
5,20			•		
5,30			•		
5,35			116,0	80,0	•
5,40	•				
5,50	•				
5,55	•				
5,60	•				
5,70	•				
5,75	•				
5,80	•				
5,90	•				
5,95	•				
6,00	124,0	86,0	•		
6,20			•		
6,40			•		
6,50			•		
6,60			•		
6,70	133,0	93,0	•		
6,75			•		
6,90			•		
7,00			•		
7,10			•		
7,20			•		
7,30			142,0	100,0	•
7,40	•				
7,50	•				
7,60	•				
7,70	•				
7,80	•				
8,00	•				
8,25	•				
8,50	151,0	107,0			•
8,60					•
8,70			•		
8,80			•		
9,00			•		
9,10			•		
9,40	162,0	116,0	•		
9,50			•		
9,60			•		
9,80			•		
10,00			•		
10,20			•		
10,50	173,0	125,0	•		
10,60			•		
10,80			•		
11,00			•		
11,50			•		
11,75	184,0	134,0	•		
12,00			•		
12,20			•		
12,40			•		
12,50			•		
13,00			194,0	142,0	•
13,50	•				
14,00	•				
14,20	•				
14,50	202,0	147,0	•		
15,50			211,0	153,0	•
16,50	218,0	159,0	•		
18,00	226,0	165,0	•		
19,00	234,0	171,0	•		

сверла
HSS, HSS-E



С УСИЛЕННЫМ ХВОСТОВИКОМ ИЗ БЫСТРОРЕЖУЩЕЙ СТАЛИ HSSE

универсальное применение

сверла
HSS, HSSE

Система обозначений	
d1	диаметр режущей части, мм
Лобц	общая длина, мм
l2	длина рабочей части, мм
dxв	диаметр хвостовика, мм
lхв	длина хвостовика, мм

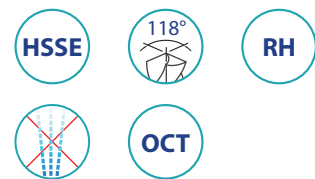
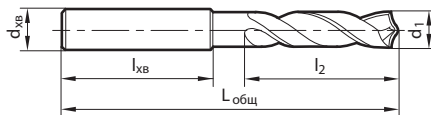

Глубина обработки		3xD	5xD				
Материал		HSSE-PM	HSSE-PM				
Покрытие		TiAIN	TiAIN				
Группы обрабатываемых материалов	P	•	•				
	M	•	•				
	N	•	•				
	K	•	•				
	S	•	•				
Основное применение		H					
d1	dxв	Лобц	l2	lхв	Артикулы		
						STD2231	STD2251
2	3	44	12	28	•	•	
		56	24		•	•	
2,1	3	44	12		•	•	
		56	24		•	•	
2,2	3	45	13		•	•	
		59	27		•	•	
2,3	3	45	13		•	•	
		59	27		•	•	
2,38	3	46	14		•	•	
		62	30		•	•	
2,4	3	46	14		•	•	
		62	30		•	•	
2,5	3	46	14		•	•	
		62	30		•	•	
2,6	3	46	14		•	•	
		62	30		•	•	
2,7	3	48	16		•	•	
		65	33		•	•	
2,78	3	48	16		•	•	
		65	33		•	•	
2,8	3	48	16		•	•	
		65	33		•	•	
2,9	3	48	16		•	•	
		65	33		•	•	
3	3	48	16		•	•	
		65	33		•	•	
3,1	4	50	18		•	•	
		68	36		•	•	
3,17	4	50	18	•	•		
		68	36	•	•		
3,2	4	50	18	•	•		
		68	36	•	•		
3,3	4	50	18	•	•		
		68	36	•	•		

3,4	4	52	20	28	•	•		
		71	39		•	•		
		3,5	4		52	20	•	•
					71	39	•	•
		3,57	4		52	20	•	•
					71	39	•	•
		3,6	4		52	20	•	•
					71	39	•	•
		3,7	4		52	20	•	•
					71	39	•	•
		3,8	4		54	22	•	•
					75	43	•	•
		3,9	4		54	22	•	•
					75	43	•	•
		3,97	4		54	22	•	•
					75	43	•	•
4	4	54	22	•	•			
		75	43	•	•			
4,1	6	66	22	36	•	•		
		87	43		•	•		
4,2	6	66	22		•	•		
		87	43		•	•		
4,3	6	68	24		•	•		
		91	47		•	•		
4,37	6	68	24		•	•		
		91	47		•	•		
4,4	6	68	24		•	•		
		91	47		•	•		
4,5	6	68	24		•	•		
		91	47		•	•		
4,6	6	68	24		•	•		
		91	47		•	•		
4,65	6	68	24		•	•		
		91	47		•	•		
4,7	6	68	24		•	•		
		91	47		•	•		
4,76	6	70	26		•	•		
		96	52		•	•		
4,8	6	70	26		•	•		
		96	52		•	•		
4,9	6	70	26		•	•		
		96	52		•	•		
5	6	70	26		•	•		
		96	52		•	•		
5,1	6	70	26		•	•		
		96	52		•	•		
5,16	6	70	26	•	•			
		96	52	•	•			
5,2	6	70	26	•	•			
		96	52	•	•			
5,3	6	70	26	•	•			
		96	52	•	•			
5,4	6	72	28	•	•			
		101	57	•	•			
5,5	6	72	28	•	•			
		101	57	•	•			
5,55	6	72	28	•	•			
		101	57	•	•			
5,56	6	72	28	•	•			
		101	57	•	•			



универсальное применение

Система обозначений	
d1	диаметр режущей части, мм
Лобц	общая длина, мм
l2	длина рабочей части, мм
dxв	диаметр хвостовика, мм
lxв	длина хвостовика, мм

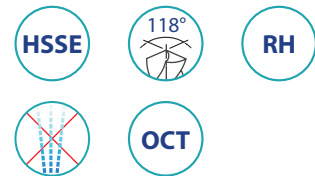
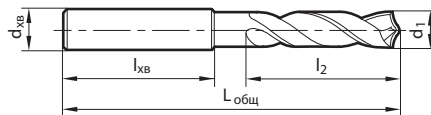

сверла
HSSE, HSSE



Глубина обработки		3xD	5xD				
Материал		HSSE-PM	HSSE-PM				
Покрытие		TiAIN	TiAIN				
Группы обрабатываемых материалов	P	•	•				
	M	•	•				
	N	•	•				
	K	•	•				
	S	•	•				
Основное применение		H					
d1	dxв	Лобц	l2	lxв	Артикулы		
						STD2231	STD2251
5,56	6	101	57	36		•	
5,6		72	28		•		
		101	57			•	
5,7		72	28		•		
		101	57			•	
5,8		72	28		•		
		101	57			•	
5,9		72	28		•		
		101	57			•	
5,95		72	28		•		
		101	57			•	
6		72	28		•		
		101	57			•	
6,1		75	31		•		
		107	63			•	
6,2		75	31		•		
		107	63			•	
6,3		75	31		•		
	107	63		•			
6,35	75	31	•				
	107	63		•			
6,4	75	31	•				
	107	63		•			
6,5	75	31	•				
	107	63		•			
6,6	75	31	•				
	107	63		•			
6,7	75	31	•				
	107	63		•			
6,75	78	34	•				
	113	69		•			
6,8	78	34	•				

6,8	8	113	69	36		•
		78	34		•	
6,9		113	69			•
		78	34		•	
7		113	69			•
		78	34		•	
7,1		113	69			•
		78	34		•	
7,14		113	69			•
		78	34		•	
7,2		113	69			•
		78	34		•	
7,3		113	69			•
		78	34		•	
7,4		113	69			•
		78	34		•	
7,5		113	69			•
		78	34		•	
7,54	113	69		•		
	81	37	•			
7,55	119	75		•		
	81	37	•			
7,6	119	75		•		
	81	37	•			
7,7	119	75		•		
	81	37	•			
7,8	119	75		•		
	81	37	•			
7,9	119	75		•		
	81	37	•			
7,94	119	75		•		
	81	37	•			
8	119	75		•		
	87	37	•			
8,1	125	75		•		
	87	37	•			
8,2	125	75		•		
	87	37	•			
8,3	125	75		•		
	87	37	•			
8,33	125	75		•		
	87	37	•			
8,4	125	75		•		
	87	37	•			
8,5	125	75		•		
	91	40	•			
8,6	131	81		•		
	91	40	•			
8,7	131	81		•		
	91	40	•			
8,73	131	81		•		
	91	40	•			
8,8	131	81		•		
	91	40	•			
8,9	131	81		•		
	91	40	•			
9	131	81		•		
	91	40	•			
9,1	91	40	•			

универсальное применение

сверла
HSS, HSSE

Система обозначений	
d1	диаметр режущей части, мм
Лобщ	общая длина, мм
l2	длина рабочей части, мм
dxв	диаметр хвостовика, мм
lxв	длина хвостовика, мм

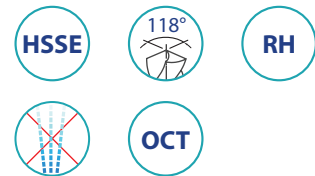
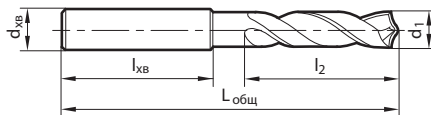

Глубина обработки		3xD	5xD				
Материал		HSSE-PM	HSSE-PM				
Покрытие							
Группы обрабатываемых материалов	P	•	•				
	M	•	•				
	N	•	•				
	K	•	•				
	S	•	•				
Основное применение		H					
d1	dxв	Лобщ	l2	lxв	Артикулы		
						STD2231	STD2251
9,1	10	131	81	40	•	•	
9,13		91	40		•		
		131	81			•	
9,2		91	40		•		
		131	81			•	
9,3		91	40		•		
		131	81			•	
9,4		91	40		•		
		131	81			•	
9,5		91	40		•		
		131	81			•	
9,52		93	43		•		
		137	87			•	
9,55		93	43		•		
		137	87			•	
9,6		93	43		•		
		137	87			•	
9,7		93	43		•		
		137	87			•	
9,8		93	43		•		
	137	87		•			
9,9	93	43	•				
	137	87		•			
9,92	93	43	•				
	137	87		•			
10	93	43	•				
	137	87		•			
10,1	100	43	•				
	144	87		•			
10,2	100	43	•				
	144	87		•			
10,3	100	43	•				
	144	87		•			

10,32	12	100	43	45	•	
		144	87			•
10,4		100	43		•	
		144	87			•
10,5		100	43		•	
		144	87			•
10,6		100	43		•	
		144	87			•
10,7		104	47		•	
		151	94			•
10,72		104	47		•	
		151	94			•
10,8		104	47		•	
		151	94			•
10,9		104	47		•	
		151	94			•
11		104	47		•	
		151	94			•
11,1		104	47		•	
		151	94			•
11,11	104	47	•			
	151	94		•		
11,2	104	47	•			
	151	94		•		
11,3	104	47	•			
	151	94		•		
11,4	104	47	•			
	151	94		•		
11,5	104	47	•			
	151	94		•		
11,51	104	47	•			
	151	94		•		
11,6	104	47	•			
	151	94		•		
11,7	104	47	•			
	151	94		•		
11,8	104	47	•			
	151	94		•		
11,9	108	51	•			
	158	101		•		
11,91	108	51	•			
	158	101		•		
12	108	51	•			
	158	101		•		
12,1	111	51	•			
	161	101		•		
12,2	111	51	•			
	161	101		•		
12,3	111	51	•			
	161	101		•		
12,4	111	51	•			
	161	101		•		
12,5	111	51	•			
	161	101		•		
12,6	111	51	•			
	161	101		•		
12,7	111	51	•			
	161	101		•		

универсальное применение

Система обозначений	
d1	диаметр режущей части, мм
Лобц	общая длина, мм
l2	длина рабочей части, мм
dxв	диаметр хвостовика, мм
lxв	длина хвостовика, мм

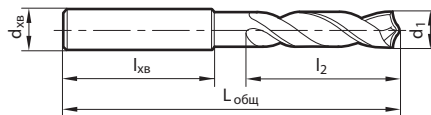

сверла
HSS, HSSE



Глубина обработки		3xD	5xD			
Материал		HSSE-PM	HSSE-PM			
Покрытие		TiAIN	TiAIN			
Группы обрабатываемых материалов	P	•	•			
	M	•	•			
	N	•	•			
	K	•	•			
	S	•	•			
Основное применение						
	H					
d1	dxв	Лобц	l2	lxв	Артикулы	
					STD2231	STD2251
12,8	16	111	51	48	•	
		161	101			•
12,9	16	111	51	48	•	
		161	101			•
13	16	111	51	48	•	
		161	101			•
13,1	16	111	51	48	•	
		161	101			•
13,49	16	114	54	48	•	
		166	106			•
13,5	16	114	54	48	•	
		166	106			•
13,89	16	114	54	48	•	
		166	106			•
14	16	114	54	48	•	
		166	106			•
14,29	16	116	56	48	•	
		169	109			•
14,5	16	116	56	48	•	
		169	109			•
15	16	116	56	48	•	
		169	109			•
15,5	16	118	58	48	•	
		172	112			•
15,87	16	118	58	48	•	
		172	112			•
16	16	118	58	48	•	
		172	112			•

16,5	20	126	60	50	•	
		181	115			•
16,67	20	126	60	50	•	
		181	115			•
17	20	126	60	50	•	
		181	115			•
17,46	20	184	118	50		•
		128	62		•	
17,5	20	184	118	50		•
		128	62		•	
18	20	184	118	50		•
		130	64		•	
18,5	20	188	122	50		•
		130	64		•	
19	20	188	122	50		•
		132	66		•	
19,5	20	191	125	50		•
		132	66		•	
20	20	191	125	50		•

универсальное применение

сверла
HSS, HSSE

Система обозначений	
d	диаметр ступеней, мм
Лобц	общая длина, мм
dхв	диаметр хвостовика, мм

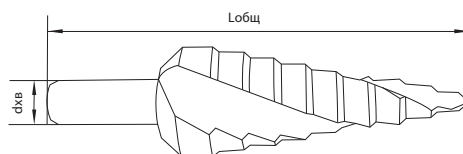

HSS

HSSE



Материал			HSS	HSS	HSS	HSSE
Покрытие			(BR)	(TiN)	(TiAlN)	(BR)
Группы обрабатываемых материалов Основное применение	P		•	•	•	•
	M			○	•	•
	N		•	•	•	•
	K		•	•	•	•
d	Лобц	dхв	Артикулы			
			STSD9620	STSD9621	STSD9622	STSD9615
4, 5, 6, 7, 8, 9, 10, 11, 12	80	6	4-12	4-12	4-12	
4, 6, 8, 10, 12, 14, 16, 18, 20	67	8	4-20	4-20	4-20	
6, 8, 10, 12, 14, 16, 18, 20, 22, 24, 26, 28, 30	98	10	6-30	6-30	6-30	
6, 9, 12, 15, 18, 21, 24, 27, 30, 33, 36	82	12	6-36	6-36	6-36	
4, 5, 6, 7, 8, 9, 10, 11, 12	65	6				4-12
4, 6, 8, 10, 12, 14, 16, 18, 20	75	8				4-20
6, 8, 10, 12, 14, 16, 18, 20, 22, 24, 26, 28, 30	100	10				6-30
6, 9, 13, 16, 19, 21, 23, 26, 29, 32, 35, 38	100	10				6-38
НАБОРЫ			STSD9620SET	STSD9621SET	STSD9622SET	
4-12; 4-20; 6-30			4-30	4-30	4-30	

Пример заказа:

Для заказа ступенчатого сверла с покрытием TiN с диаметрами 4-12 мм: STSD9621 d4-12

СВЕРЛА С КОНУСОМ МОРЗЕ



универсальное применение

Система обозначений	
d1	диаметр режущей части, мм
Лобц	общая длина, мм
l2	длина рабочей части, мм
МК	конус Морзе

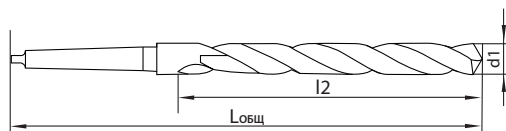

сверла
конус Морзе



Глубина обработки		5xD	5xD	5xD	10xD	10xD		
Материал		HSS	HSSE	HSSE	HSS	HSSE		
Покрытие								
Угол при вершине		118°	130°	118°	118°	118°		
Группы обрабатываемых материалов Основное применение	P	•	○	•	•	•		
	M	•	•	○	•	•		
	N	○	○	○	○	•		
	K	•	•	•	•	•		
	S	•	○	•	•	○		
	H							
d1	МК	Лобц	l2	Артикулы				
				STD1020	STD7224	STD2020	STD2134	STD1234
3,00	1	114,0	33,0	•				
3,30	1	117,0	36,0	•				
3,60	1	120,0	39,0	•				
3,75	1			•				
4,00	1	124,0	43,0	•				
	1	145,0	64,0				•	
4,20	1	124,0	43,0	•			•	
	1	145,0	64,0					
4,25	1	124,0	43,0	•				
4,50	1	128,0	47,0	•				
4,80	1	133,0	52,0	•				
4,90	1			•				
5,00	1			•	•	•		
5,10	1	155,0	74,0				•	•
	1	133,0	52,0	•				
5,20	1	155,0	74,0				•	
	1	133,0	52,0	•				
5,30	1	133,0	52,0	•				
5,50	1	138,0	57,0	•	•			
	1	161,0	80,0				•	
5,70	1	138,0	57,0	•				
	1	161,0	80,0	•			•	
6,00	1	138,0	57,0	•	•	•		
	1	161,0	80,0				•	•
6,10	1	144,0	63,0	•				
6,20	1			•				
6,40	1			•				
6,50	1			•	•			
6,60	1			•				
6,70	1			•				
6,75	1	150,0	69,0	•				
	1			•				
6,80	1	174,0	93,0				•	
	1							

универсальное применение

Система обозначений	
d1	диаметр режущей части, мм
Лобц	общая длина, мм
l2	длина рабочей части, мм
МК	конус Морзе

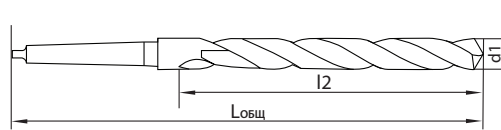

сверла конус Морзе

Глубина обработки	5xD	5xD	5xD	5xD	5xD	10xD	10xD	10xD	10xD			
Материал	HSS	HSS	HSSE	HSSE	HSSE	HSS	HSS	HSSE	HSSE			
Покрытие	V	TIN	BR	V	TIN	BR	V	BR	V			
Угол при вершине	118°	118°	130°	118°	118°	118°	118°	130°	118°			
Группы обрабатываемых материалов Основное применение	P	•	•	○	•	○	•	•	•			
	M	•	•	•	○	•	•	○	•			
	N	○	○	○	○	○	○	○	•			
	K	•	•	•	•	•	•	•	•			
	S	•	•	○	•	○	•	•	○			
H												
d1	МК	Лобц	l2	Артикулы								
				STD1020	STD2124	STD7224	STD2020	STD2224	STD1134	STD2134	STD7234	STD1234
6,90	1	150,0	69,0	•								
7,00	1		93,0	•		•						
7,20	1	150,0	69,0	•								
7,25	1			•								
7,30	1			•								
7,40	1			•								
7,50	1			•			•					
7,60	1	156,0	75,0	•								
7,70	1			•								
7,75	1			•								
7,80	1			181,0	100,0						•	
7,90	1	156,0	75,0	•								
8,00	1			100,0	•	•	•	•				
8,10	1	156,0	75,0	•					•	•	*	
8,20	1			100,0	•							
8,25	1	156,0	75,0	•								
8,30	1			•								
8,40	1			•								
8,50	1			181,0	100,0	•	•	•	•			•
8,60	1	162,0	81,0	•								
8,70	1			•								
8,75	1			•								
8,80	1			•								
8,90	1			•								
9,00	1	188,0	107,0	•	•	•	•		•	•	*	
	1											



С КОНУСОМ МОРЗЕ 5-10xD ИЗ БЫСТРОРЕЖУЩЕЙ СТАЛИ HSS, HSSE

универсальное применение

Система обозначений	
d1	диаметр режущей части, мм
Лобц	общая длина, мм
l2	длина рабочей части, мм
МК	конус Морзе

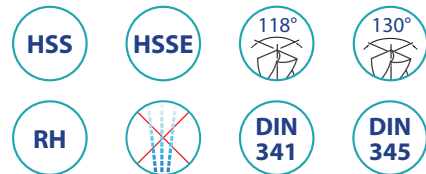
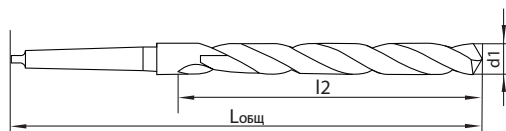

Глубина обработки	5xD	5xD	5xD	5xD	5xD	10xD	10xD	10xD	10xD			
Материал	HSS	HSS	HSSE	HSSE	HSSE	HSS	HSS	HSSE	HSSE			
Покрытие	V	TIN	BR	V	TIN	BR	V	BR	V			
Угол при вершине	118°	118°	130°	118°	118°	118°	118°	130°	118°			
Группы обрабатываемых материалов Основное применение	P	•	•	○	•	○	•	•	•			
	M	•	•	•	○	•	•	○	•			
	N	○	○	○	○	○	○	○	•			
	K	•	•	•	•	•	•	•	•			
	S	•	•	○	•	○	•	•	○			
H												
d1	МК	Лобц	l2	Артикулы								
				STD1020	STD2124	STD7224	STD2020	STD2224	STD1134	STD2134	STD7234	STD1234
9,10	1	162,0	81,0	•								
9,20	1			•								
9,25	1			•								
9,30	1			•								
9,40	1			•								
9,50	1	188,0	107,0	•	•	•	•				*	
9,60	1			•								
9,70	1	168,0	87,0	•								
9,75	1			•								
9,80	1			•								
9,90	1			•								
10,00	1	168,0	87,0	•	•	•	•	•				
	1	197,0	116,0	•					•	•		•
10,10	1	168,0	87,0	•								
10,20	1			•						•	•	*
10,25	1	168,0	87,0	•	•		•					
10,30	1			•								
10,40	1			•								
10,50	1			•			•	•			•	•
10,60	1	168,0	87,0	•								
10,70	1	175,0	94,0	•								
10,75	1			•	•							
10,80	1			•								
10,90	1			•								
11,00	1			•	•	•	•	•			•	•
	1	206,0	125,0						•	•	*	

универсальное применение

Система обозначений	
d1	диаметр режущей части, мм
Лобц	общая длина, мм
l2	длина рабочей части, мм
МК	конус Морзе

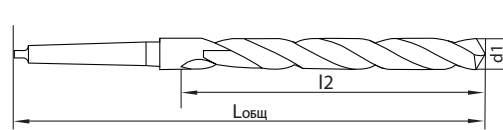

сверла конус Морзе

Глубина обработки		5xD	5xD	5xD	5xD	5xD	10xD	10xD	10xD	10xD			
Материал		HSS	HSS	HSSE	HSSE	HSSE	HSS	HSS	HSSE	HSSE			
Покрытие		V	TIN	BR	V	TIN	BR	V	BR	V			
Угол при вершине		118°	118°	130°	118°	118°	118°	118°	130°	118°			
Группы обрабатываемых материалов Основное применение	P	•	•	○	•	○	•	•	•	•			
	M			•	○	•			○	•			
	N	○	○	○	○	○	○	○	•	•			
	K	•	•		•	•	•	•	•	•			
	S			○		○			○	○			
	H												
d1	МК	Лобц	l2	Артикулы									
				STD1020	STD2124	STD7224	STD2020	STD2224	STD1134	STD2134	STD7234	STD1234	
11,10	1	175,0	94,0	•									
11,20	1			•			•						
11,25	1			•	•								
11,30	1			•									
11,40	1			•									
11,50	1	206,0	125,0	•	•		•			•		•	
11,60	1	175,0	94,0	•									
11,70	1			•									
11,75	1			•									
11,80	1	206,0	125,0	•						•	•		
11,90	1			•									
12,00	1	182,0	101,0	•	•	•	•	•					
12,00	1	215,0	134,0						•	•	*	•	
12,10	1	182,0	101,0	•									
12,20	1			•			•						
12,25	1			•			•						
12,30	1			•									
12,40	1			•									
12,50	1			•			•	•	•				
12,50	1	215,0	134,0						•		*		
12,60	1	182,0	101,0	•									
12,70	1			•									
12,75	1			•			•						
12,80	1			•									
12,90	1			•									
12,90	1			•									
13,00	1	215,0	134,0	•	•	•	•	•					
13,00	1			•						•	•	*	•
13,10	1	182,0	101,0	•									
13,20	1	182,0	101,0	•									

универсальное применение

Система обозначений	
d1	диаметр режущей части, мм
Лобц	общая длина, мм
l2	длина рабочей части, мм
МК	конус Морзе

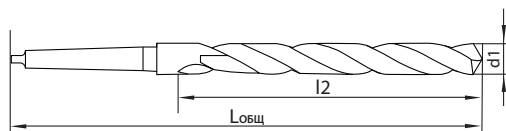

Глубина обработки	5xD	5xD	5xD	5xD	5xD	10xD	10xD	10xD	10xD						
Материал	HSS	HSS	HSSE	HSSE	HSSE	HSS	HSS	HSSE	HSSE						
Покрытие	V	TIN	BR	V	TIN	BR	V	BR	V						
Угол при вершине	118°	118°	130°	118°	118°	118°	118°	130°	118°						
Группы обрабатываемых материалов Основное применение	P	•	•	○	•	○	•	•	•						
	M	•	•	•	○	•	•	○	•						
	N	○	○	○	○	○	○	○	•						
	K	•	•	•	•	•	•	•	•						
	S	•	•	○	•	○	•	•	○						
H															
d1	МК	Лобц	l2	Артикулы											
				STD1020	STD2124	STD7224	STD2020	STD2224	STD1134	STD2134	STD7234	STD1234			
13,25	1	189,0	108,0	•	•										
13,30	1			•											
13,40	1			•											
13,49	1			•											
13,50	1			•											
13,50	1	223,0	142,0		•				•						
13,60	1	189,0	108,0	•											
13,70	1			•											
13,75	1			•											
13,75	1			223,0	142,0						•				
13,80	1			189,0	108,0	•									
13,90	1	•													
14,00	1	•													
14,00	1	223,0	142,0				•				•				
14,10	2	212,0	114,0			•									
14,20	2			•											
14,25	2			•											
14,29	2			•											
14,30	2			•											
14,50	2			245,0	147,0		•				•				
14,50	2			212,0	114,0	•									
14,60	2					•									
14,75	2					•									
15,00	2					•									
15,00	2	245,0	147,0								•				
15,20	2	218,0	120,0	•											
15,25	2			•											
15,50	2			•											
15,50	2			251,0	153,0						•				
15,75	2			218,0	120,0	•									
15,75	2	251,0	153,0												
15,80	2	218,0	120,0	•											
16,00	2			•											
16,00	2	251,0	153,0		•					•					

универсальное применение

Система обозначений	
d1	диаметр режущей части, мм
Лобц	общая длина, мм
l2	длина рабочей части, мм
МК	конус Морзе

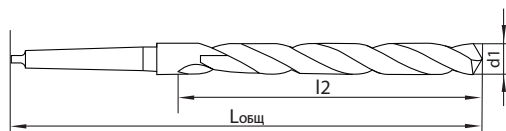

сверла конус Морзе

Глубина обработки	5xD	5xD	5xD	5xD	10xD	10xD	10xD	10xD			
Материал	HSS	HSS	HSSE	HSSE	HSS	HSS	HSSE	HSSE			
Покрытие	V	TIN	BR	V	BR	V	BR	V			
Угол при вершине	118°	118°	130°	118°	118°	118°	130°	118°			
Группы обрабатываемых материалов Основное применение	P	•	•	○	•	•	•	•			
	M			•	○		○	•			
	N	○	○	○	○	○	○	•			
	K	•	•	•	•	•	•	•			
	S			○				○			
	H										
d1	МК	Лобц	l2	Артикулы							
				STD1020	STD2124	STD7224	STD2020	STD1134	STD2134	STD7234	STD1234
16,10	2	223,0	125,0	•							
16,20	2			•							
16,25	2			•			•				
16,40	2	257,0	159,0					•	•		
16,50	2	223,0	125,0	•	•		•				
	2	257,0	159,0						•	*	
16,75	2	223,0	125,0	•			•				
17,00	2			•	•		•				
17,25	2	257,0	159,0	•				•	•		
	2			•	•		•			*	
17,46	2	228,0	130,0	•			•				
17,50	2			•	•		•				
17,50	2	263,0	165,0	•				•	•	*	•
	2			•	•		•				
17,75	2	228,0	130,0	•			•				
18,00	2			•	•		•				
18,00	2	263,0	165,0	•				•	•	*	•
	2			•	•		•				
18,20	2	233,0	135,0	•			•				
18,25	2			•	•		•				
18,50	2	269,0	171,0	•	•		•			*	
	2			•	•		•				
18,75	2	233,0	135,0	•				•			
	2			•	•		•				
19,00	2	269,0	171,0	•	•		•				
	2			•	•		•			•	*
19,05	2	238,0	140,0				•				
19,25	2			•	•		•				
19,50	2	238,0	140,0	•	•		•				
	2			•	•		•			•	*
19,70	2	238,0	140,0	•							
19,75	2			•	•		•				
20,00	2	275,0	177,0	•	•		•				
	2			•	•		•			•	*

универсальное применение

Система обозначений	
d1	диаметр режущей части, мм
Лобц	общая длина, мм
l2	длина рабочей части, мм
МК	конус Морзе

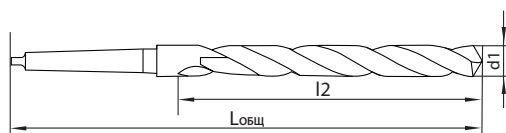

сверла конус Морзе



Глубина обработки	5xD	5xD	5xD	5xD	5xD	10xD	10xD	10xD			
Материал	HSS	HSS	HSSE	HSSE	HSSE	HSS	HSS	HSSE			
Покрытие	V	TIN	BR	V	TIN	BR	V	V			
Угол при вершине	118°	118°	130°	118°	118°	118°	118°	118°			
Группы обрабатываемых материалов Основное применение	P	•	•	○	•	○	•	•			
	M	•	•	•	○	•	•	•			
	N	○	○	○	○	○	○	•			
	K	•	•	•	•	•	•	•			
	S	•	•	○	•	○	•	○			
H											
d1	МК	Лобц	l2	Артикулы							
				STD1020	STD2124	STD7224	STD2020	STD2224	STD1134	STD2134	STD1234
20,10	2	243,0	145,0	•							
20,20	2			•							
20,25	2			•			•				
20,40	2			•							
20,50	2	282,0	184,0	•	•						
20,75	2			•			•		•		
21,00	2	243,0	145,0	•	•						
21,00	2			•					•		
21,25	2	248,0	150,0	•							
21,40	2	282,0	184,0	•						•	
21,50	2	248,0	150,0	•		•					
21,50	2	289,0	191,0						•		
21,75	2	248,0	150,0	•							
22,00	2			•	•						
22,00	2	289,0	191,0							•	
22,10	2	248,0	150,0	•							
22,20	2			•							
22,25	2			•							
22,50	2	253,0	198,0	•	•	•					
22,50	2	296,0		•				•	•	•	
22,75	2	253,0	155,0	•							
23,00	2			•	•		•			•	•
23,00	2	296,0	198,0							•	
23,25	3	276,0	155,0	•							
23,25	3	319,0	198,0					•	•		
23,50	3	276,0	155,0	•		•					
23,50	3	319,0	198,0						•	•	
23,75	3	281,0	160,0	•							
24,00	3			•	•		•				
24,00	3	327,0	206,0						•	•	

универсальное применение

Система обозначений	
d1	диаметр режущей части, мм
Лобц	общая длина, мм
l2	длина рабочей части, мм
МК	конус Морзе

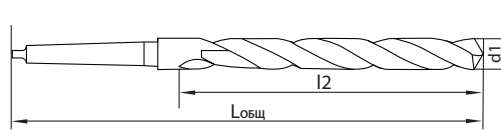

сверла конус Морзе

Глубина обработки		5xD	5xD	5xD	5xD	10xD	10xD	10xD		
Материал		HSS	HSS	HSSE	HSSE	HSS	HSS	HSSE		
Покрытие		V	TiN	BR	V	BR	V	V		
Угол при вершине		118°	118°	130°	118°	118°	118°	118°		
Группы обрабатываемых материалов Основное применение	P	•	•	○	•	•	•	•		
	M			•	○			•		
	N	○	○	○	○	○	○	•		
	K	•	•		•	•	•	•		
	S			○				○		
H										
d1	МК	Лобц	l2	Артикулы						
				STD1020	STD2124	STD7224	STD2020	STD1134	STD2134	STD1234
24,25	3			•						
24,30	3	281,0	160,0	•						
24,50	3	327,0	206,0	•	•					
24,75	3	281,0	160,0	•						
25,00	3	327,0	206,0	•	•					
25,20	3			•						
25,25	3	286,0	165,0	•						
25,40	3			•						
25,50	3	335,0	214,0	•	•					
25,75	3			•						
25,80	3	286,0	165,0	•						
26,00	3	335,0	214,0	•	•					
26,25	3	286,0	165,0	•						
26,50	3	335,0	214,0	•	•					
26,75	3			•						
27,00	3	291,0	170,0	•	•					
27,25	3	343,0	222,0	•						
27,50	3	291,0	170,0	•						
27,75	3	343,0	222,0	•						
28,00	3	291,0	170,0	•						
28,25	3	343,0	222,0	•	•					
28,50	3			•						
28,57	3	296,0	175,0	•						
28,75	3			•						
29,00	3	351,0	230,0	•	•					

универсальное применение

Система обозначений	
d1	диаметр режущей части, мм
Лобц	общая длина, мм
l2	длина рабочей части, мм
МК	конус Морзе

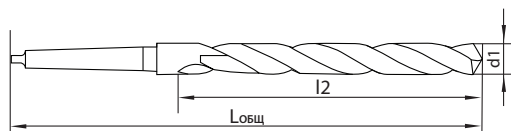

сверла конус Морзе



Глубина обработки	5xD	5xD	5xD	5xD	10xD	10xD			
Материал	HSS	HSS	HSSE	HSSE	HSS	HSS			
Покрытие									
Угол при вершине	118°	118°	130°	118°	118°	118°			
Группы обрабатываемых материалов Основное применение	P	•	•	○	•	•			
	M	•	•	○	•	•			
	N	○	○	○	○	○			
	K	•	•	•	•	•			
	S	•	•	○	•	•			
H									
d1	МК	Лобц	l2	Артикулы					
				STD1020	STD2124	STD7224	STD2020	STD1134	STD2134
29,25	3			•					
29,50	3	296,0	175,0	•	•	•	•		
	3	351,0	230,0					•	•
29,75	3			•					
	3	296,0	175,0	•	•	•	•		
30,00	3							•	•
	3	351,0	230,0						
30,25	3			•					
30,50	3			•		•			
30,60	3	301,0	180,0	•					
30,75	3			•					
	3			•					
31,00	3					•	•		
	3	360,0	239,0					•	•
31,25	3			•					
31,50	3	301,0	180,0	•		•	•		
31,75	3	306,0	185,0	•					
	4	334,0	185,0	•		•	•		
32,00	4							•	•
	4	397,0	248,0						
32,50	4			•		•			
	4	334,0	185,0	•			•		
33,00	4			•		•	•		
	4	397,0	248,0					•	•
33,50	4	334,0	185,0	•		•			
34,00	4			•		•	•		
	4	339,0	190,0	•					
	4	406,0	257,0					•	•
34,50	4			•					
	4	339,0	190,0	•		•	•		
35,00	4			•					
	4	406,0	257,0					•	•
35,50	4	339,0	190,0	•		•	•		
	4	344,0	195,0	•		•	•		
36,00	4			•		•		•	•
	4	416,0	267,0						
36,50	4			•		•			
	4	344,0	195,0	•		•		•	•
37,00	4			•		•			
	4	416,0	267,0						
37,50	4	344,0	195,0	•					

универсальное применение

Система обозначений	
d1	диаметр режущей части, мм
Лобц	общая длина, мм
l2	длина рабочей части, мм
МК	конус Морзе

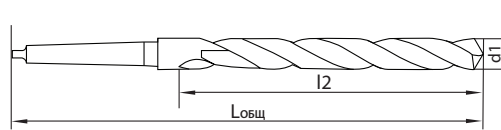

сверла конус Морзе

Глубина обработки		5xD	5xD	5xD	10xD	10xD		
Материал		HSS	HSSE	HSSE	HSS	HSS		
Покрытие		V	BR	V	BR	V		
Угол при вершине		118°	130°	118°	118°	118°		
Группы обрабатываемых материалов Основное применение	P	•	○	•	•	•		
	M		•	○				
	N	○	○	○	○	○		
	K	•	•	•	•	•		
	S		○					
	H							
d1	МК	Лобц	l2	Артикулы				
				STD1020	STD7224	STD2020	STD1134	STD2134
38,00	4	349,0	200,0	•	•	•		
	4	426,0	277,0					
38,50	4			•	•			
	4	349,0	200,0	•	•			
39,00	4	426,0	277,0				•	
	4	349,0	200,0	•				
39,50	4	426,0	277,0				•	•
	4	349,0	200,0	•	•	•		
40,00	4	426,0	277,0				•	•
	4	349,0	200,0	•	•	•		
40,50	4			•				
	4	354,0	205,0	•	•			
41,00	4	436,0	287,0					•
	4	354,0	205,0	•	•			
41,50	4			•				
	4	436,0	287,0	•	•			
42,00	4	436,0	287,0				•	•
	4	354,0	205,0	•	•			
42,50	4	354,0	205,0	•	•			
	4	359,0	210,0	•	•			
43,00	4	447,0	298,0					•
	4	359,0	210,0	•	•			
43,50	4			•				
	4	447,0	298,0	•	•		•	•
44,00	4	359,0	210,0	•	•			
	4	359,0	210,0	•	•			
44,50	4	447,0	298,0				•	
	4	359,0	210,0	•	•			
45,00	4	447,0	298,0				•	
	4			•				
45,50	4			•	•			
	4	364,0	215,0	•	•			
46,00	4			•				
	4	364,0	215,0	•	•			
46,50	4			•				
	4	364,0	215,0	•	•			
47,00	4			•				
	4	369,0	220,0	•	•			
47,50	4	369,0	220,0	•	•			
	4	470,0	321,0				•	•
48,00	4	369,0	220,0	•	•			
	4	470,0	321,0				•	•
48,50	4	369,0	220,0	•	•			
	4	470,0	321,0				•	•
49,00	4	369,0	220,0	•	•			
	4	470,0	321,0				•	•

универсальное применение

Система обозначений	
d1	диаметр режущей части, мм
Лобц	общая длина, мм
l2	длина рабочей части, мм
МК	конус Морзе

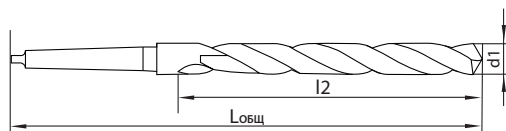

Глубина обработки	5xD	5xD	5xD	10xD	10xD			
Материал	HSS	HSSE	HSSE	HSS	HSS			
Покрытие								
Угол при вершине	118°	130°	118°	118°	118°			
Группы обрабатываемых материалов Основное применение	P	•	○	•	•			
	M	•	•	•	•			
	N	○	○	○	○			
	K	•	•	•	•			
	S	•	○	•	•			
H								
d1	МК	Лобц	l2	Артикулы				
				STD1020	STD7224	STD2020	STD1134	STD2134
49,50	4	369,0	220,0	•				
50,00	4		220,0	•				
50,00	4	470,0	321,0				•	•
50,50	4	374,0	225,0	•				
50,80	4			225,0	•			
51,00	5	412,0	225,0	•				
52,00	5			225,0	•			
53,00	5	417,0	230,0	•				
54,00	5			230,0	•			•
55,00	5	422,0	235,0	•				
56,00	5			235,0	•			
56,50	5	427,0	240,0	•				
57,00	5			240,0	•			
58,00	5	432,0	245,0	•				
59,00	5			245,0	•			
60,00	5	437,0	250,0	•				
61,00	5			250,0	•			
62,00	5	442,0	255,0	•				
63,00	5			255,0	•			
64,00	5	432,0	245,0	•				
65,00	5			245,0	•			
66,00	5	437,0	250,0	•				
67,00	5			250,0	•			
68,00	5	442,0	255,0	•				
69,00	5			255,0	•			
70,00	5	432,0	245,0	•				
71,00	5			245,0	•			
72,00	5	437,0	250,0	•				
73,00	5			250,0	•			
74,00	5	442,0	255,0	•				
75,00	5			255,0	•			

универсальное применение

Система обозначений	
d1	диаметр режущей части, мм
Лобц	общая длина, мм
l2	длина рабочей части, мм
МК	конус Морзе

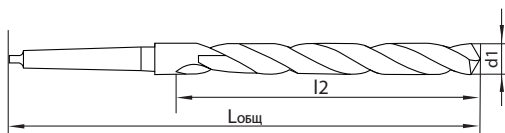

Глубина обработки		5xD		
Материал		HSS		
Покрытие		V		
Угол при вершине		118°		
Группы обрабатываемых материалов Основное применение	P	•		
	M			
	N	o		
	K	•		
	S			
	H			
d1	МК	Лобц	l2	Артикулы
STD1020				
76,00	5	447,0	260,0	•
77,00	6	514,0		•
78,00	6			•
79,00	6			•
80,00	6		519,0	265,0
81,00	6	•		
82,00	6	•		
83,00	6	•		
84,00	6	•		
85,00	6	524,0		
86,00	6		•	
87,00	6		•	
88,00	6		•	
89,00	6		•	
90,00	6			•

сверла конус Морзе

универсальное применение

Система обозначений	
d1	диаметр режущей части, мм
Лобц	общая длина, мм
l2	длина рабочей части, мм
МК	конус Морзе

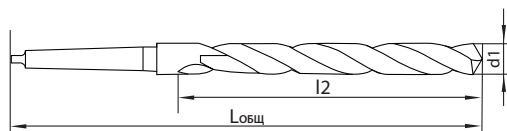

Глубина обработки				~15xD	~15xD	~15xD	~15xD	~15xD	~20xD	~20xD	~20xD	~23xD	
Материал				HSS	HSS	HSS	HSSE	HSSE	HSS	HSS	HSS	HSS	
Покрытие				BR	V	Nit	BR	Nit	BR	V	Nit	Nit	
Угол при вершине				118°	118°	130°	130°	130°	118°	118°	130°	130°	
Группы обрабатываемых материалов Основное применение				P	•	•	•	•	•	•	•	•	
				M				○	•				
				N	○	○	•	•	•	○	○	•	•
				K	•	•	•	•	•	•	•	•	•
				S				○	•				
H								○					
d1	МК	Лобц	l2	Артикулы									
				STD1144	STD2144	STD3144	STD7244	STD3244	STD1154	STD2154	STD3154	STD2164	
8,00	1	265,0	165,0	•		•							
	1	330,0	210,0								•		
	1	500,0	420,0									•	
8,50	1	265,0	165,0	•	•	•							
	1	330,0	210,0							•	•		
	1	500,0	420,0									•	
9,00	1	275,0	175,0	•	•	•							
	1	345,0	220,0							•			
	1	500,0	420,0										
9,50	1	275,0	175,0		•								
	1	345,0	220,0							•	•		
10,00	1	285,0	185,0	•	•	•	•	•					
	1	360,0	235,0						•	•	•		
	1	500,0	420,0									•	
10,20	1	285,0	185,0		•								
10,50	1	285,0	185,0			•							
	1	360,0	235,0						•	•	•		
11,00	1	300,0	195,0	•	•	•							
	1	375,0	250,0							•	•		
11,50	1	300,0	195,0			•							
11,80	1	300,0	195,0		•								
	1	310,0	205,0	•		•							
	1	395,0	260,0						•		•		
12,00	1	500,0	420,0										
	1	310,0	205,0		•	•		•					
	1	395,0	260,0								•		
12,50	1	310,0	205,0			•							
	1	395,0	260,0										
13,00	1	310,0	205,0	•	•	•							
	1	395,0	260,0						•	•	•		
	1	500,0	420,0									•	
13,50	1	325,0	220,0	•		•		•					
	1	410,0	275,0							•	•		

универсальное применение

Система обозначений	
d1	диаметр режущей части, мм
Лобц	общая длина, мм
l2	длина рабочей части, мм
МК	конус Морзе

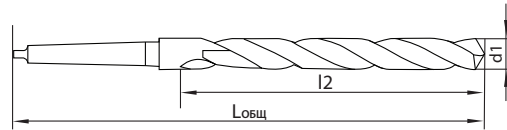

сверла конус Морзе

Глубина обработки		~15xD	~15xD	~15xD	~15xD	~15xD	~20xD	~20xD	~20xD	~23xD	~25xD	~35xD	~47xD		
Материал		HSS	HSS	HSS	HSSE	HSSE	HSS	HSS	HSS	HSS	HSS	HSS	HSS		
Покрытие		BR	V	Nit	BR	Nit	BR	V	Nit	Nit	Nit	BR	BR		
Угол при вершине		118°	118°	130°	130°	130°	118°	118°	130°	130°	130°	130°	130°		
Группы обрабатываемых материалов Основное применение	P	•	•	•	•	•	•	•	•	•	•	•	•		
	M	•	•	•	•	•	•	•	•	•	•	•	•		
	N	○	○	•	•	•	○	○	•	•	•	•	•		
	K	•	•	•	•	•	•	•	•	•	•	•	•		
	S	•	•	•	○	•	•	•	•	•	•	•	•		
	H	•	•	•	•	○	•	•	•	•	•	•	•		
d1	МК	Лобц	l2	Артикулы											
				STD1144	STD2144	STD3144	STD7244	STD3244	STD1154	STD2154	STD3154	STD2164	STD1174	STD1184	STD1194
14,00	1	325,0	220,0	•	•	•	•	•							
	1	410,0	275,0						•	•					
	1	500,0	420,0								•				
	1	600,0	500,0										•		
	1	750,0	650,0											•	
14,50	2	340,0	220,0	•	•	•									
	2	425,0	275,0						•	•	•				
15,00	2	340,0	220,0	•	•	•	•	•							
	2	500,0	400,0								•				
	2	600,0	500,0									•			
	2	750,0	650,0										•		
	2	1000,0	850,0											•	
15,50	2	355,0	230,0	•		•									
	2	445,0	295,0						•	•	•				
15,75	2	355,0	230,0		•										
15,80	2	355,0	230,0		•										
16,00	2	355,0	230,0	•	•	•	•	•							
	2	445,0	295,0						•	•	•		•		
	2	500,0	400,0								•		•		
	2	600,0	500,0									•	•		
16,25	2	750,0	650,0										•		
	2	355,0	230,0		•										
	2	355,0	230,0	•		•		•							
16,50	2	445,0	295,0						•		•				
	2	355,0	230,0	•	•	•		•							
17,00	2	355,0	230,0	•	•	•		•							
	2	445,0	295,0						•		•				
	2	500,0	400,0								•				
17,50	2	370,0	245,0	•	•	•									
	2	465,0	310,0						•		•				
17,75	2	370,0	245,0		•										

универсальное применение

Система обозначений	
d1	диаметр режущей части, мм
Лобц	общая длина, мм
l2	длина рабочей части, мм
МК	конус Морзе

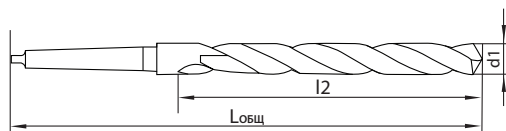

Глубина обработки		~15xD	~15xD	~15xD	~15xD	~15xD	~20xD	~20xD	~20xD	~23xD	~25xD	~35xD	~47xD		
Материал		HSS	HSS	HSS	HSSE	HSSE	HSS	HSS	HSS	HSS	HSS	HSS	HSS		
Покрытие		BR	V	Nit	BR	Nit	BR	V	Nit	Nit	Nit	BR	BR		
Угол при вершине		118°	118°	130°	130°	130°	118°	118°	130°	130°	130°	130°	130°		
Группы обрабатываемых материалов Основное применение	P	•	•	•	•	•	•	•	•	•	•	•	•		
	M	•	•	•	•	•	•	•	•	•	•	•	•		
	N	•	•	•	•	•	•	•	•	•	•	•	•		
	K	•	•	•	•	•	•	•	•	•	•	•	•		
	S	•	•	•	•	•	•	•	•	•	•	•	•		
	H	•	•	•	•	•	•	•	•	•	•	•	•		
d1	МК	Лобц	l2	Артикулы											
				STD1144	STD2144	STD3144	STD7244	STD3244	STD1154	STD2154	STD3154	STD2164	STD1174	STD1184	STD1194
18,00	2	370,0	245,0	•	•	•		•							
	2	465,0	310,0						•	•	•				
	2	500,0	400,0									•			
	2	600,0	500,0										•		
	2	750,0	650,0											•	
18,50	2	1000,0	850,0												•
	2	370,0	245,0	•	•										
19,00	2	465,0	310,0						•	•	•				
	2	370,0	245,0	•	•	•	•	•							
	2	500,0	400,0									•			
19,50	2	600,0	500,0										•		
	2	385,0	260,0	•		•									
	2	490,0	325,0								•			•	
20,00	2	385,0	260,0	•	•	•		•							
	2	490,0	325,0						•	•	•				
	2	600,0	500,0									•		•	
20,50	2	385,0	260,0	•		•									
	2	490,0	325,0						•	•	•				
21,00	2	385,0	260,0	•	•	•									
	2	490,0	325,0						•	•	•				
	2	600,0	500,0										•		
22,00	2	405,0	270,0	•	•	•									
	2	515,0	345,0						•	•	•				
	2	600,0	500,0										•		
22,50	2	405,0	270,0	•	•										
	2	515,0	345,0						•						
23,00	2	405,0	270,0	•		•									
	2	515,0	345,0						•	•	•				
	2	600,0	500,0										•		
23,50	3	425,0	270,0	•	•										
	3	535,0	345,0						•					•	

универсальное применение

Система обозначений	
d1	диаметр режущей части, мм
Лобц	общая длина, мм
l2	длина рабочей части, мм
МК	конус Морзе

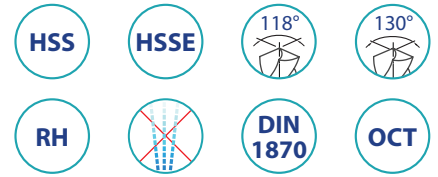
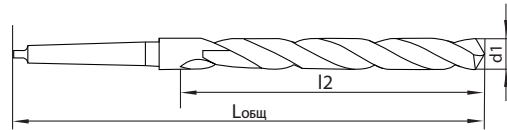

сверла конус Морзе

Глубина обработки				~15xD	~15xD	~15xD	~20xD	~20xD	~20xD	~25xD
Материал				HSS	HSS	HSS	HSS	HSS	HSS	HSS
Покрытие				BR	V	Nit	BR	V	Nit	Nit
Угол при вершине				118°	118°	130°	118°	118°	130°	130°
Группы обрабатываемых материалов Основное применение	P			•	•	•	•	•	•	•
	M									
	N			○	○	•	○	○	•	•
	K			•	•	•	•	•	•	•
	S									
	H									
d1	МК	Лобц	l2	Артикулы						
				STD1144	STD2144	STD3144	STD1154	STD2154	STD3154	STD1174
24,00	3	440,0	290,0	•	•	•				
	3	555,0	365,0				•		•	
	3	600,0	475,0							•
24,50	3	440,0	290,0	•	•					
	3	555,0	365,0				•			•
	3	440,0	290,0	•	•					
25,00	3	555,0	365,0	•			•		•	
	3	600,0	475,0							•
	3	440,0	290,0	•						
25,50	3	555,0	365,0	•			•			
	3	440,0	290,0	•						
	3	555,0	365,0				•		•	
26,00	3	440,0	290,0	•	•	•				
	3	555,0	365,0				•			•
	3	440,0	290,0	•	•					
26,50	3	440,0	290,0	•	•					
	3	460,0	305,0	•						
	3	580,0	385,0				•			
28,00	3	460,0	305,0	•		•				
	3	580,0	385,0							•
	3	460,0	305,0	•						
28,50	3	460,0	305,0	•						
	3	460,0	305,0	•		•				
	3	580,0	385,0				•			•
29,00	3	460,0	305,0	•		•				
	3	580,0	385,0				•			•
	3	460,0	305,0	•	•	•				
30,00	3	580,0	385,0				•		•	
	3	600,0	475,0							•
	3	480,0	320,0	•	•					
30,50	3	480,0	320,0	•						
	3	480,0	320,0				•			
	3	610,0	410,0							•
31,00	4	505,0	320,0	•						
	4	635,0	410,0				•			
	4	600,0	450,0				•			
33,00	4	505,0	320,0	•	•					
	4	635,0	410,0				•			
	4	530,0	340,0	•						
34,00	4	530,0	340,0	•						
	4	530,0	340,0	•						
	4	665,0	430,0				•			

универсальное применение

Система обозначений	
d1	диаметр режущей части, мм
Лобц	общая длина, мм
l2	длина рабочей части, мм
МК	конус Морзе

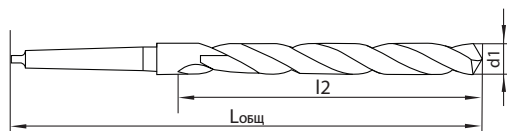

сверла
конус Морзе



Глубина обработки		~15xD	~20xD	~20xD		
Материал		HSS	HSS	HSS		
Покрытие		BR	BR	V		
Угол при вершине		118°	118°	118°		
Группы обрабатываемых материалов Основное применение	P	•	•	•		
	M					
	N	o	o	o		
	K	•	•	•		
	S					
	H					
d1	МК	Лобц	l2	Артикулы		
				STD1144	STD1154	STD2154
36,00	4	530,0	340,0	•		
	4	416,0	267,0		•	
37,00	4	530,0	340,0	•		
	4	416,0	267,0		•	
38,00	4	555,0	360,0	•		
	4	695,0	460,0		•	
	4	600,0	450,0		•	
39,00	4	555,0	360,0	•		
	4	695,0	460,0		•	
40,00	4	555,0	360,0	•		
	4	695,0	460,0		•	
41,00	4	695,0	460,0		•	
	4	555,0	360,0	•		
42,00	4	695,0	460,0		•	
	4	555,0	360,0	•		
43,00	4	585,0	385,0	•		
	4	585,0	385,0		•	
44,00	4	585,0	385,0	•		
	4	735,0			•	
45,00	4	585,0	385,0	•		
	4	735,0			•	
47,00	4	585,0	385,0	•		
48,00	4	605,0	405,0	•		
49,00	4	765,0	510,0			•
50,00	4	605,0	405,0	•		
	4	765,0	510,0		•	

ЦЕНТРОВОЧНЫЕ СВЕРЛА ЗЕНКОВКИ



Центровые
сверла
зенковки

STAMO

STAMO

STAMO

HSS, HSSE

DIN 333

ОСТ

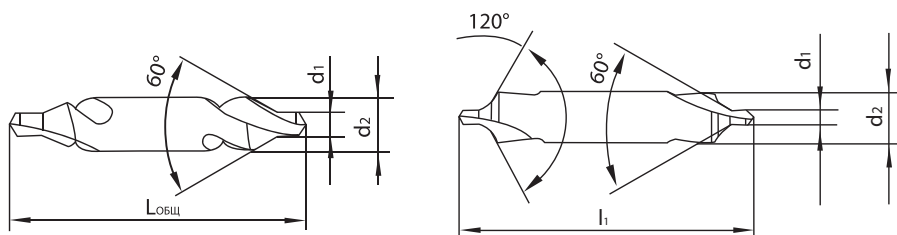

Система обозначений

d1	диаметр режущей части, мм
d2	диаметр хвостовика, мм
Lобщ	общая длина, мм
L2	длина рабочей части

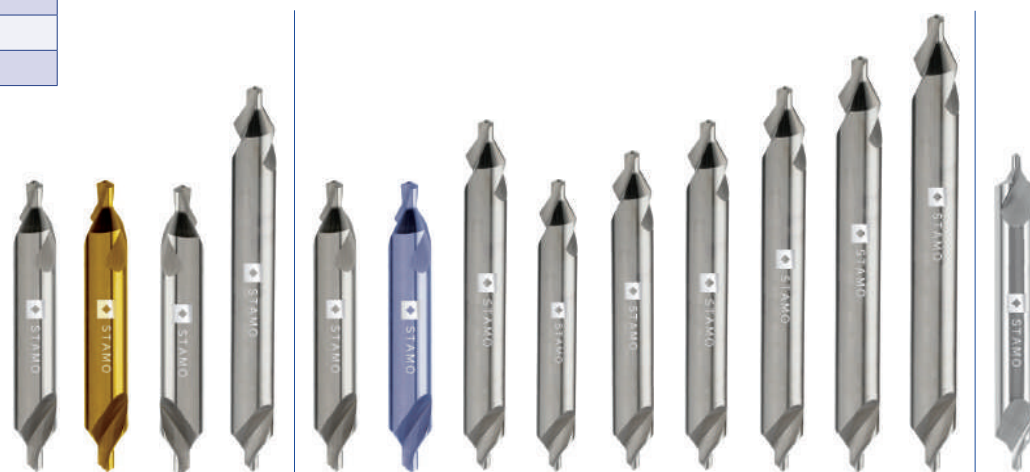

Материал	HSS	HSS	HSS	HSS	HSSE	HSSE	HSSE	HSSE	HSSE	HSSE	HSSE	HSSE	HSSE	HSS
Покрyтие	BR	TIN	BR	BR	BR	TiAlN	BR	BR	BR	BR	BR	BR	BR	BR
Точность хвостовика	h7, h8	h8	h8	h8	h8	h8	h7	h7	h7	h7	h7	h7	h7	h8
Форма	A	A	A	A	A	A	A	A	A	A	A	A	A	B
Угол	60°	60°	60°	60°	60°	60°	60°	60°	60°	60°	60°	60°	60°	60°/120°
Направление	правое	правое	левое	правое	правое	правое	правое	правое	правое	правое	правое	правое	правое	правое
Группы обрабатываемых материалов. Основное применение	P	•	•	•	•	•	•	•	•	•	•	•	•	•
	M	o	o	o	o	o	o	o	o	o	o	o	o	o
	N	•	•	•	•	•	•	•	•	•	•	•	•	•
	K	•	•	•	•	•	•	•	•	•	•	•	•	•
	S	•	•	•	•	•	•	•	•	•	•	•	•	•
d1 мм	L общ.	d2 h8 мм	L2	Артикулы										
STC8110 STC8111 STC8112 STC8130 STC8210 STC8310 STC8212 STC8213 STC8214 STC8215 STC8216 STC8217 STC8218 STC8132														
0,5	25	3,15	0,6-0,9	•	•	•								
	31,5													
0,75	60	3,5	1-1,3						•					
	120													
0,8	25	3,15	1-1,3	•	•	•								
	31,5													
1,0	31,5	4	1,3-1,7	•	•	•		•	•					•
	35													
	60									•				
	100											•		
	120												•	
1,25	31,5	3,15	1,6-2	•	•	•		•	•					
	40													
1,5	60	5	2-2,6						•					
	100													
	150												•	
1,6	35,5	4,0	2-2,6	•	•	•		•	•					
	45	6,3												
	120	5,0												
2,0	40	5,0	2,5-3,1	•	•	•		•	•					
	50	8												
	80													
	100													
	120													
	150													
2,5	200	5	3,1-3,8											•
	45	6,3		•	•	•		•	•					
	55	11												
	80													
	100													
	120													

HSS, HSSE

DIN 333

ОСТ

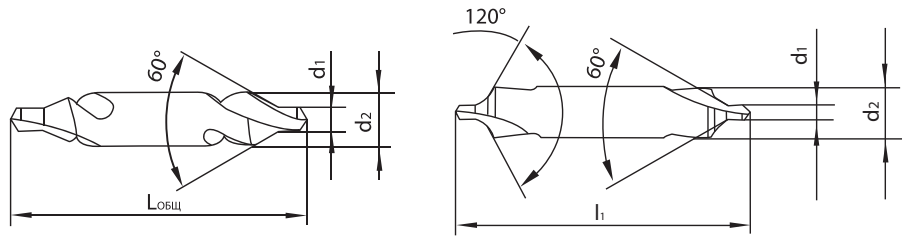

Система обозначений

d1	диаметр режущей части, мм
d2	диаметр хвостовика, мм
Lобщ	общая длина, мм
L2	длина рабочей части

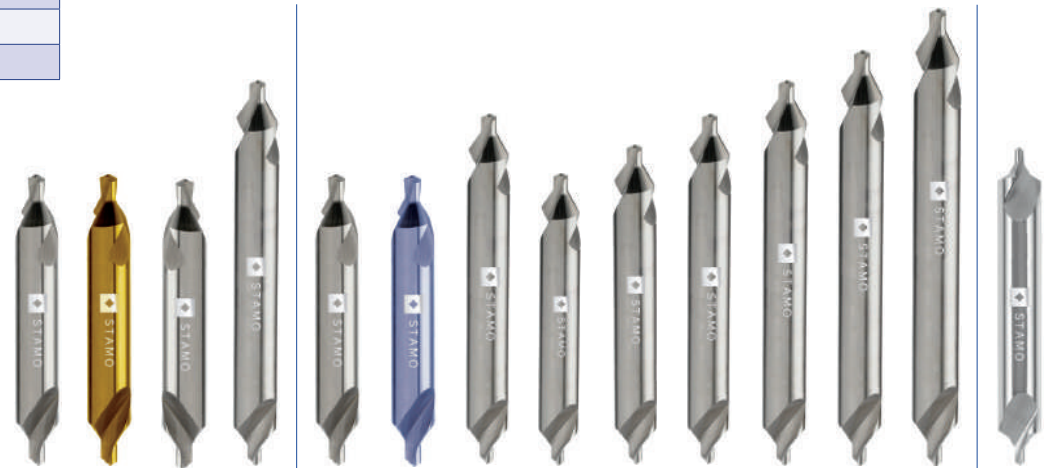

Центровые сверла зенковки

Материал	HSS	HSS	HSS	HSS	HSSE	HSSE	HSSE	HSSE	HSSE	HSSE	HSSE	HSSE	HSSE	HSS
Покрyтие	BR	TiN	BR	BR	BR	TiAlN	BR	BR	BR	BR	BR	BR	BR	BR
Точность хвостовика	h7, h8	h8	h8	h8	h8	h8	h7	h7	h7	h7	h7	h7	h7	h8
Форма	A	A	A	A	A	A	A	A	A	A	A	A	A	B
Угол	60°	60°	60°	60°	60°	60°	60°	60°	60°	60°	60°	60°	60°	60°/120°
Направление	правое	правое	левое	правое	правое	правое	правое	правое	правое	правое	правое	правое	правое	правое
Группы обрабатываемых материалов. Основное применение	P	•	•	•	•	•	•	•	•	•	•	•	•	•
	M	o	o	o	o	o	o	o	o	o	o	o	o	o
	N	•	•	•	•	•	•	•	•	•	•	•	•	•
	K	•	•	•	•	•	•	•	•	•	•	•	•	•
	S	•	•	•	•	•	•	•	•	•	•	•	•	•
d1 мм	L общ.	d2 h8 мм	I2	Артикулы										
STC8110 STC8111 STC8112 STC8130 STC8210 STC8310 STC8212 STC8213 STC8214 STC8215 STC8216 STC8217 STC8218 STC8132														
3,0	80	8	3,9-4,6											
	100	8												
	150	10												
3,15	50	8,0	3,9-4,6	•	•	•	•	•	•	•	•	•	•	•
	62	11,2												
	120	10												
	200	8												
4,0	56	10,0	5,0-5,9	•	•	•	•	•	•	•	•	•	•	•
	63	10												
	71	16	5-5,9											
	100	10												
	120	12												
	150	10												
5,0	200	10	5-5,9											
	63	12,5												
	71	16	6,3-7,2	•	•	•	•	•	•	•	•	•	•	•
	100	12												
6,3	120	14	8-8,9											
	71	16,0												
8	80	20	10,1-11,1	•	•	•	•	•	•	•	•	•	•	•
	100	25												
10	80	20,0	12,8-13,8	•	•	•	•	•	•	•	•	•	•	•
	100	25,0												
12,5	125	31,5		•	•	•	•	•	•	•	•	•	•	•
	125	31,5												

VHM

DIN 333

ОСТ

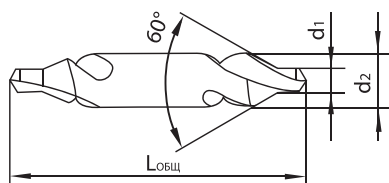

Система обозначений	
d1	диаметр режущей части, мм
d2	диаметр хвостовика, мм
Лобщ	общая длина, мм
L2	длина рабочей части



центровые сверла из твердого сплава

Материал	VHM		VHM	VHM		
Покрытие	BR		BR	TiAlN		
Точность хвостовика	h7		h8	h8		
Форма	A		A	A		
Угол	60°		60°	60°		
Направление	правое		правое	правое		
Группы обрабатываемых материалов. Основное применение	P	•	•	•		
	M	•	•	•		
	N	•	•	•		
	K	•	•	•		
	S	○	○	•		
	H	○	○	○		
d1 мм	L общ.	d2 h8 мм	l2	Артикулы		
				STC8410	STC8411	STC8412
0,5	25	3,15	0,6-0,9		•	
	31,5			•	•	
0,8	25	3,15	1-1,3		•	
	31,5			•	•	
1,0	31,5	3,15	1,3-1,7	•		•
1,25			1,6-2	•	•	
1,6	35,5	4,0	2-2,6	•		•
2,0	40	5,0	2,5-3,1	•		•
2,5	45	6,3	3,1-3,8	•		•
3,15	50	8,0	3,9-4,6	•		•
4,0	56	10,0	5,0-5,9	•		•
5,0	63	12,5	6,3-7,2	•		•
6,3	71	16,0	8-8,9	•		•

HSS, HSSE

DIN 333

ОСТ

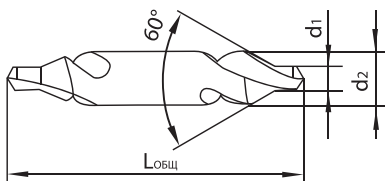

Система обозначений	
d1	диаметр режущей части, мм
d2	диаметр хвостовика, мм
Лобщ	общая длина, мм
L2	длина рабочей части



Материал	HSS		HSS	HSS		
Покрyтие	BR		TiN	BR		
Точность хвостовика	h8		h8	h8		
Форма	R		R	R		
Угол	60°		60°	60°		
Направление	правое		правое	левое		
Группы обрабатываемых материалов. Основное применение	P	•	•	•		
	M	○	○	○		
	N	•	•	•		
	K	•	•	•		
	S	○	○	○		
	H					
d1 мм	L общ.	d2 h8 мм	I2	Артикулы		
				STC8510	STC8511	STC8512
0,5	25	3,15	2,3-2,9	•	•	
0,8	25		2,6-2,9	•	•	
1,0	31,5		3-3,3	•	•	•
1,25	31,5		3,3-3,6	•	•	•
1,6	35,5	4,0	4,2-4,7	•	•	•
2,0	40	5,0	5-5,4	•	•	•
2,5	45	6,3	6,3-6,8	•	•	
3,15	50	8,0	8-8,5	•	•	•
4,0	56	10,0	10,0-10,6	•	•	•
5,0	63	12,5	12,5-13,1	•		
6,3	71	16,0	16-16,6	•		
8	80	20,0	20-20,7	•		
10	100	25,0	25-25,7	•		
12,5	125	31,5	31,5-32,3	•		

РЕЖИМЫ РЕЗАНИЯ. ЦЕНТРОВОЧНЫЕ СВЕРЛА ДВУХСТОРОННИЕ

Двухсторонние центровочные сверла из быстрорежущей стали

Группы обрабатываемых материалов	Vc м/мин	центровочные сверла из HSS, HSSE				
		f мм/об.	f мм/об.	f мм/об.	f мм/об.	
		d0,5 - d1,25	d1,6 - d2,5	d3,15 - d5	d6,3 - d8	
P	стали <500 Н/мм ²	30-45	0,020-0,030	0,030-0,050	0,050-0,080	0,080-0,110
	стали <700 Н/мм ²	30-40	0,020-0,030	0,030-0,050	0,050-0,080	0,080-0,110
	стали <850 Н/мм ²	25-35	0,020-0,030	0,030-0,050	0,050-0,080	0,080-0,110
	стали <1000 Н/мм ²	10-20	0,010-0,020	0,020-0,030	0,030-0,040	0,050-0,070
	стали <1400 Н/мм ²	5-10	0,010-0,020	0,020-0,030	0,030-0,040	0,050-0,070
	цементируемые стали <1000 Н/мм ²	15-25	0,010-0,020	0,020-0,030	0,030-0,040	0,050-0,070
	азотированные стали <1000 Н/мм ²	10-15	0,010-0,020	0,020-0,030	0,030-0,040	0,050-0,070
	термообрабатываемые стали	15-20	0,010-0,020	0,020-0,030	0,030-0,040	0,050-0,070
	инструментальные стали	7-12	0,010-0,020	0,020-0,030	0,030-0,040	0,050-0,070
M	нержавеющие и кислотостойкие стали <700 Н/мм ²	10-15	0,010	0,020	0,020-0,050	0,050-0,060
	нержавеющие и кислотостойкие стали >700 Н/мм ²	10-15	0,010	0,020	0,020-0,050	0,050-0,060
K	серый чугун <180 HB	20-30	0,020-0,030	0,030-0,050	0,050-0,080	0,080-0,110
	ковкий чугун	20-30	0,020-0,030	0,030-0,040	0,040-0,060	0,060-0,090
N	Al и Al сплавы <6% Si	60-80	0,020-0,030	0,030-0,050	0,050-0,080	0,080-0,110
	Al и Al сплавы <12% Si	40-60	0,020-0,030	0,030-0,050	0,050-0,080	0,080-0,110
	бронза, медь, латунь	40-80	0,020-0,030	0,030-0,050	0,050-0,080	0,080-0,110
	термо и дюропластики	15-40	0,020-0,030	0,040-0,050	0,050-0,090	0,090-0,100
S	титан, сплавы титана	3-8	0,010	0,010-0,020	0,020-0,030	0,030-0,040

Двухсторонние центровочные сверла из VHM

Группы обрабатываемых материалов	Vc м/мин	центровочные сверла из VHM				
		f мм/об.	f мм/об.	f мм/об.	f мм/об.	
		d0,5 - d1,25	d1,6 - d2,5	d3,15 - d4	d5 - d6,3	
P	стали <500 Н/мм ²	80	0,020-0,030	0,080-0,100	0,100-0,130	0,130-0,200
	стали <700 Н/мм ²	80	0,020-0,030	0,080-0,100	0,100-0,130	0,130-0,200
	стали <850 Н/мм ²	75	0,020-0,030	0,080	0,080-0,100	0,100-0,150
	стали <1000 Н/мм ²	70	0,020-0,030	0,080	0,080-0,100	0,100-0,150
	стали <1400 Н/мм ²	35	0,010-0,020	0,060-0,080	0,080-0,100	0,100-0,150
	цементируемые стали <1000 Н/мм ²	65	0,010-0,020	0,060-0,080	0,080-0,100	0,100-0,150
	азотированные стали <1000 Н/мм ²	65	0,010-0,020	0,060-0,080	0,080-0,100	0,100-0,150
	термообрабатываемые стали	65	0,010-0,020	0,060-0,080	0,080-0,100	0,100-0,150
	инструментальные стали	40	0,010-0,020	0,060-0,080	0,080-0,100	0,100-0,150
M	нержавеющие и кислотостойкие стали <700 Н/мм ²	30	0,010	0,020	0,020-0,030	0,030-0,070
	нержавеющие и кислотостойкие стали >700 Н/мм ²	25	0,010	0,020	0,020-0,030	0,030-0,070
K	серый чугун <180 HB	70	0,040	0,070-0,080	0,080-0,130	0,130-0,180
	ковкий чугун	70	0,020	0,060-0,080	0,080-0,100	0,100-0,150
	чугун с шаровидным графитом	70	0,020	0,060-0,080	0,080-0,100	0,100-0,150
N	Al и Al сплавы <6% Si	200	0,010	0,020	0,020-0,030	0,030-0,070
	Al и Al сплавы <12% Si	180	0,010	0,020	0,020-0,030	0,030-0,070
	Al и Al сплавы >12% Si	160	0,010	0,020	0,020-0,030	0,030-0,070
	бронза, медь, латунь	100	0,010	0,010	0,010-0,020	0,020-0,060
	термо и дюропластики	45	0,010	0,050	0,050	0,100-0,140
S	титан, сплавы титана	25	0,010-0,020	0,020	0,020-0,030	0,030-0,070

HSS, HSSE

h6 90°

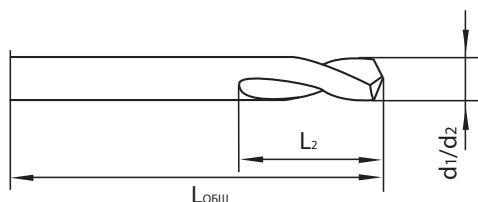

Система обозначений	
d1	диаметр режущей части, мм
d2	диаметр хвостовика, мм
Лобщ	общая длина, мм
L2	длина рабочей части

HSS

HSSE

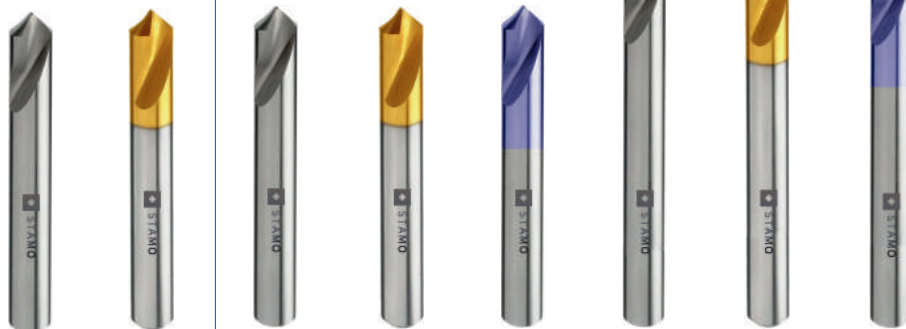

Центровые сверла
зенковки

Угол при вершине	90°	90°	90°	90°	90°	90°	90°	90°
Материал	HSS	HSS	HSSE	HSSE	HSSE	HSSE	HSSE	HSSE
Тип						XL	XL	XL
Хвостовик	HA	HA	HA	HA	HA	HA	HA	HA
Покрытие	BR	TIN	BR	TIN	TAIN	BR	TIN	TAIN
Группы обрабатываемых материалов. Основное применение	P	•	•	•	•	•	•	•
	M	○	○	○	○	○	○	○
	N	•	•	•	•	•	•	•
	K	•	•	•	•	•	•	•
	S	○	○	○	○	○	○	○
H								

d1/d2 мм	Лобщ	L2 мм	Артикулы							
			STD9190	STD9191	STD9294	STD9293	STD9295	STD9292	STD9296	STD9297
3	46	12	•	•	•	•				
	50	10								
	80						•	•		
4	52	12								
	55		•	•	•	•				
	100							•	•	
5	60	15			•	•				
	62	14	•	•						
	120	15						•	•	
6	66	16	•	•						
	66	20			•	•				
	140						•	•		
8	79	21	•	•						
	79	25			•	•	•			
	140						•	•	•	
10	89	25	•	•	•	•	•			
	170							•	•	•
12	102	30	•	•	•	•	•			
	170							•	•	•
14	107	33,5	•							
16	115	35			•	•	•			
	115	37,5	•	•						
	200	35						•	•	
20	131	40			•	•	•			
	131	45	•	•						
	200	40						•	•	
25	138	45				•				
	151	53	•	•						

HSS, HSSE

h6 120°

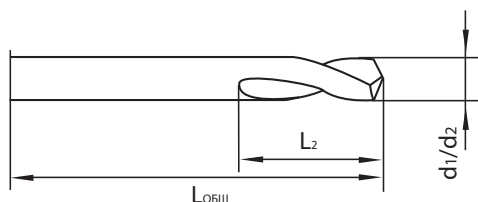

Система обозначений	
d1	диаметр режущей части, мм
d2	диаметр хвостовика, мм
Лобщ	общая длина, мм
L2	длина рабочей части

центровые сверла
из быстрорежущей стали



Угол при вершине	120°	120°	120°	120°	120°	120°	120°	120°		
Материал	HSS	HSS	HSSE	HSSE	HSSE	HSSE	HSSE	HSSE		
Тип						XL	XL	XL		
Хвостовик	HA	HA	HA	HA	HA	HA	HA	HA		
Покрытие	BR	TIN	BR	TIN	TiAlN	BR	TIN	TiAlN		
Группы обрабатываемых материалов. Основное применение	P	•	•	•	•	•	•	•		
	M	○	○	○	○	○	○	○		
	N	•	•	•	•	•	•	•		
	K	•	•	•	•	•	•	•		
	S	○	○	○	•	•	○	•		
H										
d1/d2 мм	Лобщ	L2 мм	Артикулы							
			STD9113	STD9112	STD9212	STD9114	STD9115	STD9116	STD9117	STD9118
3	46	12	•	•		•				
	50	10			•			•	•	
	80									
4	52	12			•					
	55		•	•	•					
	100							•	•	
5	60	15			•	•				
	62	14	•	•						
	120	15						•	•	
6	66	16	•	•						
	66	20			•	•				
	140							•	•	
8	79	21	•	•						
	79	25			•	•	•			
	140							•	•	•
10	89	25	•	•		•	•			
	170							•	•	•
12	102	30	•	•		•	•			
	170							•	•	•
14	107	33,5	•							
	115	35			•	•	•			
16	115	37,5	•	•						
	200	35						•	•	•
20	131	40			•	•	•			
	131	45	•	•						
	200	40						•	•	•
25	151	53	•	•						

VHM

h6

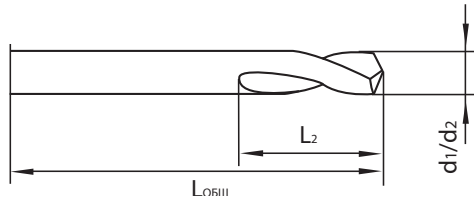

Система обозначений	
d1	диаметр режущей части, мм
d2	диаметр хвостовика, мм
Лобщ	общая длина, мм
L2	длина рабочей части

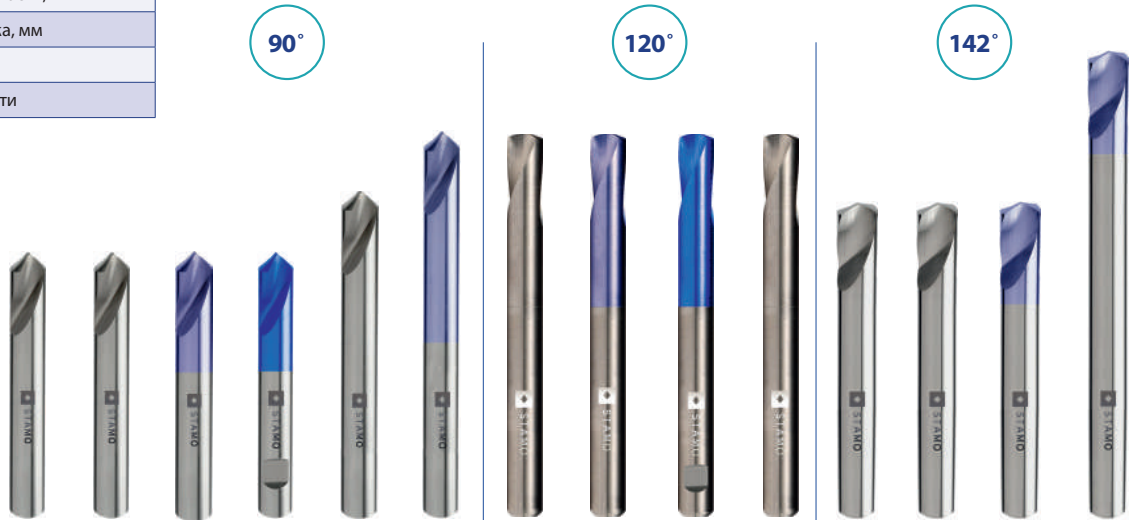

Центровые сверла зенковки

Угол при вершине	90°	90°	90°	90°	90°	90°	120°	120°	120°	120°	142°	142°	142°	142°
Материал	VHM	VHM	VHM	VHM	VHM	VHM	VHM	VHM	VHM	VHM	VHM	VHM	VHM	VHM
Тип					XL	XXL								XXL
Хвостовик	HA	HA	HA	HB	HA	HA	HA	HA	HB	HA	HA	HB	HA	HA
Покрытие	(BR)	(BR)	(TiAlN)	(STB)	(BR)	(TiAlN)	(BR)	(TiAlN)	(STB)	(BR)	(BR)	(BR)	(TiAlN)	(TiAlN)
Группы обрабатываемых материалов. Основное применение	P	•	•	•	•	•	•	•	•	•	•	•	•	•
	M	○	○	•	•	○	•	○	•	•	○	○	○	•
	N	•	•	•	•	•	•	•	•	•	•	•	•	•
	K	•	•	•	•	•	•	•	•	•	•	•	•	•
	S	○	○	•	•	○	•	○	•	•	○	○	○	•
H	○	○	○	○	○	○	○	○	○	○	○	○	○	○

d1/d2 мм	Лобщ	L2 мм	Артикулы													
			STD9491	STD9490	STD9493	STD9494	STD9495	STD9496	STD9413	STD9415	STD9416	STD9412	STD9417	STD9414	STD9418	STD9419
1	26	3	•		•											
	32	6	•		•											
2	38	8							•	•			•		•	
	32	8	•		•											
	38	8	•		•											
	46	12														
3	100	15					•									
	40	10	•		•				•	•			•		•	
	50	11														
	55	12		•									•			
4	100	15					•									
	4/6	120	10					•								•
	50	13	•		•				•	•			•		•	
5	62	14		•								•		•		
	100	20					•									
	5/6	132	13					•								•
6	50	13	•		•				•	•			•		•	
	57	13														
	66	16		•				•				•		•		
	139	15						•								•
8	60	16	•		•				•	•			•		•	
	23															
	63	19											•		•	
	79	21		•								•		•		
	100	25					•									
10	165	17						•								•
	66	20														
	70	20	•		•				•	•	•					
	24												•		•	
	89	25		•								•		•		
	100	25					•									
184	20						•								•	

ЦЕНТРОВОЧНЫЕ СВЕРЛА ДЛЯ СТАНКОВ ЧПУ 90°, 120°, 142° ТВЕРДОСПЛАВНЫЕ

VHM

h6

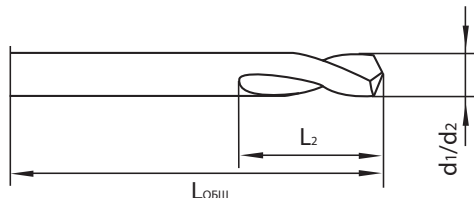

Система обозначений	
d1	диаметр режущей части, мм
d2	диаметр хвостовика, мм
Лобщ	общая длина, мм
L2	длина рабочей части

90°

120°

142°

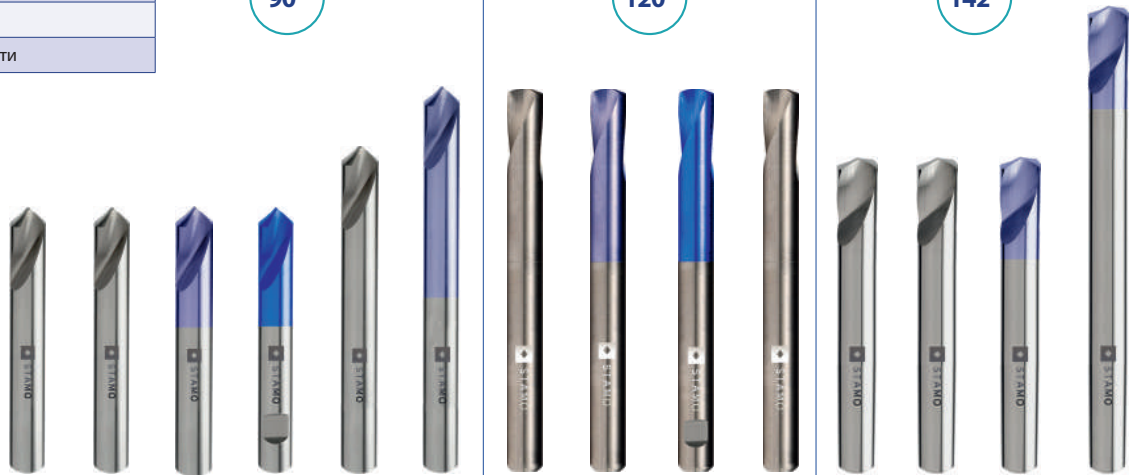

Угол при вершине	90°	90°	90°	90°	90°	90°	120°	120°	120°	120°	142°	142°	142°	142°
Материал	VHM	VHM	VHM	VHM	VHM	VHM	VHM	VHM	VHM	VHM	VHM	VHM	VHM	VHM
Тип					XL	XXL								XXL
Хвостовик	HA	HA	HA	HB	HA	HA	HA	HA	HB	HA	HA	HB	HA	HA
Покрытие	(BR)	(BR)	(TiAlN)	(STB)	(BR)	(TiAlN)	(BR)	(TiAlN)	(STB)	(BR)	(BR)	(BR)	(TiAlN)	(TiAlN)
Группы обрабатываемых материалов. Основное применение	P	•	•	•	•	•	•	•	•	•	•	•	•	•
	M	○	○	•	•	○	•	○	•	•	○	○	○	•
	N	•	•	•	•	•	•	•	•	•	•	•	•	•
	K	•	•	•	•	•	•	•	•	•	•	•	•	•
	S	○	○	•	•	○	•	○	•	•	○	○	○	•
	H	○	○	○	○	○	○	○	○	○	○	○	○	○
d1/d2 мм	Лобщ	L2 мм	Артикулы											
STD9491 STD9490 STD9493 STD9494 STD9495 STD9496 STD9413 STD9415 STD9416 STD9412 STD9417 STD9414 STD9418 STD9419														
12	70	24	•	•	•		•	•	•		•		•	
	73	22												
	102	30		•							•		•	
	150	25				•								
	205	25						•						•
14	75	26												
	75	26												
16	75	28	•		•		•	•	•				•	
	82	24												
	115	37,5		•						•		•		
	230	30						•						•
18	100	33												
	100	35	•		•	•								
20	92	30												
	100	33												
	100	35	•		•	•							•	•
	131	45		•							•		•	•

Центровочные сверла ЧПУ из быстрорежущей стали

Группы обрабатываемых материалов	Vc м/мин	центровочные сверла без покрытия					Vc м/мин	центровочные сверла с покрытием			
		f мм/об.	f мм/об.	f мм/об.	f мм/об.	f мм/об.		f мм/об.	f мм/об.	f мм/об.	
		d2 - d4	d4 - d6	d6 - d10	d10 - d16	d2 - d4		d4 - d6	d6 - d10	d10 - d20	
P	стали <500 Н/мм ²	35-45	0,040-0,050	0,050-0,080	0,080-0,100	0,100	40-55	0,040-0,050	0,050-0,080	0,080-0,120	0,120
	стали <700 Н/мм ²	30-40	0,040-0,050	0,050-0,080	0,080-0,100	0,100	35-40	0,040-0,050	0,050-0,080	0,080-0,120	0,120
	стали <850 Н/мм ²	25-35	0,040-0,050	0,050-0,080	0,080-0,100	0,100	30-35	0,040-0,050	0,050-0,080	0,080-0,120	0,120
	стали <1000 Н/мм ²	8-12	0,025-0,030	0,030-0,050	0,050-0,070	0,070	10-15	0,020-0,030	0,030-0,050	0,050-0,080	0,080
	стали <1400 Н/мм ²	5-10	0,020	0,020-0,030	0,030-0,040	0,040	8-12	0,020-0,025	0,025-0,030	0,030-0,040	0,040
M	нержавеющие и кислотостойкие стали <700 Н/мм ²	10-15	0,020	0,020-0,030	0,030-0,040	0,040	15-20	0,020-0,025	0,025-0,030	0,030-0,040	0,040
	нержавеющие и кислотостойкие стали >700 Н/мм ²	5-10	0,020	0,020-0,030	0,030-0,040	0,040	10-15	0,020-0,025	0,025-0,030	0,030-0,040	0,040
K	серый чугун <180 HB	-	-	-	-	-	30-35	0,040-0,050	0,050-0,080	0,080-0,120	0,120
N	Al и Al сплавы <6% Si	60-80	0,040-0,050	0,050-0,080	0,080-0,100	0,100	80-90	0,040-0,050	0,050-0,080	0,080-0,120	0,120
	Al и Al сплавы <12% Si	40-50	0,040-0,050	0,050-0,080	0,080-0,100	0,100	50-60	0,040-0,050	0,050-0,080	0,080-0,120	0,120
	Al и Al сплавы >12% Si	-	-	-	-	-	40-50	0,020-0,030	0,030-0,070	0,070-0,080	0,080
	бронза, медь, латунь	70-90	0,040-0,050	0,050-0,080	0,080-0,100	0,100	80-100	0,040-0,050	0,050-0,080	0,080-0,120	0,120
H	закаленные стали 45-55 HRC	-	-	-	-	-	55-60	0,020-0,025	0,025-0,030	0,030-0,040	0,040

Центровочные сверла Zенковки

Центровочные сверла ЧПУ из твердого сплава

Группы обрабатываемых материалов	Vc м/мин	центровочные сверла без покрытия					Vc м/мин	центровочные сверла с покрытием					
		f мм/об.	f мм/об.	f мм/об.	f мм/об.	f мм/об.		f мм/об.	f мм/об.	f мм/об.	f мм/об.		
		d1 - d3	d3 - d5	d5 - d6	d6 - d12	d12 - d20		d1 - d3	d3 - d5	d5 - d6	d6 - d12	d12 - d20	
P	стали <500 Н/мм ²	70-80	0,050-0,060	0,060-0,110	0,110-0,140	0,140-0,160	0,160	80	0,050-0,060	0,060-0,110	0,110-0,140	0,140-0,160	0,160
	стали <700 Н/мм ²	65-75	0,050-0,060	0,060-0,110	0,110-0,140	0,140-0,160	0,160	75	0,050-0,060	0,060-0,110	0,110-0,140	0,140-0,160	0,160
	стали <850 Н/мм ²	55-65	0,050-0,060	0,060-0,110	0,110-0,140	0,140-0,160	0,160	65	0,050-0,060	0,060-0,110	0,110-0,140	0,140-0,160	0,160
	стали <1000 Н/мм ²	40-50	0,040-0,050	0,050-0,090	0,090-0,120	0,120-0,140	0,140	50	0,040-0,050	0,050-0,090	0,090-0,120	0,120-0,140	0,140
	стали <1400 Н/мм ²	25-35	0,030-0,040	0,040-0,090	0,090-0,110	0,110-0,130	0,130	35	0,030-0,040	0,040-0,090	0,090-0,110	0,110-0,130	0,130
	цементируемые стали <1000 Н/мм ²	30-40	0,040-0,050	0,050-0,090	0,090-0,120	0,120-0,140	0,140	40	0,040-0,050	0,050-0,090	0,090-0,120	0,120-0,140	0,140
	азотированные стали <1000 Н/мм ²	30-40	0,040-0,050	0,050-0,090	0,090-0,120	0,120-0,140	0,140	40	0,040-0,050	0,050-0,090	0,090-0,120	0,120-0,140	0,140
	термообрабатываемые стали	40-50	0,040-0,050	0,050-0,090	0,090-0,120	0,120-0,140	0,140	50	0,040-0,050	0,050-0,090	0,090-0,120	0,120-0,140	0,140
M	инструментальные стали	25-35	0,030-0,040	0,040-0,090	0,090-0,110	0,110-0,130	0,130	35	0,030-0,040	0,040-0,090	0,090-0,110	0,110-0,130	0,130
	нержавеющие и кислотостойкие стали <700 Н/мм ²	20-30	0,010	0,010-0,030	0,030-0,070	0,070	0,070	30	0,010	0,010-0,030	0,030-0,070	0,070	0,070
K	нержавеющие и кислотостойкие стали >700 Н/мм ²	20-25	0,010	0,010-0,030	0,030-0,070	0,070	0,070	25	0,010	0,010-0,030	0,030-0,070	0,070	0,070
	серый чугун <180 HB	60-70	0,030-0,040	0,040-0,090	0,090-0,110	0,110-0,130	0,130	70	0,030-0,040	0,040-0,090	0,090-0,110	0,110-0,130	0,130
	ковкий чугун	60-70	0,030-0,040	0,040-0,090	0,090-0,110	0,110-0,130	0,130	70	0,030-0,040	0,040-0,090	0,090-0,110	0,110-0,130	0,130
N	чугун с шаровидным графитом	60-70	0,030-0,040	0,040-0,090	0,090-0,110	0,110-0,130	0,130	70	0,030-0,040	0,040-0,090	0,090-0,110	0,110-0,130	0,130
	Al и Al сплавы <6% Si	180-200	0,020	0,020-0,030	0,030-0,070	0,070	0,070	200	0,020	0,020-0,030	0,030-0,070	0,070	0,070
	Al и Al сплавы <12% Si	160-180	0,020	0,020-0,030	0,030-0,070	0,070	0,070	180	0,020	0,020-0,030	0,030-0,070	0,070	0,070
	Al и Al сплавы >12% Si	140-160	0,020	0,020-0,030	0,030-0,070	0,070	0,070	160	0,020	0,020-0,030	0,030-0,070	0,070	0,070
	бронза, медь, латунь	60-80	0,010	0,010-0,020	0,020-0,060	0,060-0,070	0,070	80	0,010	0,020	0,020-0,060	0,060-0,070	0,070
S	термо и дюропластики	40-50	0,010	0,010-0,020	0,020-0,040	0,040-0,060	0,060	-	-	-	-	-	-
	титан, сплавы титана, никель, никелевые сплавы	25-35	0,010	0,010-0,030	0,030-0,070	0,070	0,070	35	0,010	0,030	0,030-0,070	0,070	0,130
	закаленные стали 45-55 HRC	-	-	-	-	-	-	25	0,040-0,060	0,080	0,080-0,090	0,090-0,120	0,130
H	закаленные стали 55-60 HRC	-	-	-	-	-	-	15	0,040-0,060	0,080	0,080-0,090	0,090-0,120	0,130
	закаленные стали 60-65 HRC	-	-	-	-	-	-	10	0,040-0,060	0,080	0,080-0,090	0,090-0,120	0,130

КОНИЧЕСКИЕ ЗЕНКОВКИ. ЦИЛИНДРИЧЕСКИЙ ХВОСТОВИК. 60°, 75°, 80°, 82°, 120°. DIN334

HSS, VHM

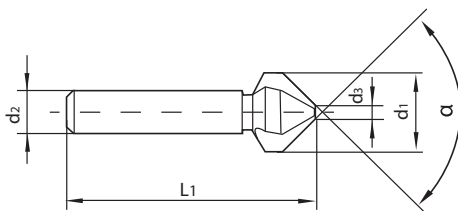

Система обозначений	
D	Диаметр зенковки, мм
L1	Общая длина, мм
d2	Диаметр хвостовика, мм
d3	Диаметр носика, мм
Z	Кол-во зубьев



Материал					HSS	HSS	VHM	HSS	HSS	HSS	HSS	HSS	HSS	
Покрытие					BR	TiN	BR	BR	TiN	BR	BR	BR	TiN	
Угол α°					60°	60°	60°	75°	75°	80°	82°	120°	120°	
Группы обрабатываемых материалов (основное применение)					P	•	•	•	•	•	•	•	•	
					M	○	•	•	○	•	○	○	○	•
					N	•	•	•	•	•	•	•	•	•
					K	•	•	•	•	•	•	•	•	•
					S	○	•	•	○	•	○	○	○	•
D мм	d2 мм	d3 мм	L1	Z	Артикулы									
					STZ13724	STZ13725	STZ43018	STZ13727	STZ13728	STZ13729	STZ13730	STZ13732	STZ13733	
6,3	5	1,7	45	3	•	•								
8	6	2,1	50	3	•	•								
10	6	2,6	53	3	•	•								
12,5	8	3,3	56	3	•	•								
16	10	4,1	63	3	•	•								
20	10	5,1	67	3	•	•								
25,0	10	6,4	71	3	•	•								
31,5	12	10,01	76	3	•	•								
6	5	1,5	45	3						•				
8	6	2	50	3			•			•				
10,0	8	2,5	50	3			•			•				
12,5	8	3,2	56	3			•							
13,4	8	2,9	56	3						•				
16,0	10	4	63	3			•							
16,5	10	3,2	60	3						•				
20	10	5	67	3			•							
20,5	10	3,5	63	3						•				
25,0	10	6,3	71	3			•							
6,3	5	1,6	45	3				•	•					
8,3	6	2,2	50	3				•	•					
10,4	6	2,7	51	3				•	•					
12,4	8	3,2	55	3				•	•					
16,5	10	3,7	61	3				•	•					
20,5	10	4,2	65	3				•	•					
25	10	5,2	69	3				•	•					
31	12	6,2	73	3				•	•					
6,3	5	1,5	45	3							•			
8,3	6	2	50	3							•			
10,4	6	2,5	50	3							•			
12,4	8	2,8	56	3							•			
16,5	10	3,2	60	3							•			
20,5	10	3,5	63	3							•			
25	10	3,8	67	3							•			
6,3	5	1,7	44	3								•	•	
8,3	6	2,2	48,5	3								•	•	
10,4	6	2,7	50	3								•	•	
12,4	8	3,2	53	3								•	•	
16,5	10	3,7	56	3								•	•	
20,5	10	4,2	59	3								•	•	
25	10	5,2	61	3								•	•	
31	12	8,1	68	3								•	•	
40	15	10	74	3								•	•	

Центровые сверла зенковки

HSS, HSSE, HSSE-PM, VHM

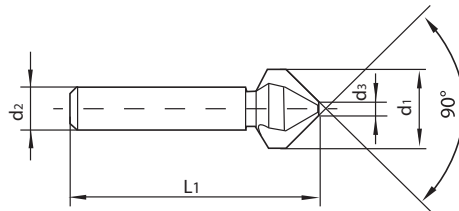

Система обозначений	
D	Диаметр зенковки, мм
L1	Общая длина, мм
d2	Диаметр хвостовика, мм
d3	Диаметр носика, мм
Z	Кол-во зубьев



Центровые сверла зенковки

Материал	HSS	HSS	HSS	HSSE	HSSE	HSSE	HSSE	HSSE-PM	VHM	VHM					
Покрытие	BR	TIN	TiAIN	BR	TIN	TiAIN	BR	BR	BR	STB					
Тип							AZ.	Hardox 400, VA	Hardox 400/500						
Угол α°	90°	90°	90°	90°	90°	90°	90°	90°	90°	90°					
Группы обрабатываемых материалов (основное применение)	P	•	•	•	•	•	•	•	•	•					
	M	○	○	○	•	•	•	•	•	•					
	N	•	•	•	•	•	•	•	•	•					
	K	•	•	•	•	•	•	•	•	•					
	S	○	○	○	•	•	•	•	•	○					
	H									•	•				
D мм	d2 мм	d3 мм	L1	Артикулы											
				STZ13715	STZ13720	STZ13721	STZ23010	STZ23011	STZ23012	STZ33015	STZ33012	STZ43015	STZ43017		
4,3	4	1,3	40	3	•	•		•					•		
4,9					•	•									
5,0		•			•		•	•							
5,3		•			•		•	•						•	
5,7	5	1,5	45	3											
5,8					•	•	•	•	•						
6,0					•	•	•	•	•						
6,3					•	•	•	•	•	•	•	•	•	•	•
7,0					•	•	•	•	•						
7,3					•	•	•	•	•						
7,8	6	1,8	50	3											
8,0					•	•	•	•	•	•	•				
8,3					•	•	•	•	•	•	•	•	•	•	•
9															
9,4		•			•	•	•	•	•	•	•				
9,5															
10,0	10	2,2	50	3	•	•	•	•	•	•					
10,4					•	•	•	•	•	•	•	•	•	•	•
11,4															
11,5		•			•	•	•	•	•	•	•				
12,0		•			•	•	•	•	•	•	•	•	•	•	
12,4		•			•	•	•	•	•	•	•	•	•	•	
13,4	8	2,8	56	3	•	•	•	•	•	•					
15,0					•	•	•	•	•	•	•	•			
15,4															
16,5		•			•	•	•	•	•	•	•	•	•	•	•
18,5		•			•	•	•	•	•	•	•	•	•	•	•
19,0		•			•	•	•	•	•	•	•	•	•	•	•
20,5	10	3,2	60	3											
22,5					•	•	•	•	•	•	•	•	•	•	•
23,0					•	•	•	•	•	•	•	•	•	•	•
25,0		•			•	•	•	•	•	•	•	•	•	•	
26,0		•			•	•	•	•	•	•	•	•	•	•	
28,0		•			•	•	•	•	•	•	•	•	•	•	
30,0	12	4,0	71	3	•	•	•	•	•	•					
31,0					•	•	•	•	•	•	•	•	•	•	•
35					•	•	•	•	•	•	•	•	•	•	•
40	16	5	75	3											
40					•	•	•	•	•	•	•	•	•	•	•
40					•	•	•	•	•	•	•	•	•	•	•
50	16	4,5	103	3											
40					•	•	•	•	•	•	•	•	•	•	•
40	16	5	118	3											
50					•	•	•	•	•	•	•	•	•	•	•

HSS, HSSE

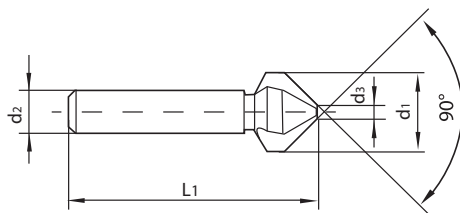

Система обозначений	
D	Диаметр зенковки, мм
L1	Общая длина, мм
d2	Диаметр хвостовика, мм
d3	Диаметр носика, мм
Z	Кол-во зубьев

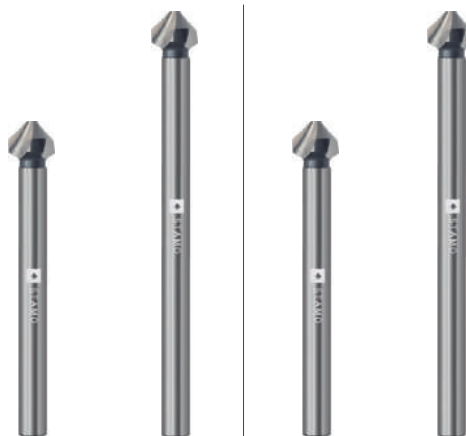

Материал					HSS	HSS	HSSE	HSSE
Покрытие					(BR)	(BR)	(BR)	(BR)
Тип					XL	XXL	XL	XL
Угол α°					90°	90°	90°	90°
Группы обрабатываемых материалов (основное применение)					P	•	•	•
					M	○	○	○
					N	•	•	•
					K	•	•	•
					S	○	○	•
					H			
D мм	d2 мм	d3 мм	L1	Z				
					STZ14715	STZ15715	STZ33014	STZ23013
5,8	5	1,5	104	3	•			
6,3			85		•		•	
8,3	6	2,0	85		•		•	
9,4			106		•			
10,4			85		•		•	
11,5			108		•			
12,4	8	2,8	108		•		•	
15			109		•			
16,5	10	3,2	112		•		•	
20,5			115		•		•	
25,0			118	•		•		
31	12	4,2	120			•		
			140	•				
6,3	5	1,5	154	3		•		•
8,3			155			•		•
10,4	6	2,5	157			•		•
12,4			158			•		•
15	10	3,2	159			•		•
16,5			161			•		•
20,5			164			•		•
25	12	3,8	168			•		•
31			190			•		•

Центровые сверла зенковки

HSS

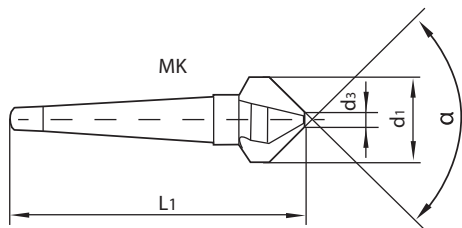

Система обозначений	
D	Диаметр зенковки, мм
L1	Общая длина, мм
KM	Конус Морзе
d3	Диаметр носика, мм
Z	Кол-во зубьев



Материал					HSS	HSS	HSS
Покрытие					(BR)	(BR)	(TiN)
Угол α°					60°	90°	90°
Группы обрабатываемых материалов (основное применение)					P	•	•
					M	○	○
					N	•	•
					K	•	•
					S	○	○
D, мм	KM	d3 мм	L1	Z	Артикулы		
					STZ13734	STZ13716	STZ13717
25	2	6,3	112	3	•		
31,5	2	10	118	3	•		
40	3	12,5	150	3	•		
50	3	16	160	3	•		
63	4	20	190	3	•		
80	4	25	200	3	•		
15,0	1	3,2	85	3		•	
16,5	1	3,2	85	3		•	•
19,0	2	3,5	100	3		•	
20,5	2	3,5	100	3		•	•
23,0	2	3,8	106	3		•	
25,0	2	3,8	106	3		•	•
26,0	2	3,8	106	3		•	
28,0	2	4,0	112	3		•	
30,0	2	4,2	112	3		•	•
31,0	2	4,2	112	3		•	•
34,0	2	4,5	118	3		•	•
37,0	2	4,8	118	3		•	•
40,0	3	10,0	140	3		•	•
45,0	3	12,0	145	3		•	
50,0	3	14,0	150	3		•	•
63,0	4	16,0	180	3		•	•
80	4	22	190	3		•	•
100	4	28	200	3		•	

Центров-
сверла
зенковки

Зенковки из быстрорежущей стали

Группы обрабатываемых материалов	Vс м/мин без покрытия	Vс м/мин с покрытием	Зенковки из HSS, HSSE, HSSE-PM							
			f мм/об.	f мм/об.	f мм/об.	f мм/об.	f мм/об.	f мм/об.	f мм/об.	
			d4,3-5	d6,3-8	d8,3-12,4	d15-d20	d20,5-d35	d37-d60	d63-d100	
P	стали <500 Н/мм ²	20-30	30-40	0,050-0,080	0,080-0,100	0,100-0,130	0,130-0,160	0,160-0,220	0,220-0,350	0,350-0,450
	стали <700 Н/мм ²	20-30	30-40	0,050-0,080	0,080-0,100	0,100-0,130	0,130-0,160	0,160-0,220	0,220-0,350	0,350-0,450
	стали <850 Н/мм ²	15-25	20-30	0,050-0,080	0,080-0,100	0,100-0,130	0,130-0,160	0,160-0,220	0,220-0,350	0,350-0,450
	стали <1000 Н/мм ²	15-25	20-30	0,040-0,060	0,060-0,070	0,070-0,090	0,090-0,120	0,060-0,100	0,160-1,250	0,250-0,300
	стали <1400 Н/мм ²	2-5	3-6	0,020-0,030	0,030-0,040	0,040-0,050	0,090-0,120	0,120-0,160	0,100-0,140	0,140-0,200
	цементируемые стали <1000 Н/мм ²	20-30	20-35	0,040-0,060	0,060-0,070	0,070-0,090	0,090-0,120	0,120-0,160	0,160-0,250	0,250-0,300
	азотированные стали <1000 Н/мм ²	15-25	20-30	0,040-0,060	0,060-0,070	0,070-0,090	0,090-0,120	0,120-0,160	0,160-0,250	0,250-0,300
	термообрабатываемые стали	15-25	20-30	0,040-0,060	0,060-0,070	0,070-0,090	0,090-0,120	0,120-0,160	0,160-0,250	0,250-0,300
	инструментальные стали	10-25	20-30	0,040-0,060	0,060-0,070	0,070-0,090	0,090-0,120	0,120-0,160	0,160-0,250	0,250-0,300
M	нержавеющие и кислотостойкие стали <700 Н/мм ²	5-10	5-15	0,040-0,050	0,050-0,060	0,060-0,070	0,070-0,080	0,080-0,100	0,100-0,140	0,140-0,200
	нержавеющие и кислотостойкие стали >700 Н/мм ²	5-10	5-15	0,040-0,050	0,050-0,060	0,060-0,070	0,070-0,080	0,080-0,100	0,100-0,140	0,140-0,200
K	серый чугун <180 HB	15-25	20-30	0,070-0,080	0,100-0,120	0,120-0,140	0,150-0,200	0,200-0,280	0,280-0,320	0,320-0,400
	ковкий чугун	10-20	10-25	0,060-0,070	0,080-0,090	0,090-0,100	0,120-0,160	0,160-0,250	0,250-0,280	0,280-0,350
N	Al и Al сплавы <6% Si	60-100	65-120	0,050-0,080	0,100-0,120	0,120-0,140	0,150-0,200	0,200-0,280	0,280-0,380	0,380-0,450
	Al и Al сплавы <12% Si	30-50	35-60	0,050-0,080	0,080-0,100	0,100-0,130	0,130-0,160	0,160-0,220	0,220-0,350	0,350-0,450
	Al и Al сплавы >12% Si	15-30	15-40	0,050-0,080	0,080-0,100	0,100-0,130	0,130-0,160	0,160-0,220	0,220-0,350	0,380-0,450
	бронза, медь, латунь	40-70	60-80	0,050-0,080	0,100-0,120	0,120-0,140	0,150-0,200	0,200-0,280	0,280-0,380	0,380-0,450
	термо и дюропластики	20-50	25-60	0,050-0,080	0,100-0,120	0,120-0,140	0,150-0,200	0,200-0,280	0,280-0,380	0,380-0,450
S	титан, сплавы титана	5-10	5-15	0,040-0,050	0,050-0,060	0,060-0,070	0,070-0,080	0,080-0,100	0,100-0,140	0,140-0,200

Центровые сверла зенковки

Зенковки из твердого сплава

Группы обрабатываемых материалов	Vс м/мин без покрытия	Vс м/мин с покрытием	Зенковки из VHM					
			f мм/об.	f мм/об.	f мм/об.	f мм/об.	f мм/об.	
			d4,3-5	d6,3-8	d8,3-12,4	d15-d20	d20,5-d35	
P	стали <500 Н/мм ²	45-55	50-70	0,050-0,080	0,080-0,100	0,100-0,130	0,130-0,160	0,160-0,220
	стали <700 Н/мм ²	45-55	50-70	0,050-0,080	0,080-0,100	0,100-0,130	0,130-0,160	0,160-0,220
	стали <850 Н/мм ²	45-50	50-65	0,050-0,080	0,080-0,100	0,100-0,130	0,090-0,120	0,160-0,220
	стали <1000 Н/мм ²	45-50	50-65	0,040-0,060	0,060-0,070	0,070-0,090	0,050-0,060	0,120-0,160
	стали <1400 Н/мм ²	8-12	10-15	0,020-0,030	0,030-0,040	0,040-0,050	0,090-0,120	0,060-0,100
	цементируемые стали <1000 Н/мм ²	30-50	40-60	0,040-0,060	0,060-0,070	0,070-0,090	0,090-0,120	0,120-0,160
	азотированные стали <1000 Н/мм ²	30-50	40-60	0,040-0,060	0,060-0,070	0,070-0,090	0,090-0,120	0,120-0,160
	термообрабатываемые стали	40-60	50-70	0,040-0,060	0,060-0,070	0,070-0,090	0,090-0,120	0,120-0,160
	инструментальные стали	12-20	15-25	0,040-0,060	0,060-0,070	0,070-0,090	0,090-0,120	0,120-0,160
M	нержавеющие и кислотостойкие стали <700 Н/мм ²	12-20	15-25	0,040-0,050	0,050-0,060	0,060-0,070	0,070-0,080	0,080-0,100
	нержавеющие и кислотостойкие стали >700 Н/мм ²	12-20	15-25	0,040-0,050	0,050-0,060	0,060-0,070	0,070-0,080	0,080-0,100
K	серый чугун <180 HB	30-50	40-60	0,070-0,080	0,100-0,120	0,120-0,140	0,150-0,200	0,200-0,280
	ковкий чугун	20-30	25-40	0,060-0,070	0,080-0,090	0,090-0,100	0,120-0,160	0,160-0,250
N	Al и Al сплавы <6% Si	120-150	140-180	0,050-0,080	0,100-0,120	0,120-0,140	0,150-0,200	0,200-0,280
	Al и Al сплавы <12% Si	60-90	70-100	0,050-0,080	0,080-0,100	0,100-0,130	0,130-0,160	0,160-0,220
	Al и Al сплавы >12% Si	20-40	30-50	0,050-0,080	0,080-0,100	0,100-0,130	0,130-0,160	0,160-0,220
	бронза, медь, латунь	80-140	90-150	0,050-0,080	0,100-0,120	0,120-0,140	0,150-0,200	0,200-0,280
	термо и дюропластики	20-50	30-60	0,050-0,080	0,100-0,120	0,120-0,140	0,150-0,200	0,200-0,280
	графит	25-45	35-55	0,020-0,035	0,250-0,040	0,040-0,055	0,055-0,070	0,070-0,100
S	титан, сплавы титана	10-15	13-20	0,040-0,050	0,050-0,060	0,060-0,070	0,070-0,080	0,080-0,100

СВЕРЛА

ТВЕРДОСПЛАВНЫЕ



твердо-
сплавные
сверла



ТВЕРДОСПЛАВНЫЕ 3xD - 5xD

универсальное применение

Система обозначений	
d1	диаметр режущей части и хвостовика, мм
Лобц	общая длина, мм
l2	длина рабочей части, мм

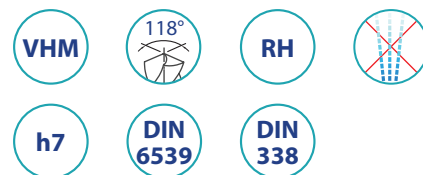
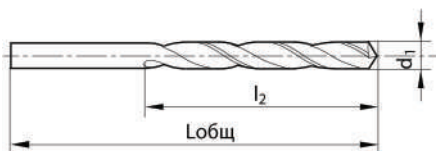

1,4	32	9	•	•	•	•
	40	18				
1,45	32	9	•	•	•	•
	40	18				
1,5	32	9	•	•	•	•
	40	18				
1,55	34	10	•	•	•	•
	43	20				
1,6	34	10	•	•	•	•
	43	20				
1,65	34	10	•	•	•	•
	43	20				
1,7	34	10	•	•	•	•
	43	20				
1,75	36	11	•	•	•	•
	46	22				
1,8	36	11	•	•	•	•
	46	22				
1,85	36	11	•	•	•	•
	46	22				
1,9	36	11	•	•	•	•
	46	22				
1,95	38	12	•	•	•	•
	49	24				
1,98	38	12	•	•	•	•
	49	24				
2	38	12	•	•	•	•
	49	24				
2,05	38	12	•	•	•	•
	49	24				
2,1	38	12	•	•	•	•
	49	24				
2,15	40	13	•	•	•	•
	53	27				
2,2	40	13	•	•	•	•
	53	27				
2,25	40	13	•	•	•	•
	53	27				
2,3	40	13	•	•	•	•
	53	27				
2,35	40	13	•	•	•	•
	53	27				
2,38	43	14	•	•	•	•
	57	30				
2,4	43	14	•	•	•	•
	57	30				
2,45	43	14	•	•	•	•
	57	30				
2,5	43	14	•	•	•	•
	57	30				
2,55	43	14	•	•	•	•
	57	30				
2,6	43	14	•	•	•	•
	57	30				
2,65	43	14	•	•	•	•
	57	30				
2,7	46	16	•	•	•	•
	61	33				
2,75	46	16	•	•	•	•
	61	33				
2,78	46	16	•	•	•	•
	61	33				
2,8	46	16	•	•	•	•
	61	33				

Глубина обработки	3xD	3xD	5xD	5xD		
Материал	VHM	VHM	VHM	VHM		
Покрытие	BR	TiAIN	BR	TiAIN		
Группы обрабатываемых материалов	P	o	o	o		
	M	o	o	o		
	N	•	•	•		
	K	o	o	o		
	S	o	o	o		
Основное применение	H					
d1	Лобц	l2	Артикулы			
			STD4410	STD2410	STD4420	STD2420
0,5	22	4	•	•		
	22	6				
0,55	22	4	•	•		
	24	7				
0,6	22	4	•	•		
	24	7				
0,65	22	5	•	•		
	26	8				
0,7	24	5	•	•		
	28	9				
0,75	24	5	•	•		
	28	9				
0,8	24	5	•	•		
	30	10				
0,85	24	5	•	•		
	30	10				
0,9	26	6	•	•		
	32	11				
0,95	26	6	•	•		
	32	11				
1	26	6	•	•		
	34	12				
1,05	26	6	•	•		
	34	12				
1,1	28	7	•	•		
	36	14				
1,15	28	7	•	•		
	36	14				
1,2	30	8	•	•		
	38	16				
1,25	30	8	•	•		
	38	16				
1,3	30	8	•	•		
	38	16				
1,35	32	9	•	•		
	40	18				

твердо-сплавные сверла



универсальное применение

Система обозначений	
d1	диаметр режущей части и хвостовика, мм
Лобц	общая длина, мм
l2	длина рабочей части, мм

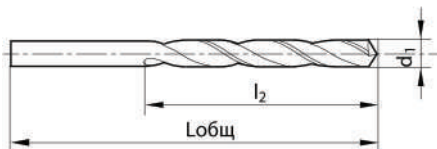

Глубина обработки		3xD	3xD	5xD	5xD	
Материал		VHM	VHM	VHM	VHM	
Покрытие		BR	TiAIN	BR	TiAIN	
Группы обрабатываемых материалов	P	o	o	o	o	
	M	o	o	o	o	
	N	•	•	•	•	
	K	o	o	o	o	
	S	o	o	o	o	
Основное применение		H				
d1	Лобц	l2	Артикулы			
		STD4410 STD2410 STD4420 STD2420				
2,85	46	16	•	•	•	•
	61	33				
2,9	46	16	•	•	•	•
	61	33				
2,95	46	16	•	•	•	•
	61	33				
3	46	16	•	•	•	•
	61	33				
3,05	49	18	•	•	•	•
	65	36				
3,1	49	18	•	•	•	•
	65	36				
3,15	49	18	•	•	•	•
	65	36				
3,17	49	18	•	•	•	•
	65	36				
3,2	49	18	•	•	•	•
	65	36				
3,25	49	18	•	•	•	•
	65	36				
3,3	49	18	•	•	•	•
	65	36				
3,35	52	20	•	•	•	•
	70	39				
3,4	52	20	•	•	•	•
	70	39				
3,45	52	20	•	•	•	•
	70	39				
3,5	52	20	•	•	•	•
	70	39				
3,55	52	20	•	•	•	•
	70	39				
3,57	52	20	•	•	•	•
	70	39				
3,6	52	20	•	•	•	•
	70	39				

3,65	52	20	•	•	•	•
	70	39				
3,7	52	20	•	•	•	•
	70	39				
3,75	52	20	•	•	•	•
	70	39				
3,8	55	22	•	•	•	•
	75	43				
3,85	55	22	•	•	•	•
	75	43				
3,9	55	22	•	•	•	•
	75	43				
3,95	55	22	•	•	•	•
	75	43				
3,97	55	22	•	•	•	•
	75	43				
4	55	22	•	•	•	•
	75	43				
4,05	55	22	•	•	•	•
	75	43				
4,1	55	22	•	•	•	•
	75	43				
4,15	55	22	•	•	•	•
	75	43				
4,2	55	22	•	•	•	•
	75	43				
4,25	55	22	•	•	•	•
	75	43				
4,3	58	24	•	•	•	•
	80	47				
4,35	58	24	•	•	•	•
	80	47				
4,37	58	24	•	•	•	•
	80	47				
4,4	58	24	•	•	•	•
	80	47				
4,45	58	24	•	•	•	•
	80	47				
4,5	58	24	•	•	•	•
	80	47				
4,55	58	24	•	•	•	•
	80	47				
4,6	58	24	•	•	•	•
	80	47				
4,65	58	24	•	•	•	•
	80	47				
4,7	58	24	•	•	•	•
	80	47				
4,75	58	24	•	•	•	•
	80	47				
4,76	62	26	•	•	•	•
	86	52				
4,8	62	26	•	•	•	•
	86	52				
4,85	62	26	•	•	•	•
	86	52				
4,9	62	26	•	•	•	•
	86	52				
4,95	62	26	•	•	•	•
	86	52				
5	62	26	•	•	•	•
	86	52				
5,05	62	26	•	•	•	•
	86	52				

твердо-сплавные сверла



ТВЕРДОСПЛАВНЫЕ 3xD - 5xD

универсальное применение

Система обозначений	
d1	диаметр режущей части и хвостовика, мм
Лобц	общая длина, мм
l2	длина рабочей части, мм

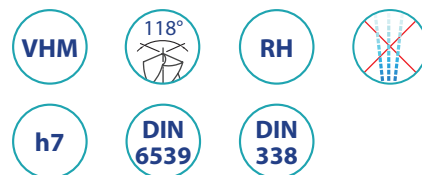
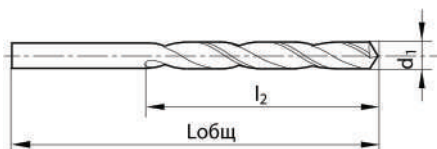

Глубина обработки			3xD	3xD	5xD	5xD
Материал			VHM	VHM	VHM	VHM
Покрытие			BR	TiAIN	BR	TiAIN
Группы обрабатываемых материалов	P	o	o	o	o	
	M	o	o	o	o	
	N	•	•	•	•	
	K	o	o	o	o	
	S	o	o	o	o	
Основное применение			H			
d1	Лобц	l2	Артикулы			
			STD4410	STD2410	STD4420	STD2420
5,1	62	26	•	•		
	86	52			•	•
5,15	62	26	•	•		
	86	52			•	•
5,16	62	26	•	•		
	86	52			•	•
5,2	62	26	•	•		
	86	52			•	•
5,25	62	26	•	•		
	86	52			•	•
5,3	62	26	•	•		
	86	52			•	•
5,35	66	28	•	•		
	93	57			•	•
5,4	66	28	•	•		
	93	57			•	•
5,45	66	28	•	•		
	93	57			•	•
5,5	66	28	•	•		
	93	57			•	•
5,55	66	28	•	•		
	93	57			•	•
5,56	66	28	•	•		
	93	57			•	•
5,6	66	28	•	•		
	93	57			•	•
5,65	66	28	•	•		
	93	57			•	•
5,7	66	28	•	•		
	93	57			•	•
5,75	66	28	•	•		
	93	57			•	•
5,8	66	28	•	•		
	93	57			•	•
5,85	66	28	•	•		
	93	57			•	•

5,9	66	28	•	•		
	93	57			•	•
5,95	66	28	•	•		
	93	57			•	•
6	66	28	•	•		
	93	57			•	•
6,1	70	31	•	•		
	101	63			•	•
6,2	70	31	•	•		
	101	63			•	•
6,3	70	31	•	•		
	101	63			•	•
6,35	70	31	•	•		
	101	63			•	•
6,4	70	31	•	•		
	101	63			•	•
6,5	70	31	•	•		
	101	63			•	•
6,6	70	31	•	•		
	101	63			•	•
6,7	70	31	•	•		
	101	63			•	•
6,8	74	34	•	•		
	109	69			•	•
6,9	74	34	•	•		
	109	69			•	•
7	74	34	•	•		
	109	69			•	•
7,1	74	34	•	•		
	109	69			•	•
7,14	74	34	•	•		
	109	69			•	•
7,2	74	34	•	•		
	109	69			•	•
7,3	74	34	•	•		
	109	69			•	•
7,4	74	34	•	•		
	109	69			•	•
7,5	74	34	•	•		
	109	69			•	•
7,6	79	37	•	•		
	117	75			•	•
7,7	79	37	•	•		
	117	75			•	•
7,8	79	37	•	•		
	117	75			•	•
7,9	79	37	•	•		
	117	75			•	•
7,94	79	37	•	•		
	117	75			•	•
8	79	37	•	•		
	117	75			•	•
8,1	79	37	•	•		
	117	75			•	•
8,2	79	37	•	•		
	117	75			•	•
8,3	79	37	•	•		
	117	75			•	•
8,4	79	37	•	•		
	117	75			•	•
8,5	79	37	•	•		
	117	75			•	•
8,6	84	40	•	•		
	125	81			•	•

универсальное применение

Система обозначений	
d1	диаметр режущей части и хвостовика, мм
Лобц	общая длина, мм
l2	длина рабочей части, мм

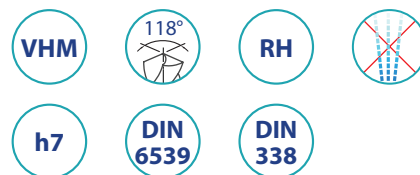
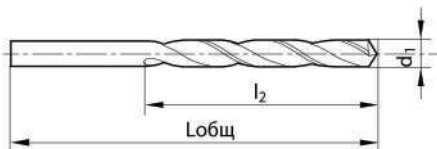

Глубина обработки			3xD	3xD	5xD	5xD
Материал			VHM	VHM	VHM	VHM
Покрытие			BR	TiAIN	BR	TiAIN
Группы обрабатываемых материалов Основное применение	P		o	o	o	o
	M		o	o	o	o
	N		•	•	•	•
	K		o	o	o	o
	S		o	o	o	o
H						
d1	Лобц	l2	Артикулы			
			STD4410	STD2410	STD4420	STD2420
8,7	84	40	•	•		
	125	81			•	•
8,73	84	40	•	•		
	125	81			•	•
8,8	84	40	•	•		
	125	81			•	•
8,9	84	40	•	•		
	125	81			•	•
9	84	40	•	•		
	125	81			•	•
9,1	84	40	•	•		
	125	81			•	•
9,2	84	40	•	•		
	125	81			•	•
9,3	84	40	•	•		
	125	81			•	•
9,4	84	40	•	•		
	125	81			•	•
9,5	84	40	•	•		
	125	81			•	•
9,6	89	43	•	•		
	133	87			•	•
9,7	89	43	•	•		
	133	87			•	•
9,8	89	43	•	•		
	133	87			•	•
9,9	89	43	•	•		
	133	87			•	•
10	89	43	•	•		
	133	87			•	•
10,1	89	43	•	•		
	133	87			•	•
10,2	89	43	•	•		
	133	87			•	•
10,3	89	43	•	•		
	133	87			•	•

10,4	89	43	•	•		
	133	87			•	•
10,5	89	43	•	•		
	133	87			•	•
10,6	95	47	•	•		
	142	94			•	•
10,7	95	47	•	•		
	142	94			•	•
10,72	95	47	•	•		
	142	94			•	•
10,8	95	47	•	•		
	142	94			•	•
10,9	95	47	•	•		
	142	94			•	•
11	95	47	•	•		
	142	94			•	•
11,1	95	47	•	•		
	142	94			•	•
11,11	95	47	•	•		
	142	94			•	•
11,2	95	47	•	•		
	142	94			•	•
11,3	95	47	•	•		
	142	94			•	•
11,4	95	47	•	•		
	142	94			•	•
11,5	95	47	•	•		
	142	94			•	•
11,6	95	47	•	•		
	142	94			•	•
11,7	95	47	•	•		
	142	94			•	•
11,8	95	47	•	•		
	142	94			•	•
11,9	95	47	•	•		
	142	94			•	•
11,91	95	47	•	•		
	151	101			•	•
12	102	51	•	•		
	151	101			•	•
12,3	102	51	•	•		
13	102	51	•	•		
14	107	54	•	•		
15	111	56	•	•		
16	115	58	•	•		

универсальное применение

Система обозначений	
d1	диаметр режущей части, мм
Лобц	общая длина, мм
l2	длина рабочей части, мм
dxв	Диаметр хвостовика, мм
lхв	длина хвостовика, мм
tmax	максимальная глубина резания, мм

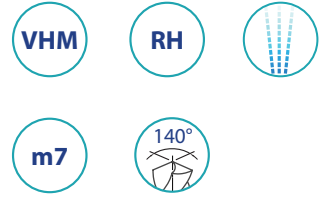
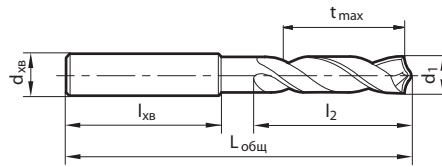

Глубина обработки	3xD					5xD					7xD							
	3xD	3xD	5xD	5xD	7xD	3xD	3xD	5xD	5xD	7xD	3xD	3xD	5xD	5xD	7xD			
Материал	VHM					VHM					VHM							
Покрытие	TiAlN					TiAlN					TiAlN							
Группы обрабатываемых материалов Основное применение	P	•	•	•	•	•	•	•	•	•	•	•	•	•	•			
	M	○	○	○	○	○	○	○	○	○	○	○	○	○	○			
	N	○	○	○	○	○	○	○	○	○	○	○	○	○	○			
	K	•	•	•	•	•	•	•	•	•	•	•	•	•	•			
	S	○	○	○	○	○	○	○	○	○	○	○	○	○	○			
	H	○	○	○	○	○	○	○	○	○	○	○	○	○	○			
d1	Лобц	l2	dxв	lхв	tmax	Артикулы												
STD3410 STD3412 STD3420 STD3422 STD3432																		
0,5	50	10	3	30														
0,6																		
0,7																		
0,8																		
0,9																		
1																		
1,1																		
1,2																		
1,3																		
1,4																		
1,5																		
1,6																		
1,7																		
1,8																		
1,9																		
2																		
2,1																		
2,2																		
2,3																		
2,4																		
2,5																		
2,6																		
2,7																		
2,8																		
2,9																		
3																		
3,1																		
3,17																		
3,2																		
3,25																		
3,3																		
3,4																		
3,5																		
3,57																		
3,6																		
3,7																		
3,8																		

твердо-сплавные сверла



универсальное применение

Система обозначений	
d1	диаметр режущей части, мм
Лобщ	общая длина, мм
l2	длина рабочей части, мм
dxв	Диаметр хвостовика, мм
lхв	длина хвостовика, мм
tmax	максимальная глубина резания, мм

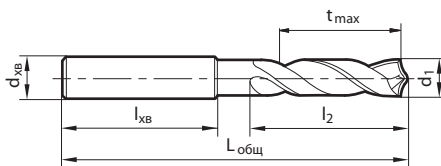

Глубина обработки	3xD	3xD	5xD	5xD	7xD						
Материал	VHM	VHM	VHM	VHM	VHM						
Покрытие	TiAIN	TiAIN	TiAIN	TiAIN	TiAIN						
Группы обрабатываемых материалов Основное применение	P	•	•	•	•						
	M	○	○	○	○						
	N	○	○	○	○						
	K	•	•	•	•						
	S	○	○	○	○						
H	○	○	○	○	○						
d1	Лобщ	l2	dxв	lхв	tmax	Артикулы					
STD3410 STD3412 STD3420 STD3422 STD3432											
3,9	66	24	6	36	18,2	•	•				
	74	36			30,2		•				
	75	37,5			31,7			•			•
3,97	66	24			18	•	•				
	74	36			30			•			•
	75	37,5			31,5						•
4	66	24			18	•	•				
	74	36			30			•	•		
	75	37,5			31,5						•
4,1	66	24			17,9	•	•				
	74	36			29,9			•	•		
	75	37,5			31,4						•
4,2	66	24			17,7	•	•				
	74	36			29,7			•	•		
	75	37,5			31,2						•
4,3	66	24	17,6	•	•						
	74	36	29,6			•	•				
	85	45	38,6						•		
4,37	66	24	17,4	•	•						
	74	36	29,4			•	•				
	85	45	38,4						•		
4,4	66	24	17,4	•	•						
	74	36	29,4			•	•				
	85	45	38,4						•		
4,5	66	24	17,3	•	•						
	74	36	29,3			•	•				
	85	45	38,3						•		
4,6	66	24	17,1	•	•						
	74	36	29,1			•	•				
	85	45	38,1						•		
4,65	66	24	17	•	•						
	74	36	29			•	•				
	85	45	38						•		

4,7	66	24	6	36	17	•	•			
	74	36			29		•	•		
	85	45			38					•
4,76	66	28			20,9	•	•			
	82	44			36,9			•	•	
	90	50			42,9					•
4,8	66	28			20,8	•	•			
	82	44			36,8			•	•	
	90	50			42,8					•
4,9	66	28			20,7	•	•			
	82	44			36,7			•	•	
	90	50			42,7					•
5	66	28			20,5	•	•			
	82	44			36,5			•	•	
	90	50			42,5					•
5,1	66	28	20,4	•	•					
	82	44	36,4			•	•			
	90	50	42,4					•		
5,16	66	28	20,3	•	•					
	82	44	36,3			•	•			
	90	50	42,3					•		
5,2	66	28	20,2	•	•					
	82	44	36,2			•	•			
	90	50	42,2					•		
5,3	66	28	20,1	•	•					
	82	44	36,1			•	•			
	90	50	42,1					•		
5,4	66	28	19,9	•	•					
	82	44	35,9			•	•			
	97	57	48,9					•		
5,5	66	28	19,8	•	•					
	82	44	35,8			•	•			
	97	57	48,8					•		
5,55	66	28	19,7	•	•					
	82	44	35,7			•	•			
	90	50	42,7					•		
5,56	66	28	19,7	•	•					
	82	44	35,7			•	•			
	90	50	42,7					•		
5,6	66	28	19,6	•	•					
	82	44	35,6			•	•			
	90	50	42,6					•		
5,7	66	28	19,5	•	•					
	82	44	35,5			•	•			
	97	57	48,5					•		
5,8	66	28	19,3	•	•					
	82	44	35,3			•	•			
	97	57	48,3					•		
5,9	66	28	19,2	•	•					
	82	44	35,2			•	•			
	97	57	48,2					•		
5,95	66	28	19,1	•	•					
	82	44	35,1			•	•			
	97	57	48,1					•		
6	66	28	19	•	•					
	82	44	35			•	•			
	97	57	48			•	•			
6,1	91	53	43,9			•	•			
	79	34	24,7	•	•					
	91	53	43,7			•	•			
6,2	106	66	56,7					•		
	79	34	24,6	•	•					
	91	53	43,6			•	•			
6,3	106	66	56,6					•		
	79	34	24,5	•	•					
	91	53	43,5			•	•			
6,35	106	66	56,5					•		
	79	34	24,4	•	•					
	91	53	43,4			•	•			

твердо-сплавные сверла

универсальное применение

Система обозначений	
d1	диаметр режущей части, мм
Лобщ	общая длина, мм
l2	длина рабочей части, мм
dxв	Диаметр хвостовика, мм
lxв	длина хвостовика, мм
tmax	максимальная глубина резания, мм

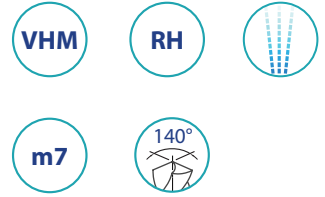
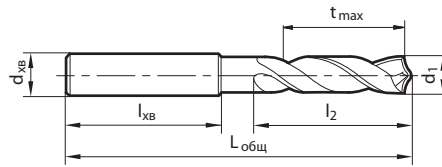

Диаметр (мм)	Лобщ (мм)	l2 (мм)	dxв (мм)	lxв (мм)	tmax (мм)	Стандарты	Группы материалов	Основные применения	
7,54	79	41	8	36	29,7	36	•	•	
	91	53			41,7		•	•	
	79	41			29,6		•	•	
7,6	91	53	8	36	41,6	36	•	•	
	116	76			64,6			•	
7,7	79	41	8	36	29,5	36	•	•	
	91	53			41,5			•	•
	116	76			64,5			•	
7,8	79	41	8	36	29,3	36	•	•	
	91	53			41,3			•	•
	116	76			64,3			•	
7,9	91	53	8	36	29,2	36			
	116	76			41,2				
7,94	79	41	8	36	29,1	36	•	•	
	91	53			41,1			•	•
8	79	41	8	36	29	36	•	•	
	91	53			41			•	•
	116	76			64			•	
8,1	89	47	8	36	34,9	36	•	•	
	103	61			48,9			•	•
	131	87			74,9			•	
8,2	89	47	8	36	34,7	36	•	•	
	103	61			48,7			•	•
8,3	131	87	8	36	74,7	36		•	
	89	47			34,6		•	•	
8,33	103	61	8	36	48,6	36		•	
	89	47			34,5			•	•
8,4	103	61	8	36	48,5	36		•	
	131	87			74,4			•	•
	89	47			34,3		•	•	
8,5	103	61	8	36	48,3	36		•	
	131	87			74,3			•	
8,6	89	47	8	36	34,1	36	•	•	
	103	61			48,1			•	•
8,7	131	87	8	36	74,1	36		•	
	89	47			34		•	•	
8,73	103	61	8	36	48	36		•	
	131	87			74			•	•
	89	47			33,9		•	•	
8,8	103	61	8	36	47,9	36		•	
	89	47			33,8		•	•	
8,9	103	61	8	36	47,8	36		•	
	131	87			73,8			•	•
	89	47			33,7		•	•	
9	103	61	8	36	47,7	36		•	
	89	47			33,5		•	•	
	103	61			47,5			•	•
9,1	131	87	8	36	73,5	36		•	
	89	47			33,4		•	•	
	103	61			47,4			•	•
9,13	139	95	8	36	81,4	36		•	
	89	47			33,3			•	•
9,2	103	61	8	36	47,3	36		•	
	89	47			33,2		•	•	
9,25	103	61	8	36	47,2	36		•	
	139	95			81,2			•	•
	89	47			33,1		•	•	
9,3	103	61	8	36	47,1	36		•	
	139	95			81,1			•	•
	89	47			32,9		•	•	
9,4	103	61	8	36	46,9	36		•	
	139	95			80,9			•	•

твердо-сплавные сверла

универсальное применение

Система обозначений	
d1	диаметр режущей части, мм
Лобщ	общая длина, мм
l2	длина рабочей части, мм
dxв	Диаметр хвостовика, мм
lхв	длина хвостовика, мм
tmax	максимальная глубина резания, мм

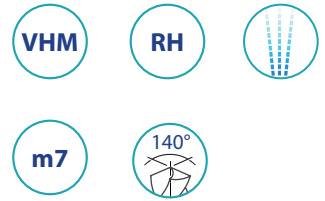
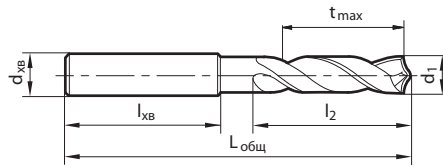

Глубина обработки	3xD	3xD	5xD	5xD	7xD					
Материал	VHM	VHM	VHM	VHM	VHM					
Покрытие	TiAIN	TiAIN	TiAIN	TiAIN	TiAIN					
Группы обрабатываемых материалов Основное применение	P	•	•	•	•					
	M	○	○	○	○					
	N	○	○	○	○					
	K	•	•	•	•					
	S	○	○	○	○					
	H	○	○	○	○					
d1	Лобщ	l2	dxв	lхв	tmax	Артикулы				
STD3410 STD3412 STD3420 STD3422 STD3432										
9,5	89	47	10	40	32,8	•	•			
	103	61			46,8		•			
	139	95			80,8				•	
9,52	89	47			32,7	•	•			
	103	61			46,7			•		
	139	95			80,7				•	
9,6	89	47			32,6	•	•			
	103	61			46,6			•		
	139	95			80,5					•
9,7	89	47			32,3	•	•			
	103	61	46,5			•				
	139	95	80,5					•		
9,8	89	47	32,3	•	•					
	103	61	46,3			•				
	139	95	80,3					•		
9,9	89	47	32,2	•	•					
	103	61	46,2			•				
	139	95	80,2					•		
9,92	89	47	32,1	•	•					
	103	61	46,1			•				
	139	95	80,1					•		
10	89	47	32	•	•					
	103	61	46			•				
	139	95	80					•		
10,1	102	55	39,9	•	•					
	118	71	55,9			•				
	155	106	90,7					•		
10,2	102	55	39,7	•	•					
	118	71	55,7			•				
	155	106	90,7					•		
10,3	102	55	39,6	•	•					
	118	71	55,6			•				
	155	106	90,6					•		
10,32	118	71	55,5							
	102	55	39,4	•	•					
	118	71	55,4			•				
10,4	102	55	39,3	•	•					
	118	71	55,3			•				
	155	106	90,3					•		

10,6	102	55	12	45	39,1					
	118	71			55,1					
10,7	102	55			39	•	•			
	118	71			55			•	•	
10,8	102	55			38,8	•	•			
	118	71			54,8			•	•	
	155	106			89,8					•
10,9	102	55			38,7	•	•			
	118	71			54,7			•	•	
11	102	55			38,5	•	•			
	118	71			54,5			•	•	
	155	106			89,5					•
11,1	102	55			38,4	•	•			
	118	71			54,4			•	•	
11,11	102	55			38,3	•	•			
	118	71			54,3			•	•	
11,2	102	55			38,2	•	•			
	118	71			54,2			•	•	
11,3	102	55			38,1	•	•			
	118	71			54,1			•	•	
	163	114	97,2					•		
11,4	102	55	37,9	•	•					
	118	71	53,9			•	•			
11,5	102	55	37,8	•	•					
	118	71	53,8			•	•			
	163	114	96,8					•		
11,6	102	55	37,6							
	118	71	53,6							
11,7	102	55	37,5	•	•					
	118	71	53,5			•	•			
11,8	102	55	37,3	•	•					
	118	71	53,3			•	•			
	163	114	96,3					•		
11,9	102	55	37,2	•	•					
	118	71	53,2			•	•			
11,91	102	55	37,1							
	118	71	53,1							
12	102	55	37	•	•					
	118	71	53			•	•			
	163	114	96					•		
12,1	107	60	41,9	•	•					
	124	77	58,9			•	•			
	182	133	114,9					•		
12,2	107	60	41,7	•	•					
	124	77	58,7			•	•			
	182	133	114,7					•		
12,3	107	60	41,6	•	•					
	124	77	58,6			•	•			
12,4	107	60	41,4	•	•					
	124	77	58,4			•	•			
12,5	107	60	41,3	•	•					
	124	77	58,3			•	•			
	182	133	114,3					•		
12,6	107	60	41,1							
	124	77	58,1							
	107	60	41	•	•					
12,7	124	77	58			•	•			
	182	133	114					•		
	107	60	40,8	•	•					
12,8	124	77	57,8			•	•			
	107	60	40,5	•	•					
	182	133	113,5					•		
13,1	124	77	57,4			•	•			
	182	133	113,4					•		
	107	60	40,2							

твердо-сплавные сверла

универсальное применение

Система обозначений	
d1	диаметр режущей части, мм
Лобщ	общая длина, мм
l2	длина рабочей части, мм
dxв	Диаметр хвостовика, мм
lхв	длина хвостовика, мм
tmax	максимальная глубина резания, мм

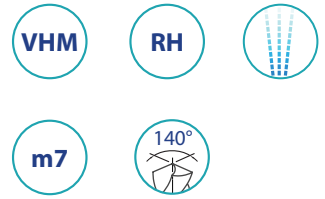
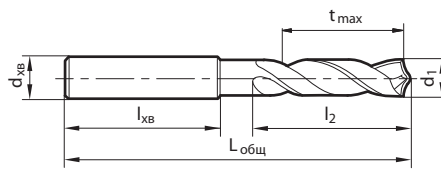

твердо-сплавные сверла

Глубина обработки	3xD	3xD	5xD	5xD	7xD					
Материал	VHM	VHM	VHM	VHM	VHM					
Покрывтие	TiAIN	TiAIN	TiAIN	TiAIN	TiAIN					
Группы обрабатываемых материалов Основное применение	P	•	•	•	•					
	M	○	○	○	○					
	N	○	○	○	○					
	K	•	•	•	•					
	S	○	○	○	○					
	H	○	○	○	○					
d1	Лобщ	l2	dxв	lхв	tmax	Артикулы				
						STD3410	STD3412	STD3420	STD3422	STD3432
13,3	107	60	14	45	40,1	•	•			
	124	77			57,1		•			
107	60	39,8			•	•				
124	77	56,8				•				
182	133	112,8							•	
107	60	39,5			•	•				
124	77	56,5				•				
107	60	39,3								
124	77	56,3								
107	60	39			•	•				
124	77	56				•				
182	133	112								•
115	65	43,9			•	•				
133	83	61,9							•	
204	152	130,9						•		
115	65	43,7	•	•						
133	83	61,7					•			
204	152	130,7						•		
115	65	43,6	•	•						
133	83	61,6					•			
204	152	130,3						•		
115	65	43,4								
115	65	43,3	•	•						
133	83	61,3					•			
204	152	130,3						•		
115	65	43,1	•	•						
115	65	43								
133	83	61								
133	83	60,8	•	•						
115	65	42,5	•	•						
133	83	60,5					•			
204	152	129,5						•		

15,1	115	65	16	48	42,4	•	•			
	133	83			60,4		•	•		
	204	152			129,4					•
15,2	115	65			42,2	•	•			
	133	83			60,2		•	•		
15,3	133	83			60,1					
	115	65			41,8	•	•			
15,5	133	83			59,8		•	•		
	204	152			128,8					•
	115	65			41,5	•	•			
15,7	133	83			59,5					•
	115	65			41,3	•	•			
15,8	133	83			59,3		•	•		
	115	65			41	•	•			
16	133	83			59		•	•		
	204	152			128					•
	123	73			48,9					
16,1	123	73			48,7					
	123	73			48,3	•	•			
16,5	143	93			68,3		•	•		
	223	171			146,3					•
	143	93			67,7		•	•		
16,9	223	171			145,7					•
	123	73			47,5	•	•			
17	143	93	67,5		•	•				
	223	171	145,5					•		
	123	73	47,1							
17,3	123	73	46,8	•	•					
	143	93	66,8		•	•				
	223	171	144,8					•		
17,5	123	73	46	•	•					
	143	93	66,8		•	•				
	223	171	144,8					•		
18	123	73	46	•	•					
	143	93	66,8		•	•				
	223	171	144,8					•		
18,5	131	79	51,3	•	•					
	153	101	101		•	•				
	244	190	190					•		
18,9	153	101	72,7		•					
	131	79	79					•		
	244	190	190					•		
19	131	79	50,5	•	•					
	153	101	101		•	•				
	244	190	190					•		
19,05	153	101	72,4					•		
	244	190	190					•		
19,5	131	79	49,8	•	•					
	153	101	101		•	•				
	244	190	190					•		
20	131	79	49	•	•					
	153	101	101		•	•				
	244	190	190					•		

VA

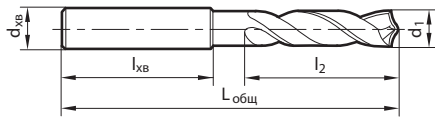

Система обозначений	
d1	диаметр режущей части, мм
d2,h6	диаметр хвостовика, мм
Lобщ	общая длина, мм
L2	длина рабочей части
dхв,h6	диаметр хвостовика, мм



Глубина	3xD	5xD	8xD				
Тип	VA	VA	VA				
Внутренний подвод СОЖ	IKZ	IKZ	IKZ				
Хвостовик	HA	HA	HA				
Угол при вершине	135°	135°	135°				
Покрытие	TiAlN	TiAlN	TiAlN				
Группы обрабатываемых материалов. Основное применение	P	o	o				
	M	•	•				
	N	•	•				
	K	•	•				
	S	•	•				
H							
d1	d2,h6	Lобщ	L2	tmax	Артикулы		
					STD7412	STD7422	STD7432
3	6	62	20	14	•		
		66	28	23		•	
		72	34	27			•
3,1		62	20	14	•		
		66	28	23		•	
		72	34	27			•
3,2	62	20	14	•			
	66	28	23		•		
	72	34	27			•	
3,3	62	20	14	•			
	66	28	23		•		
	72	34	27			•	
3,4	62	20	14	•			
	66	28	23		•		
	72	34	27			•	
3,5	62	20	14	•			
	66	28	23		•		
	72	34	27			•	
3,6	62	20	14	•			
	66	28	23		•		
	72	34	27			•	
3,7	62	20	14	•			
	66	28	23		•		
	86	43	35			•	
3,8	66	24	17	•			
	74	36	29		•		
	86	43	35			•	
3,9	66	24	17	•			
	74	36	29		•		
	86	43	35			•	

4	6	66	24	17	•		
		74	36	29		•	
		86	43	35			•
4,1		66	24	17	•		
		74	36	29		•	
		86	43	35			•
4,2	66	24	17	•			
	74	36	29		•		
	86	43	35			•	
4,3	66	24	17	•			
	74	36	29		•		
	86	43	35			•	
4,4	66	24	17	•			
	74	36	29		•		
	86	43	35			•	
4,5	66	24	17	•			
	74	36	29		•		
	86	43	35			•	
4,6	66	24	17	•			
	74	36	29		•		
	86	43	35			•	
4,65	74	36	29	•	•		
	66	24	17	•			
	74	36	29	•			
4,7	66	24	17	•			
	74	36	29		•		
	95	57	35			•	
4,8	66	28	20	•			
	82	44	35		•		
	95	57	45			•	
4,9	66	28	20	•			
	82	44	35		•		
	95	57	45			•	
5	66	28	20	•			
	82	44	35		•		
	95	57	45			•	
5,1	66	28	20	•			
	82	44	35		•		
	95	57	45			•	
5,2	66	28	20	•			
	82	44	35		•		
	95	57	45			•	
5,3	66	28	20	•			
	82	44	35		•		
	95	57	45			•	
5,4	66	28	20	•			
	82	44	35		•		
	95	57	45			•	
5,5	66	28	20	•			
	82	44	35		•		
	95	57	45			•	
5,6	66	28	20	•			
	82	44	35		•		
	95	57	45			•	
5,7	66	28	20	•			
	82	44	35		•		
	95	57	45			•	
5,8	66	28	20	•			
	82	44	35		•		
	95	57	45			•	
5,9	66	28	20	•			
	82	44	35		•		
	95	57	45			•	
6	66	28	20	•			
	82	44	35		•		
	95	57	45			•	

твердо-сплавные сверла



ТВЕРДОСПЛАВНЫЕ ВЫСОКОПРОИЗВОДИТЕЛЬНЫЕ НРС ДЛЯ НЕРЖАВЕЮЩИХ СТАЛЕЙ

VA

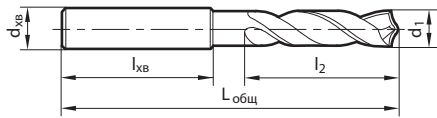

Система обозначений	
d1	диаметр режущей части, мм
d2,h6	диаметр хвостовика, мм
Лобщ	общая длина, мм
L2	длина рабочей части
dхв,h6	диаметр хвостовика, мм



7,1	8	79	41	29	•		
		91	53	43		•	
		114	76	60			•
7,2	8	79	41	29	•		
		91	53	43		•	
		114	76	60			•
7,3	8	79	41	29			•
		91	53	43		•	
		114	76	60			•
7,4	8	79	41	29	•		
		91	53	43		•	
		114	76	60			•
7,5	8	79	41	29			•
		91	53	43		•	
		114	76	60			•
7,6	8	79	41	29	•		
		91	53	43		•	
		114	76	60			•
7,7	8	79	41	29			•
		91	53	43		•	
		114	76	60			•
7,8	8	79	41	29	•		
		91	53	43		•	
		114	76	60			•
7,9	8	79	41	29			•
		91	53	43		•	
		114	76	60			•
8	8	79	41	29	•		
		91	53	43		•	
		114	76	60			•
8,1	10	89	47	35		•	
		103	61	49			•
		142	95	68			•
8,2	10	89	47	35	•		
		103	61	49		•	
		142	95	68			•
8,3	10	89	47	35			•
		103	61	49		•	
		142	95	68			•
8,4	10	89	47	35	•		
		103	61	49		•	
		142	95	68			•
8,5	10	89	47	35			•
		103	61	49		•	
		142	95	68			•
8,6	10	89	47	35	•		
		103	61	49		•	
		142	95	68			•
8,7	10	89	47	35			•
		103	61	49		•	
		142	95	68			•
8,8	10	89	47	35	•		
		103	61	49		•	
		142	95	68			•
8,9	10	89	47	35			•
		103	61	49		•	
		142	95	68			•

Глубина	3xD	5xD	8xD			
Тип	VA	VA	VA			
Внутренний подвод СОЖ	IKZ	IKZ	IKZ			
Хвостовик	HA	HA	HA			
Угол при вершине	135°	135°	135°			
Покрытие	TiAIN	TiAIN	TiAIN			
Группы обрабатываемых материалов. Основное применение	P	o	o	o		
	M	•	•	•		
	N	•	•	•		
	K	•	•	•		
	S	•	•	•		
H						
d1	d2,h6	Лобщ	L2	tmax	Артикулы	
					STD7412	STD7422 STD7432
6,1	8	79	34	24	•	
		91	53	43		•
		114	76	52		
6,2	8	79	34	24	•	
		91	53	43		•
		114	76	52		
6,3	8	79	34	24	•	
		91	53	43		•
		114	76	52		
6,4	8	79	34	24	•	
		91	53	43		•
		114	76	52		
6,5	8	79	34	24	•	
		91	53	43		•
		114	76	52		
6,6	8	79	34	24	•	
		91	53	43		•
		114	76	52		
6,7	8	79	34	24	•	
		91	53	43		•
		114	76	52		
6,8	8	79	34	24	•	
		91	53	43		•
		114	76	52		
6,9	8	79	34	24	•	
		91	53	43		•
		114	76	52		
7	8	79	34	24	•	
		91	53	43		•
		114	76	60		

Твердосплавные сверла

VA

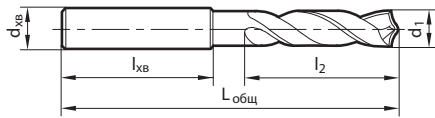

Система обозначений	
d1	диаметр режущей части, мм
d2,h6	диаметр хвостовика, мм
Lобщ	общая длина, мм
L2	длина рабочей части
dхв,h6	диаметр хвостовика, мм



Глубина	3xD	5xD	8xD			
Тип	VA	VA	VA			
Внутренний подвод СОЖ	IKZ	IKZ	IKZ			
Хвостовик	HA	HA	HA			
Угол при вершине	135°	135°	135°			
Покровие						
Группы обрабатываемых материалов. Основное применение	P					
	M					
	N					
	K					
	S					
H						
d1	d2,h6	Lобщ	L2	tmax	Артикулы	
					STD7412	STD7422 STD7432
9	10	89	47	35		
		103	61	49		
		142	95	68		
9,1	10	89	47	35		
		103	61	49		
		142	95	76		
9,2	10	89	47	35		
		103	61	49		
		142	95	76		
9,3	10	89	47	35		
		103	61	49		
		142	95	76		
9,4	10	89	47	35		
		103	61	49		
		142	95	76		
9,5	10	89	47	35		
		103	61	49		
		142	95	76		
9,6	10	89	47	35		
		103	61	49		
		142	95	76		
9,7	10	89	47	35		
		103	61	49		
		142	95	76		
9,8	10	89	47	35		
		103	61	49		
		142	95	76		
9,9	10	89	47	35		
		103	61	49		
		142	95	76		
10	10	89	47	35		

10	12	103	61	49		
		142	95	76		
		102	55	40		
10,1	12	118	71	56		
		162	114	90		
		102	55	40		
10,2	12	118	71	56		
		162	114	90		
		102	55	40		
10,3	12	118	71	56		
		162	114	90		
		102	55	40		
10,4	12	118	71	56		
		162	114	90		
		102	55	35		
10,5	12	118	71	56		
		162	114	90		
		102	55	40		
10,6	12	118	71	56		
		162	114	90		
		102	55	40		
10,7	12	118	71	56		
		162	114	90		
		102	55	35		
10,8	12	118	71	56		
		162	114	90		
		102	55	40		
10,9	12	118	71	56		
		162	114	90		
		102	55	40		
11	12	118	71	56		
		162	114	90		
		102	55	40		
11,1	12	118	71	56		
		162	114	90		
		102	55	40		
11,2	12	118	71	56		
		162	114	90		
		102	55	40		
11,3	12	118	71	56		
		162	114	90		
		102	55	40		
11,4	12	118	71	56		
		162	114	90		
		102	55	40		
11,5	12	118	71	56		
		162	114	90		
		102	55	40		
11,6	12	118	71	56		
		162	114	90		
		102	55	40		
11,7	12	118	71	56		
		162	114	90		
		102	55	40		
11,8	12	118	71	56		
		162	114	90		
		102	55	40		
11,9	12	118	71	56		
		162	114	90		
		102	55	40		
12	12	118	71	56		
		162	114	90		
		102	55	40		

твердо-сплавные сверла



ТВЕРДОСПЛАВНЫЕ ВЫСОКОПРОИЗВОДИТЕЛЬНЫЕ НРС ДЛЯ НЕРЖАВЕЮЩИХ СТАЛЕЙ

VA

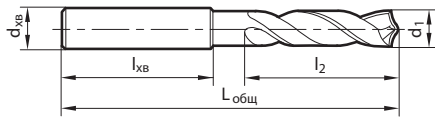

Система обозначений	
d1	диаметр режущей части, мм
d2,h6	диаметр хвостовика, мм
Лобщ	общая длина, мм
L2	длина рабочей части
dxв,h6	диаметр хвостовика, мм



Глубина	3xD	5xD	8xD				
Тип	VA	VA	VA				
Внутренний подвод СОЖ	IKZ	IKZ	IKZ				
Хвостовик	HA	HA	HA				
Угол при вершине	135°	135°	135°				
Покрытие							
Группы обрабатываемых материалов. Основное применение	P	o	o	o			
	M	•	•	•			
	N						
	K						
	S	•	•	•			
H							
d1	d2,h6	Лобщ	L2	tmax	Артикулы		
					STD7412	STD7422 STD7432	
12,2	14	124	77	60		•	
12,3		107	60	43	•		
		124	77	60		•	
12,5		107	60	43	•		
		124	77	60		•	
12,8		178	133	62			•
		107	60	43	•		
		124	77	60		•	
13		178	133	62			•
		107	60	43	•		
		124	77	60		•	
13,3		107	60	45	•		
		107	60	43	•		
		124	77	60		•	
13,5	178	133	62			•	
	107	60	45				
	107	60	43	•			
13,7	124	77	60		•		
	178	133	62			•	
	107	60	43	•			
13,8	124	77	60		•		
	178	133	62			•	
	107	60	43	•			
14	124	77	60		•		
	178	133	62			•	
	107	60	43	•			
14,2	115	65	45	•			
	133	83	48		•		
	115	65	45	•			
14,5	133	83	63		•		
	203	152	122			•	
	115	65	45	•			
14,8	133	83	63		•		

14,8	16	203	152	122			
15		115	65	45	•		
		133	83	63		•	
15,2		203	152	122			•
		115	65	48	•		
15,3		133	83	48		•	
		115	65	48	•		
15,5		133	83	48		•	
		115	65	45	•		
15,7		133	83	63		•	
		115	65	48	•		
15,8		133	83	48		•	
		115	65	45	•		
16		203	152	122			•
	115	65	45	•			
16,3	133	83	63		•		
	203	152	122			•	
16,5	143	93	48		•		
	123	73	51	•			
16,8	143	93	71		•		
	222	171	150			•	
17	123	73	51	•			
	143	93	71		•		
17,5	222	171	150			•	
	123	73	51	•			
17,8	143	93	71		•		
	222	171	150			•	
18	123	73	51	•			
	143	93	71		•		
18,5	222	171	150			•	
	131	79	55	•			
19	153	101	77		•		
	243	190	170			•	
19,5	131	79	55	•			
	153	101	77		•		
20	243	190	170			•	
	131	79	55	•			
20	153	101	77		•		
	243	190	170			•	

Твердосплавные сверла



HRC 45-55

Система обозначений	
d1	диаметр режущей части, мм
Лобц	общая длина, мм
l2	длина рабочей части, мм
d2,h6	диаметр хвостовика, мм
tmax	максимальная глубина резания, мм

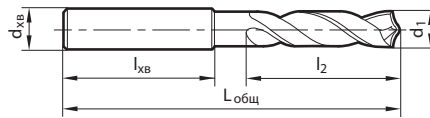

Глубина обработки		4xD			
Материал		VHM			
Покрытие		STB			
Угол при вершине		135°			
Группы обрабатываемых материалов. Основное применение		P			
		M			
		N			
		K			
		S			
H		•			
d1, h7	d2, h6	Лобц	l2	t max	Артикул
STD6410					
2,8	6	62	20	14	•
3					•
3,3					•
3,4					•
3,5					•
3,8		66	24	17	•
4					•
4,2					•
4,3					•
4,5					•
4,8	79	28	20	•	
5				•	
5,2				•	
5,5				•	
5,8				•	
6	8	34	24	•	
6,5				•	
6,8				•	
7				•	
7,2				•	
7,8	89	41	29	•	
8				•	
8,5				•	
8,7				•	
8,8				•	
9	10	47	35	•	
9,8				•	
10				•	

10,2	12	102	55	35	•
10,3					•
10,5					•
10,8					•
11					•
11,8	14	107	60	43	•
12					•
12,5					•
12,8					•
13					•
13,8	16	115	65	45	•
14					•
14,8					•
15					•
15,8					•
16	•				

Данная серия также доступна с исполнением хвостовика **НВ** и **НЕ**.
 Пример заказа с хвостовиком НВ: STD6410 d3 НВ
 Пример заказа с хвостовиком НЕ: STD6410 d3 НЕ

твердо-сплавные сверла

универсальное применение

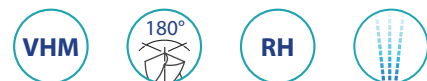

Система обозначений	
d1	диаметр режущей части, мм
Лобц	общая длина, мм
l2	длина рабочей части, мм
dxв	диаметр хвостовика, мм

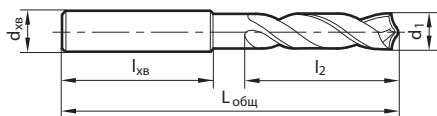

Глубина обработки		5xD		
Материал		VHM		
Покрытие		TiAlN		
Группы обрабатываемых материалов Основное применение	P	•		
	M	•		
	N	•		
	K	•		
	S	○		
H				
d1	dxв	Лобц	l2	Артикулы
STD3418				
3	6	66	28	•
3,1				•
3,2				•
3,3				•
3,4				•
3,5				•
3,6				•
3,7				•
3,8				•
3,9	•			
4	6	74	36	•
4,1				•
4,2				•
4,3				•
4,4				•
4,5				•
4,6				•
4,65				•
4,7				•
4,8				•
4,9	•			
5	6	82	44	•
5,1				•
5,2				•
5,3				•
5,4				•
5,5				•
5,55				•
5,6				•
5,7				•
5,8				•
5,9	•			
6	8	91	53	•
6,1				•
6,2				•
6,3				•
6,4				•
6,5				•
6,6				•
6,7				•
6,8				•
6,9				•

7	8	91	53	•
7,1				•
7,2				•
7,3				•
7,4				•
7,5				•
7,6				•
7,7				•
7,8				•
7,9				•
8	10	103	61	•
8,1				•
8,2				•
8,3				•
8,4				•
8,5				•
8,6				•
8,7				•
8,8				•
8,9				•
9	10	103	61	•
9,1				•
9,2				•
9,3				•
9,4				•
9,5				•
9,6				•
9,7				•
9,8				•
9,9				•
10	12	116	69	•
10,1				•
10,2				•
10,3				•
10,4				•
10,5				•
10,6				•
10,7				•
10,8				•
10,9				•
11	12	116	69	•
11,1				•
11,2				•
11,3				•
11,4				•
11,5				•
11,6				•
11,7				•
11,8				•
11,9				•
12	14	122	75	•
12,5				•
12,8				•
13				•
13,5				•
13,8				•
14				•
14,5				•
14,8				•
15				•
15	16	131	81	•
15,5				•
15,8				•
16				•
16,5				•
16,8				•
17				•
17,5				•
17,8				•
18				•
17	18	141	91	•
17,5				•
17,8				•
18				•
18,5				•
18,8				•
19				•
19,5				•
19,8				•
20				•
19	20	151	99	•
19,5				•
19,8				•
20				•

универсальное применение

Система обозначений	
d1	диаметр режущей части, мм
Лобц	общая длина, мм
l2	длина рабочей части, мм
dxв	Диаметр хвостовика, мм
lxв	длина хвостовика, мм
tmax	максимальная глубина резания, мм

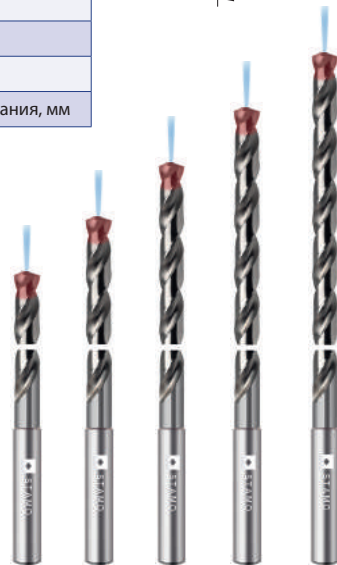
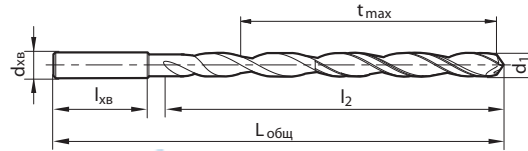

Глубина обработки		12xD	15xD	20xD	25xD	30xD	
Материал		VHM	VHM	VHM	VHM	VHM	
Покрытие		TiAlN	STV	STV	STV	STV	
Группы обрабатываемых материалов Основное применение	P	•	•	•	•	•	
	M	•	•	•	•	•	
	N	○	○	○	○	○	
	K	•	•	•	•	•	
	S	○	○	○	○	○	
	H	○	○	○	○	○	
d1	dxв	Лобц	l2	tmax	Артикулы		
STD3442 STD3452 STD3462 STD3472 STD3482							
1	3	55	15	12	•		
		75	18,2	18,2		•	
1,1	3	55	23	18,5	•		
		75	20,2	20,2		•	
1,2	3	55	23	18,5	•		
		75	24,2	24,2		•	
1,3	3	55	23	18,5	•		
		75	24,2	24,2		•	
1,4	3	55	23	18,5	•		
		75	27,2	27,2		•	
1,5	3	65	30	24	•		
		75	27,2	27,2		•	
1,6	3	65	30	24	•		
		75	30,2	30,2		•	
1,7	3	65	30	24	•		
		75	30,2	30,2		•	
1,8	3	65	30	24	•		
		75	35,2	35,2		•	
1,9	3	65	30	24	•		
		75	35,2	35,2		•	
2	4	74	38	30,5	•		
		80	35,5	35,5		•	
		95	45,5	45,5		•	
2,1	4	105	65,5	65,5		•	
		74	38	30,5	•		
		80	40,5	40,5		•	
2,2	4	95	50,5	50,5		•	
		74	38	30,5	•		
		80	40,5	40,5		•	
2,3	4	95	45,5	45,5		•	
		115	75,5	75,5		•	
		74	38	30,5	•		
2,3	4	80	40,5	40,5		•	
		95	55,5	55,5		•	
		115	73,5	73,5		•	

2,4	3	74	38	30,5	•			
	4	90	45,5	45,5		•		
2,5	4	95	55,5	55,5			•	
		130	85,5	85,5				•
		81	44	35	•			
2,5	4	90	45,5	45,5		•		
		108	60,5	60,5			•	
		130	85,5	85,5				•
2,6	4	81	44	35	•			
		90	48,5	48,5		•		
2,7	4	108	60,5	60,5			•	
		140	95,5	95,5				•
		81	44	35	•			
2,7	4	90	48,5	48,5		•		
		108	65,5	65,5			•	
		140	95,5	95,5				•
2,8	4	81	44	35	•			
		90	50,5	50,5		•		
		108	65,5	65,5			•	
2,8	4	140	95,5	95,5				•
		81	44	35	•			
		90	50,5	50,5		•		
2,9	4	112	68,5	68,5			•	
		140	95,5	95,5				•
		81	44	35	•			
3	6	92	54	48	•			
		100	55,5	55,5		•		
		112	68,5	68,5			•	
		130	85,5	85,5				•
3	6	150	105,5	105,5				•

универсальное применение

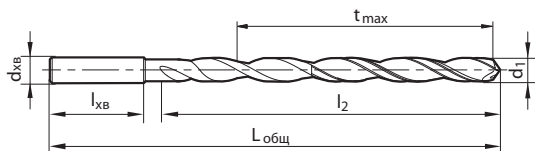

VHM

135°

RH

h7

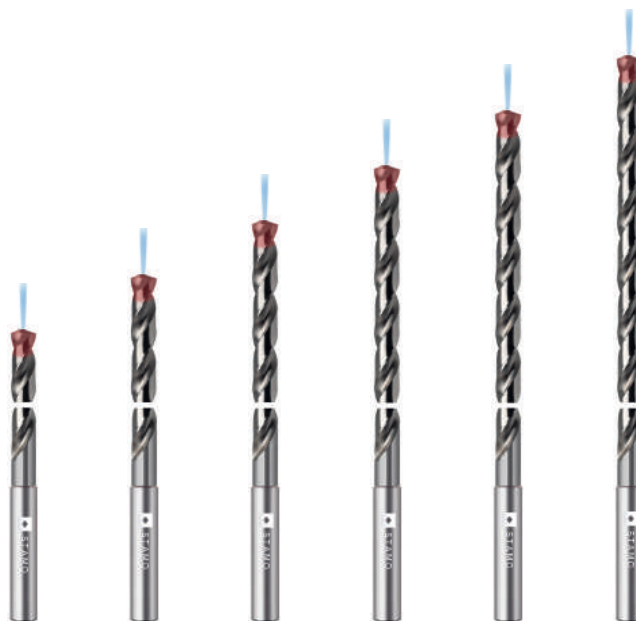

Система обозначений	
d1	диаметр режущей части, мм
Лобщ	общая длина, мм
l2	длина рабочей части, мм
dxв	Диаметр хвостовика, мм
lхв	длина хвостовика, мм
tmax	максимальная глубина резания, мм

твердо-сплавные сверла

Глубина обработки		12xD	15xD	20xD	25xD	30xD	40xD			
Материал		VHM	VHM	VHM	VHM	VHM	VHM			
Покрытие		TiAIN	STV	STV	STV	STV	AlTiN			
Группы обрабатываемых материалов Основное применение		P	•	•	•	•	•			
		M	•	•	•	•	•			
		N	○	○	○	○	○	○		
		K	•	•	•	•	•	•		
		S	○	○	○	○	○	○		
		H	○	○	○	○	○			
d1	dxв	Лобщ	l2	tmax	Артикулы					
					STD3442	STD3452	STD3462	STD3472	STD3482	STD3492
3	6	170	130	130						•
3,1	6	92	54	48	•					
		100	55,5	55,5		•				
3,17	6	193	153	153						•
		193	153	148,245						•
3,2	6	92	54	48	•					
		100	60,5	60,5		•				
		120	75,5	75,5				•		
		150	105,5	105,5					•	
3,3	6	92	54	48	•					
		100	60,5	60,5		•				
		120	75,5	75,5				•		
		140	95,5	95,5					•	
3,4	6	92	54	48	•					
		100	60,5	60,5		•				
		160	115,5	115,5					•	
3,5	6	92	54	48	•					
		108	65,5	65,5		•				
		130	80,5	80,5				•		
		150	100,5	100,5					•	
		193	153	153						•
3,57	6	216	176	170,645						•
3,6	6	92	54	48	•					
		108	65,5	65,5			•			
3,7	6	92	54	48	•					
		108	70,5	70,5			•			
3,8	6	102	64	58	•					
		108	70,5	70,5			•			
		140	90,5	90,5				•		
		150	105,5	105,5					•	
		175	125,5	125,5						•
		216	176	176						•

универсальное применение

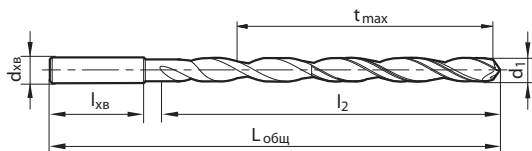

Система обозначений	
d1	диаметр режущей части, мм
Лобщ	общая длина, мм
l2	длина рабочей части, мм
dxв	Диаметр хвостовика, мм
lхв	длина хвостовика, мм
tmax	максимальная глубина резания, мм

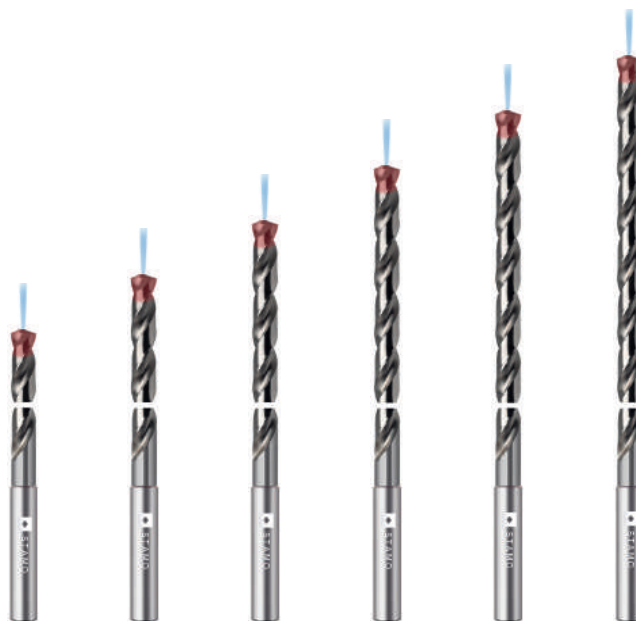

Глубина обработки		12xD	15xD	20xD	25xD	30xD	40xD			
Материал		VHM	VHM	VHM	VHM	VHM	VHM			
Покрытие		TiAIN	STV	STV	STV	STV	AlTiN			
Группы обрабатываемых материалов Основное применение	P	•	•	•	•	•	•			
	M	•	•	•	•	•	•			
	N	○	○	○	○	○	○			
	K	•	•	•	•	•	•			
	S	○	○	○	○	○	○			
	H	○	○	○	○	○	○			
d1	dxв	Лобщ	l2	tmax	Артикулы					
					STD3442	STD3452	STD3462	STD3472	STD3482	STD3492
3,9	6	102	64	58	•					
		108	70,5	70,5		•				
3,97	6	216	176	170,045						•
		102	64	58	•					
4	6	120	75,5	75,5		•				
		140	95,5	95,5			•			
		160	110,5	110,5				•		
		185	135,5	135,5					•	
		216	176	176						•
		102	64	58	•					
4,1	6	120	75,5	75,5		•				
		102	64	58	•					
		120	75,5	75,5		•				
		140	95,5	95,5			•			
		170	120,5	120,5				•		
		185	135,5	135,5					•	
4,2	6	238	198	198					•	•
		102	64	58	•					
		120	75,5	75,5		•				
		140	95,5	95,5			•			
		170	120,5	120,5				•		
		185	135,5	135,5					•	
4,3	6	102	64	58	•					
		120	80,5	80,5		•				
4,37	6	238	198	191,445					•	
4,4	6	102	64	58	•					
		120	80,5	80,5		•				
4,5	6	102	64	58	•					
		120	80,5	80,5		•				
		160	110,5	110,5			•			
		180	130,5	130,5				•		
		195	145,5	145,5					•	
		238	198	198						•
4,6	6	102	64	58	•					
		125	85,5	85,5		•				
		160	110,5	110,5			•			
		205	155,5	155,5					•	
4,7	6	102	64	58	•					
		125	85,5	85,5		•				
4,76	6	258	218	210,86						•

твердо-сплавные сверла

универсальное применение

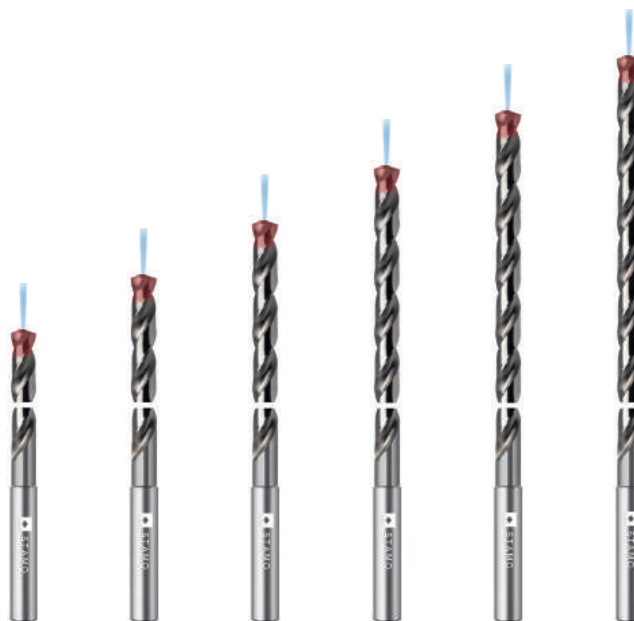
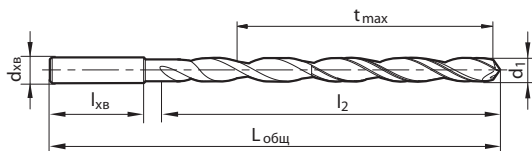

Система обозначений	
d1	диаметр режущей части, мм
Лобщ	общая длина, мм
l2	длина рабочей части, мм
dxв	Диаметр хвостовика, мм
lхв	длина хвостовика, мм
tmax	максимальная глубина резания, мм

твердо-сплавные сверла

Глубина обработки		12xD	15xD	20xD	25xD	30xD	40xD			
Материал		VHM	VHM	VHM	VHM	VHM	VHM			
Покрытие		TiAIN	STV	STV	STV	STV	AlTiN			
Группы обрабатываемых материалов Основное применение	P	•	•	•	•	•	•			
	M	•	•	•	•	•	•			
	N	○	○	○	○	○	○			
	K	•	•	•	•	•	•			
	S	○	○	○	○	○	○			
	H	○	○	○	○	○	○			
d1	dxв	Лобщ	l2	tmax	Артикулы					
					STD3442	STD3452	STD3462	STD3472	STD3482	STD3492
4,8	6	118	78	70	•					
		140	90,5	90,5		•				
		160	115,5	115,5				•		
		190	140,5	140,5					•	
4,9	6	210	165,5	165,5					•	
		118	78	70	•					
5	6	140	90,5	90,5		•				
		118	78	70	•					
		140	90,5	90,5		•				
		160	115,5	115,5				•		
		190	140,5	140,5					•	
		210	165,5	165,5						•
5,1	6	258	218	218						•
		118	78	70	•					
		140	95,5	95,5		•				
5,16	6	280	240	240						•
		280	240	232,26						•
5,2	6	118	78	70	•					
		140	95,5	95,5		•				
5,3	6	118	78	70	•					
		140	95,5	95,5		•				
5,4	6	118	78	70	•					
		140	95,5	95,5		•				
5,41	6	280	240	231,885						•
		118	78	70	•					
		150	100,5	100,5		•				
		185	140,5	140,5				•		
		210	160,5	160,5					•	
		240	180,5	180,5						•
5,56	6	280	240	240						•
		300	260	251,66						•
5,6	6	118	78	70	•					
		150	100,5	100,5		•				
5,7	6	118	78	70	•					
		150	100,5	100,5		•				

универсальное применение

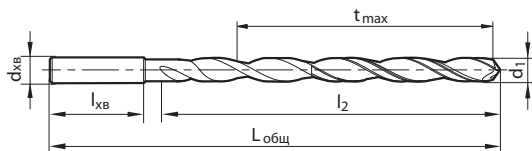

Система обозначений	
d1	диаметр режущей части, мм
Лобщ	общая длина, мм
l2	длина рабочей части, мм
dxв	Диаметр хвостовика, мм
lхв	длина хвостовика, мм
tmax	максимальная глубина резания, мм

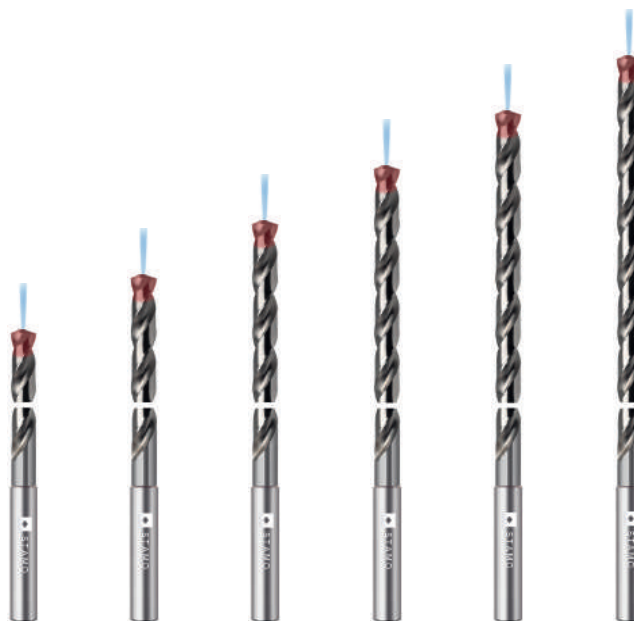

Глубина обработки		12xD	15xD	20xD	25xD	30xD	40xD			
Материал		VHM	VHM	VHM	VHM	VHM	VHM			
Покрытие		TiAIN	STV	STV	STV	STV	AlTiN			
Группы обрабатываемых материалов Основное применение	P	•	•	•	•	•	•			
	M	•	•	•	•	•	•			
	N	○	○	○	○	○	○			
	K	•	•	•	•	•	•			
	S	○	○	○	○	○	○			
	H	○	○	○	○	○	○			
d1	dxв	Лобщ	l2	tmax	Артикулы					
					STD3442	STD3452	STD3462	STD3472	STD3482	STD3492
5,8	6	118	78	70	•					
		150	100,5	100,5		•				
		185	140,5	140,5				•		
		210	160,5	160,5					•	
		240	190,5	190,5						•
5,9	6	118	78	70	•					
		150	100,5	100,5		•				
5,95	6	300	260	251,075						•
6	6	118	78	70	•					
		150	100,5	100,5		•				
		185	140,5	140,5				•		
		220	170,5	170,5					•	
		240	190,5	190,5						•
		300	260	260						
6,1	8	146	108	94	•					
		148	108	108		•				
6,2	8	146	108	94	•					
		148	108	108		•				
6,3	8	114	76	52						
		148	108	94	•					
		145	108	108		•				
6,35	8	322	260	260						•
		322	282	272,475						•
6,4	8	146	108	94	•					
		148	108	108		•				
6,5	8	146	108	94	•					
		160	121	121		•				
		190	150	150				•		
		230	191	191					•	
		260	222	222						•
		322	282	282						
6,6	8	146	108	94	•					
		160	121	121		•				
6,7	8	146	108	94	•					
		170	131	131		•				

твердо-сплавные сверла

универсальное применение

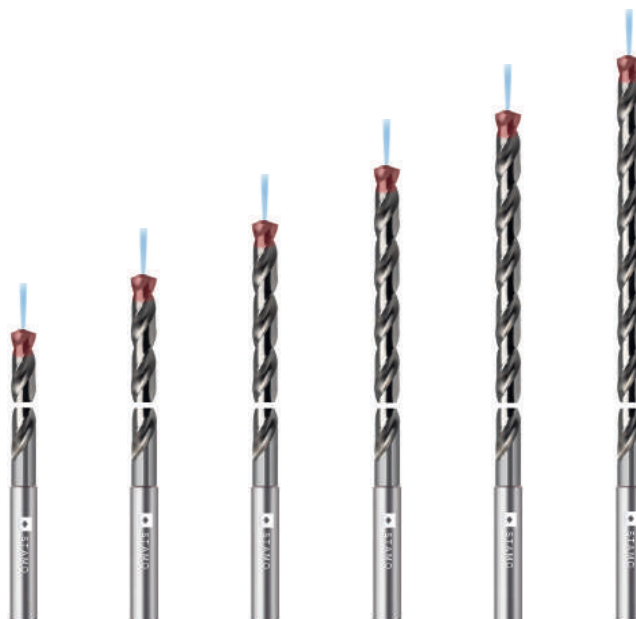
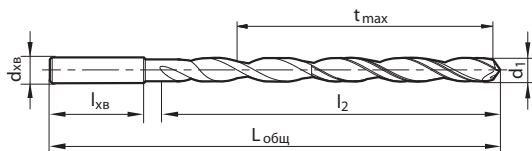

Система обозначений	
d1	диаметр режущей части, мм
Лобщ	общая длина, мм
l2	длина рабочей части, мм
dxв	Диаметр хвостовика, мм
lхв	длина хвостовика, мм
tmax	максимальная глубина резания, мм

Твердосплавные сверла

Глубина обработки		12xD	15xD	20xD	25xD	30xD	40xD			
Материал		VHM	VHM	VHM	VHM	VHM	VHM			
Покрытие		TiAIN	STV	STV	STV	STV	AlTiN			
Группы обрабатываемых материалов Основное применение		P	•	•	•	•	•			
		M	•	•	•	•	•			
		N	○	○	○	○	○	○		
		K	•	•	•	•	•	•		
		S	○	○	○	○	○	○		
		H	○	○	○	○	○			
d1	dxв	Лобщ	l2	tmax	Артикулы					
					STD3442	STD3452	STD3462	STD3472	STD3482	STD3492
6,75	8	342	302	291,875						•
6,8	8	146	108	94	•					
		170	131	131		•				
		200	160	160				•		
		230	191	191					•	
6,9	8	146	108	94	•					
		170	131	131		•				
7	8	146	108	94	•					
		170	131	131		•				
		210	170	170				•		
		240	201	201					•	
		270	232	232						•
342	302	302							•	
7,1	8	146	108	94	•					
7,14	8	363	323	312,29						•
7,2	8	146	108	94	•					
7,3	8	146	108	94	•					
7,4	8	146	108	94	•					
7,5	8	146	108	94	•					
		170	131	131		•				
		210	170	170				•		
		250	214	214					•	
		290	252	252						•
363	323	323							•	
7,54	8	383	343	331,69						•
7,6	8	146	108	94	•					
7,7	8	114	76	60						
		146	108	94	•					
7,8	8	146	108	94	•					
		180	141	141		•				
		230	190	190				•		
		260	224	224					•	
		300	262	262						•
7,9	8	146	108	94	•					

универсальное применение

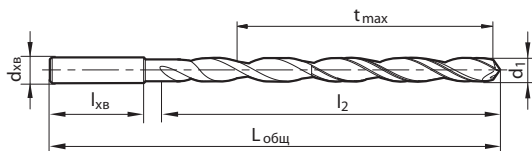

Система обозначений	
d1	диаметр режущей части, мм
Лобщ	общая длина, мм
l2	длина рабочей части, мм
dxв	Диаметр хвостовика, мм
lхв	длина хвостовика, мм
tmax	максимальная глубина резания, мм

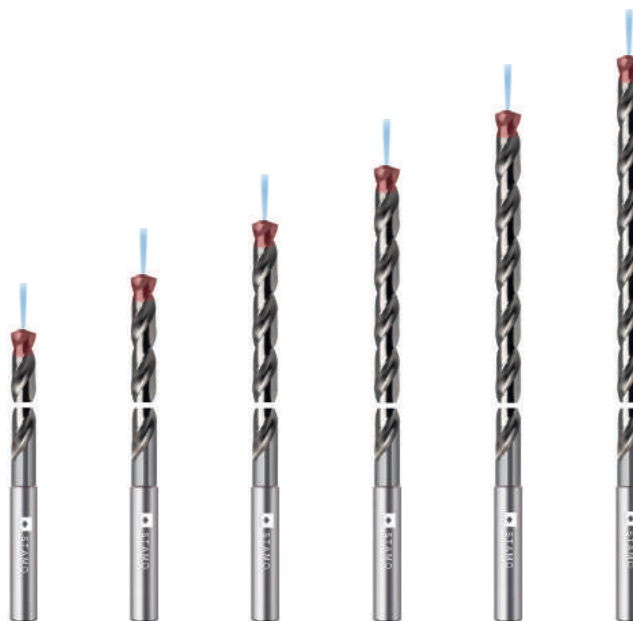

Глубина обработки		12xD	15xD	20xD	25xD	30xD	40xD			
Материал		VHM	VHM	VHM	VHM	VHM	VHM			
Покрытие		TiAIN	STV	STV	STV	STV	AlTiN			
Группы обрабатываемых материалов Основное применение	P	•	•	•	•	•	•			
	M	•	•	•	•	•	•			
	N	○	○	○	○	○	○			
	K	•	•	•	•	•	•			
	S	○	○	○	○	○	○			
	H	○	○	○	○	○	○			
d1	dxв	Лобщ	l2	tmax	Артикулы					
					STD3442	STD3452	STD3462	STD3472	STD3482	STD3492
7,94	8	383	343	331,09						•
8	8	146	108	94	•					
		180	141	141		•				
		230	190	190			•			
		260	224	224				•		
		305	267	267					•	
		383	343	343						•
8,1	10	162	120	110	•					
8,2	10	162	120	110	•					
8,3	10	162	120	110	•					
8,4	10	162	120	110	•					
8,5	10	162	120	110	•					
		198	155	155		•				
		240	196	196			•			
		280	237	237				•		
		320	278	278				•		
8,6	10	162	120	110	•					
8,7	10	142	95	68						
		162	120	110	•					
8,8	10	162	120	110	•					
		208	165	165		•				
		290	247	247			•			
		310	270	270				•		
		340	298	298				•		
8,9	10	162	120	110	•					
9	10	162	120	110	•					
		208	165	165		•				
		260	216	216			•			
		290	247	247				•		
		340	298	298				•		
9,1	10	162	120	110	•					
9,2	10	142	95	76						
		162	120	110	•					
9,3	10	162	120	110	•					
9,4	10	162	120	110	•					

твердо-сплавные сверла



универсальное применение

Система обозначений	
d1	диаметр режущей части, мм
Лобц	общая длина, мм
l2	длина рабочей части, мм
dхв	Диаметр хвостовика, мм
lхв	длина хвостовика, мм
tmax	максимальная глубина резания, мм

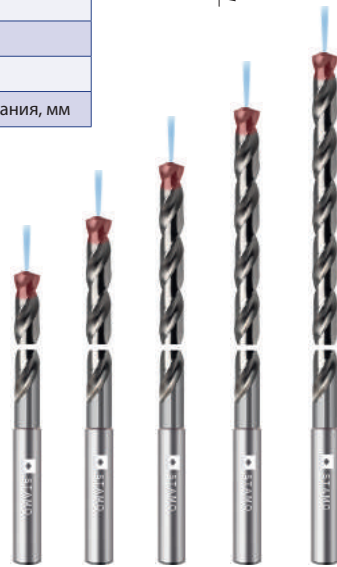
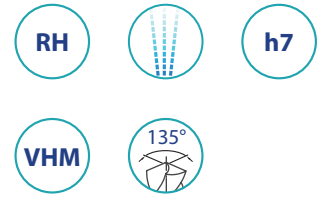
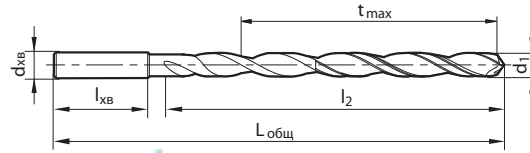

Глубина обработки		12xD	15xD	20xD	25xD	30xD			
Материал		VHM	VHM	VHM	VHM	VHM			
Покрытие		TiAlN	STV	STV	STV	STV			
Группы обрабатываемых материалов	P	•	•	•	•	•			
	M	•	•	•	•	•			
	N	○	○	○	○	○			
	K	•	•	•	•	•			
	S	○	○	○	○	○			
Основное применение		H	○	○	○	○			
d1	dXB	Лобц	l2	tmax	Артикулы				
				STD3442		STD3452	STD3462	STD3472	STD3482
9,5	10	162	120	110	•				
		208	165	165		•			
		310	267	267				•	
		360	318	318					•
9,6	10	162	120	110	•				
9,7	10	162	120	110	•				
9,8	10	162	120	110	•				
		208	165	165		•			
		280	236	236			•		
		310	267	267				•	
		380	338	338					•
9,9	10	162	120	110	•				
		162	120	110	•				
10	10	218	175	175		•			
		280	236	236			•		
		310	267	267				•	
		380	338	338					•
10,1	12	204	156	142	•				
		204	156	142	•				
10,2	12	235	187	187		•			
		290	241	241			•		
		340	292	292				•	
		204	156	142	•				
10,3	12	204	156	142	•				
10,4	12	204	156	142	•				
		204	156	142	•				
10,5	12	245	197	197		•			
		204	156	142	•				
10,6	12	204	156	142	•				
		204	156	142	•				
		204	156	142	•				
		204	156	142	•				
		204	156	142	•				
10,7	12	204	156	142	•				
		204	156	142	•				
		245	197	197		•			
		204	156	142	•				
10,8	12	204	156	142	•				
		245	197	197		•			
		315	266	266			•		
		350	302	302				•	
		204	156	142	•				
10,9	12	204	156	142	•				
		204	156	142	•				
11	12	204	156	142	•				
		245	197	197		•			

11,1	12	204	156	142	•				
11,2	12	204	156	142	•				
		245	197	197		•			
11,3	12	204	156	142	•				
11,4	12	204	156	142	•				
11,5	12	204	156	142	•				
		245	197	197		•			
11,6	12	204	156	142	•				
11,7	12	204	156	142	•				
11,8	12	204	156	142	•				
		255	207	207		•			
		315	266	266			•		
		375	327	327				•	
11,9	12	204	156	142	•				
12	12	204	156	142	•				
		255	207	207		•			
		315	266	266			•		
		375	327	327				•	
12,5	14	230	182	166	•				
12,8	14	230	182	166	•				
13	14	230	182	166	•				
13,5	14	230	182	166	•				
13,8	14	230	182	166	•				
14	14	230	182	166	•				
14,5	16	260	208	192	•				
14,8	16	260	208	192	•				
15	16	260	208	192	•				
15,5	16	260	208	192	•				
15,8	16	260	208	192	•				
16	16	208	260	192	•				
16,5	18	234	285	216	•				
16,8	18	234	285	216	•				
17	18	234	285	216	•				
17,5	18	234	285	216	•				
17,8	18	234	285	216	•				
18	18	234	285	216	•				
18,5	20	258	310	238	•				
18,8	20	258	310	238	•				
19	20	258	310	238	•				
19,5	20	258	310	238	•				
19,8	20	258	310	238	•				
20	20	258	310	238	•				

МИКРОСВЕРЛА



мікро
сверла

универсальное применение

Система обозначений	
d1	диаметр режущей части, мм
Лобщ	общая длина, мм
l2	длина рабочей части, мм
dxв	диаметр хвостовика, мм
lxв	длина хвостовика, мм

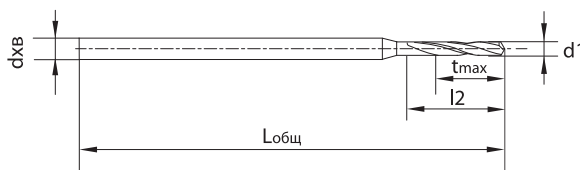

Глубина обработки		5xD	5xD				
Материал		HSSE-PM	HSSE-PM				
Покрытие		BR	TiN				
Группы обрабатываемых материалов	P	•	•				
	M	•	•				
	N	•	•				
	K	•	•				
	S	○	○				
	H						
Основное применение							
d1	dxв	Лобщ	l2	tmax	Артикулы		
					STD1320	STD2320	
0,05	1	25	0,4	0,325	•		
0,06				0,31	•		
0,08				0,38	•		
0,09				0,365	•		
0,1				0,5	0,35	•	
0,11					0,335	•	
0,12			0,32		•		
0,13			0,8	0,605	•		
0,14				0,59	•		
0,15				0,575	•		
0,16				0,86	•		
0,17				1,1	0,845	•	
0,18					0,83	•	
0,19			0,815		•		
0,2			1,5	1,2	•	•	
0,205				1,1925	•		
0,21				1,185	•		
0,215				1,1775	•		
0,22				1,17	•		
0,225				1,1625	•		
0,23				1,155	•		
0,235				1,1475	•		
0,24				1,14	•		
0,245				1,5325	•		
0,25				1,525	•		
0,255				1,5175	•		
0,26			1,9	1,51	•		
0,265				1,5025	•		
0,27				1,495	•		
0,275				1,4875	•		
0,28	1,48	•					
0,285	1,4725	•					

0,29	1	25	1,9	1,465	•	
0,295				1,4575	•	
0,3				1,45	•	•
0,31				1,935	•	
0,315				1,9275	•	
0,32				1,92	•	
0,325			1,9125	•		
0,33			1,905	•		
0,335			1,8975	•		
0,34			1,89	•		
0,345			1,8825	•		
0,35			1,875	•	•	
0,355			1,8675	•		
0,36			1,86	•		
0,365			1,8525	•		
0,37			1,845	•		
0,375			1,8375	•		
0,38			1,83	•		
0,385			2,4225	•		
0,39			2,415	•		
0,4			2,4	•	•	
0,405			2,3925	•		
0,41			2,385	•		
0,415			2,3775	•		
0,42			2,37	•		
0,425			2,3625	•		
0,43			2,355	•		
0,435			2,3475	•		
0,44			2,34	•		
0,45			2,325	•	•	
0,46	2,31	•				
0,47	2,295	•				
0,48	2,28	•				
0,485	2,6725	•				
0,49	2,665	•	•			
0,495	2,6575	•				
0,5	2,65	•	•			
0,505	2,6425	•				
0,51	2,635	•	•			
0,515	2,6275	•				
0,52	2,62	•	•			
0,525	2,6125	•				
0,53	2,605	•				
0,535	3,0975	•				
0,54	3,09	•				
0,55	3,075	•				
0,555	3,0675	•				
0,56	3,06	•				
0,57	3,045	•				
0,575	3,0375	•				
0,58	3,03	•				
0,585	3,0225	•				
0,59	3,015	•	•			
0,595	3,0075	•				
0,6	3	•	•			
0,605	3,2925	•				
0,61	3,285	•				
0,615	3,2775	•				
0,62	3,27	•				
0,625	3,2625	•				
0,63	3,255	•				

универсальное применение

Система обозначений	
d1	диаметр режущей части, мм
Лобц	общая длина, мм
l2	длина рабочей части, мм
dxв	диаметр хвостовика, мм
lхв	длина хвостовика, мм

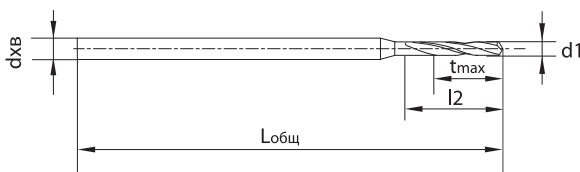

Глубина обработки		5xD	5xD			
Материал		HSSE-PM	HSSE-PM			
Покрытие		BR	TIN			
Группы обрабатываемых материалов	P	•	•			
	M	•	•			
	N	•	•			
	K	•	•			
	S	○	○			
Основное применение						
d1	dxв	Лобц	l2	tmax	Артикулы	
					STD1320	STD2320
0,64	1	25	4,2	3,24	•	
0,65				3,225	•	
0,66				3,21	•	
0,665				3,2025	•	
0,67				3,195	•	
0,68			3,78	•		
0,69			3,765	•		
0,695			3,7575	•		
0,7			3,75	•	•	
0,705			3,7425	•		
0,71			3,735	•		
0,72			3,72	•		
0,73			3,705	•		
0,74			3,69	•		
0,75			3,675	•		
0,76			4,16	•	•	
0,77			4,145	•		
0,78			4,13	•		
0,79			4,115	•		
0,8			4,1	•	•	
0,81			4,085	•		
0,82			4,07	•		
0,83			4,055	•		
0,84			4,04	•		
0,85			4,025	•		
0,86	4,71	•				
0,87	4,695	•				
0,88	4,68	•	•			
0,89	4,665	•				
0,9	4,65	•	•			
0,91	4,635	•				
0,92	4,62	•	•			

0,93	1,5	25	6	4,605	•	
0,94				4,59	•	•
0,95				4,575	•	
0,96				5,36	•	
0,97				5,345	•	
0,98			5,33	•	•	
0,99			5,315	•		
1			5,3	•	•	
1,01			5,285	•		
1,02			5,27	•		
1,03			5,255	•		
1,04			5,24	•		
1,05			5,225	•	•	
1,06			5,21	•		
1,07			5,995	•		
1,08			5,98	•		
1,1			5,95	•	•	
1,11			5,935	•		
1,12			5,92	•		
1,14			5,89	•		
1,15			5,875	•	•	
1,16			5,86	•		
1,17			5,845	•		
1,18			5,83	•		
1,19			6,715	•		
1,2	6,7	•	•			
1,21	6,685	•				
1,22	6,67	•				
1,23	6,655	•				
1,24	6,64	•				
1,25	6,625	•	•			
1,26	6,61	•				
1,27	6,595	•				
1,28	6,58	•				
1,29	6,565	•				
1,3	6,55	•	•			
1,31	6,535	•				
1,32	6,52	•				
1,34	7,49	•				
1,35	7,475	•				
1,38	7,43	•				
1,39	7,415	•				
1,4	7,4	•	•			
1,41	7,385	•				
1,42	7,37	•				
1,43	7,355	•				
1,44	7,34	•				
1,45	7,325	•	•			
1,5	7,25	•				
1,6	8,2	•				
1,63	8,155	•				
1,7	8,05	•				
1,8	9,1	•				
1,85	9,025	•				
1,9	8,95	•				

универсальное применение

Система обозначений	
d1	диаметр режущей части, мм
dxв	диаметр хвостовика, мм
Лобц	общая длина, мм
l2	длина обניжения, мм
d2	диаметр шейки, мм
tmax	максимальная глубина резания, мм

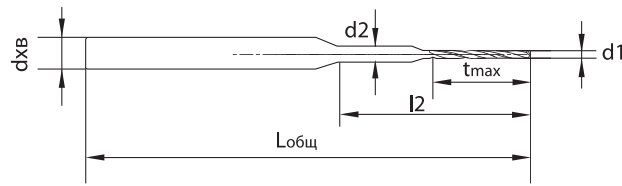

0,24	3	1	5	38	2,25		•	
			7		2			•
			3		0,75	•		
0,25	3	1	5	38	2,25		•	
			7		2			•
0,26	3	1	5	38	2,25		•	
			7		2,4			•
0,27	3	1	5	38	2,25		•	
			7		2,4			•
0,28	3	1	5	38	2,25		•	
			7		2,4			•
0,29	3	1	5	38	2,25		•	
			7		2,4			•
			3		0,9	•		
0,3	3	1	5	38	2,25		•	
			7		2,4			•
0,31	3	1	5	38	2,25		•	
			7		2,8			•
0,32	3	1	5	38	2,25		•	
			7		2,8			•
0,33	3	1	5	38	2,25		•	
			7		2,8			•
0,34	3	1	5	38	2,25		•	
			7		2,8			•
			3		1,05	•		
0,35	3	1	5	38	2,25		•	
			7		2,8			•
0,36	3	1	5	38	2,25		•	
			7		3,2			•
0,37	3	1	5	38	2,25		•	
			7		3,2			•
0,38	3	1	5	38	2,25		•	
			7		3,2			•
0,39	3	1	5	38	2,25		•	
			7		3,2			•
			3		1,2	•		
0,4	3	1	5	38	2,25		•	
			7		3,2			•
0,41	3	1	5	38	2,25		•	
			7		3,6			•
0,42	3	1	5	38	2,25		•	
			7		3,6			•
0,43	3	1	5	38	2,25		•	
			7		3,6			•
0,44	3	1	5	38	2,25		•	
			7		3,6			•
			3		1,35	•		
0,45	3	1	5	38	2,25		•	
			7		3,6			•
0,46	3	1	5	38	2,25		•	
			7		4			•
0,47	3	1	5	38	2,25		•	
			7		4			•
0,48	3	1	5	38	2,25		•	
			7		4			•
0,49	3	1	5	38	2,25		•	
			7		4			•
			6		1,5	•		
0,5	3	1,5	10	38	2,5		•	
			15		4			•
0,51	3	1,5	10	38	3		•	
			15		4,8			•

Глубина обработки	3xD	5xD	8xD					
Материал	VHM	VHM	VHM					
Покрытие	(BR)	(BR)	(BR)					
Группы обрабатываемых материалов Основное применение	P	•	•					
	M	•	•					
	N	•	•					
	K	•	•					
	S	○	○					
H								
d1	dxв	d2	l2	Лобц	tmax	STD3610 STD3620 STD3640		
0,1	3	1	3	38	0,3	•		
			5		0,5		•	
					0,8			•
0,11	3	1	5	38	0,6		•	
					1			•
0,12	3	1	5	38	0,7		•	
					1			•
0,13	3	1	5	38	0,8		•	
					1,2			•
0,14	3	1	5	38	0,9		•	
					1,2			•
0,15	3	1	5	38	0,45	•		
					1		•	
					1,3			•
0,16	3	1	5	38	1,25		•	
					1,3			•
0,17	3	1	5	38	1,5		•	
			5		1,5			•
			5		1,75		•	
0,18	3	1	5	38	1,5			•
					2		•	
0,19	3	1	5	38	1,6			•
			5		0,6	•		
			5		2,25		•	
0,2	3	1	3	38	1,6			•
			5		2,25		•	
			7		2,25		•	
0,21	3	1	5	38	2			•
			7		2,25		•	
0,22	3	1	5	38	2			•
			7		2,25		•	
0,23	3	1	5	38	2,25		•	
			7		2		•	

универсальное применение

Система обозначений	
d1	диаметр режущей части, мм
dxв	диаметр хвостовика, мм
Лобц	общая длина, мм
l2	длина обניжения, мм
d2	диаметр шейки, мм
tmax	максимальная глубина резания, мм

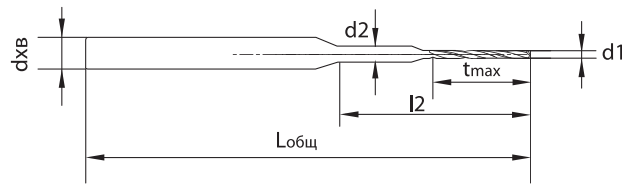

Глубина обработки		3xD	5xD	8xD				
Материал		VHM	VHM	VHM				
Покрытие		(BR)	(BR)	(BR)				
Группы обрабатываемых материалов	P	•	•	•				
	M	•	•	•				
	N	•	•	•				
	K	•	•	•				
	S	○	○	○				
Основное применение		H						
d1	dxв	d2	l2	Лобц	tmax			
						STD3610	STD3620	STD3640
0,52	3	1,5	10	38	3		•	
			15		4,8		•	
0,53	3	1,5	10	38	3		•	
			15		4,8		•	
0,54	3	1,5	10	38	3		•	
			15		4,8		•	
0,55	3	1,5	6	38	1,8	•		
			10		3		•	
			15		4,8		•	
0,56	3	1,5	10	38	3		•	
			15		4,8		•	
0,57	3	1,5	10	38	3		•	
			15		4,8		•	
0,58	3	1,5	10	38	3		•	
			15		4,8		•	
0,59	3	1,5	10	38	3		•	
			15		4,8		•	
0,6	3	1,5	6	38	1,8	•		
			10		3		•	
			15		4,8		•	
0,61	3	1,5	10	38	3,5		•	
			15		5,6		•	
0,62	3	1,5	10	38	3,5		•	
			15		5,6		•	
0,63	3	1,5	10	38	3,5		•	
			15		5,6		•	
0,64	3	1,5	10	38	3,5		•	
			15		5,6		•	
0,65	3	1,5	6	38	2,1	•		
			10		3,5		•	
			15		5,6		•	

0,66	3	1,5	10	38	3,5		•	
			15		5,6		•	
0,67	3	1,5	15	38	5,6		•	
			10		3,5		•	
0,68	3	1,5	15	38	5,6		•	
			10		3,5		•	
0,69	3	1,5	15	38	5,6		•	
			10		3,5		•	
0,7	3	1,5	6	38	2,1	•		
			10		3,5		•	
			15		5,6		•	
0,71	3	1,5	10	38	4		•	
			15		6,4		•	
0,72	3	1,5	10	38	4		•	
			15		6,4		•	
0,73	3	1,5	10	38	4		•	
			15		6,4		•	
0,74	3	1,5	10	38	4		•	
			15		6,4		•	
			6		2,4	•		
0,75	3	1,5	10	38	4		•	
			15		6,4		•	
0,76	3	1,5	10	38	4		•	
			15		6,4		•	
0,77	3	1,5	10	38	4		•	
			15		6,4		•	
0,78	3	1,5	10	38	4		•	
			15		6,4		•	
0,79	3	1,5	10	38	4		•	
			15		6,4		•	
0,8	3	1,5	6	38	2,4	•		
			10		4		•	
			15		6,4		•	
0,81	3	1,5	10	38	4,5		•	
			15		7,2		•	
0,82	3	1,5	10	38	4,5		•	
			15		7,2		•	
0,83	3	1,5	10	38	4,5		•	
			15		7,2		•	
0,84	3	1,5	10	38	4,5		•	
			15		7,2		•	
0,85	3	1,5	6	38	2,7	•		
			10		4,5		•	
			15		7,2		•	
0,86	3	1,5	10	38	4,5		•	
			15		7,2		•	
0,87	3	1,5	10	38	4,5		•	
			15		7,2		•	
0,88	3	1,5	10	38	4,5		•	
			15		7,2		•	
0,89	3	1,5	10	38	4,5		•	
			15		7,2		•	
0,9	3	1,5	6	38	2,7	•		
			10		4,5		•	
			15		7,2		•	
0,91	3	1,5	10	38	5		•	
			15		8		•	
0,92	3	1,5	10	38	5		•	
			15		8		•	
0,93	3	1,5	10	38	5		•	
			15		8		•	

микро сверла

универсальное применение

Система обозначений	
d1	диаметр режущей части, мм
dxв	диаметр хвостовика, мм
Лобц	общая длина, мм
l2	длина обניжения, мм
d2	диаметр шейки, мм
tmax	максимальная глубина резания, мм

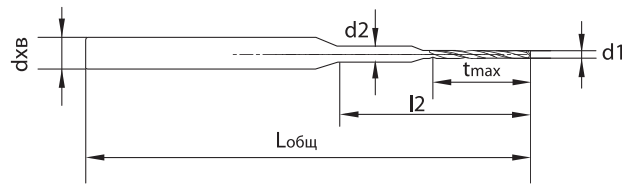

1,08	3	2	10	38	5,5		•	
			15		8,8			•
1,09	3	2	10	38	5,5		•	
			15		8,8			•
1,1	3	2	6		3,3	•		
			10	38	5,5		•	
			15		8,8			•
1,11	3	2	10	38	6		•	
			15		9,6			•
1,12	3	2	10	38	6		•	
			15		9,6			•
1,13	3	2	10	38	6		•	
			15		9,6			•
1,14	3	2	10	38	6		•	
			15		9,6			•
1,15	3	2	6		3,6	•		
			10	38	6		•	
			15		9,6			•
1,16	3	2	10	38	6		•	
			15		9,6			•
1,17	3	2	10	38	6		•	
			15		9,6			•
1,18	3	2	10	38	6		•	
			15		9,6			•
1,19	3	2	10	38	6		•	
			15		9,6			•
1,2	3	2	6		3,6	•		
			10	38	6		•	
			15		9,6			•
1,21	3	2	10	38	6		•	
			15		10,4			•
1,22	3	2	10	38	6		•	
			15		10,4			•
1,23	3	2	10	38	6		•	
			15		10,4			•
1,24	3	2	10	38	6		•	
			15		10,4			•
1,25	3	2	6		3,9	•		
			10	38	6		•	
			15		10,4			•
1,26	3	2	10	38	6		•	
			15		10,4			•
1,27	3	2	10	38	6		•	
			15		10,4			•
1,28	3	2	10	38	6		•	
			15		10,4			•
1,29	3	2	10	38	6		•	
			15		10,4			•
1,3	3	2	6		3,9	•		
			10	38	6		•	
			15		10,4			•
1,31	3	2	10	38	7		•	
			15		11,2			•
1,32	3	2	10	38	7		•	
			15		11,2			•
1,33	3	2	10	38	7		•	
			15		11,2			•
1,34	3	2	10	38	7		•	
			15		11,2			•
1,35	3	2	6		4,2	•		
			10	38	7		•	
			15		11,2			•

Глубина обработки		3xD	5xD	8xD				
Материал		VHM	VHM	VHM				
Покрытие		(BR)	(BR)	(BR)				
Группы обрабатываемых материалов	P	•	•	•				
	M	•	•	•				
	N	•	•	•				
	K	•	•	•				
	S	○	○	○				
Основное применение								
	H							
d1	dxв	d2	l2	Лобц	tmax			
						STD3610	STD3620	STD3640
0,94	3	1,5	10	38	5		•	
			15		8			•
0,95	3	1,5	6		3	•		
			10	38	5		•	
			15		8			•
0,96	3	1,5	10	38	5		•	
			15		8			•
0,97	3	1,5	10	38	5		•	
			15		8			•
0,98	3	1,5	10	38	5		•	
			15		8			•
0,99	3	1,5	10	38	5		•	
			15		8			•
1	3	1,5	6		3	•		
			10	38	5		•	
			15		8			•
1,01	3	2	10	38	5,5		•	
			15		8,8			•
1,02	3	2	10	38	5,5		•	
			15		8,8			•
1,03	3	2	10	38	5,5		•	
			15		8,8			•
1,04	3	2	10	38	5,5		•	
			15		8,8			•
1,05	3	2	6		3,3	•		
			10	38	5,5		•	
			15		8,8			•
1,06	3	2	10	38	5,5		•	
			15		8,8			•
1,07	3	2	10	38	5,5		•	
			15		8,8			•

универсальное применение

Система обозначений	
d1	диаметр режущей части, мм
dxв	диаметр хвостовика, мм
Лобц	общая длина, мм
l2	длина обнижения, мм
d2	диаметр шейки, мм
tmax	максимальная глубина резания, мм

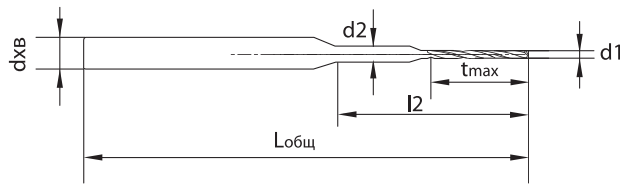

Глубина обработки	3xD	5xD	8xD					
Материал	VHM	VHM	VHM					
Покрытие	(BR)	(BR)	(BR)					
Группы обрабатываемых материалов Основное применение	P	•	•	•				
	M	•	•	•				
	N	•	•	•				
	K	•	•	•				
	S	○	○	○				
H								
d1	dxв	d2	l2	Лобц	tmax			
						STD3610	STD3620	STD3640
1,36	3	2	10	38	7		•	
			15		11,2			•
1,37	3	2	10	38	7		•	
			15		11,2			•
1,38	3	2	10	38	7		•	
			15		11,2			•
1,39	3	2	10	38	7		•	
			15		11,2			•
1,4	3	2	6	38	4,2	•		
			10		7		•	
			15		11,2			•
1,41	3	2	10	38	7,5		•	
			15		12			•
1,42	3	2	10	38	7,5		•	
			15		12			•
1,43	3	2	10	38	7,5		•	
			15		12			•
1,44	3	2	10	38	7,5		•	
			15		12			•
1,45	3	2	6	38	4,5	•		
			10		7,5		•	
			15		12			•
1,46	3	2	10	38	7,5		•	
			15		12			•
1,47	3	2	10	38	7,5		•	
			15		12			•
1,48	3	2	10	38	7,5		•	
			15		12			•
1,49	3	2	10	38	7,5		•	
			15		12			•

1,5	3	2	-	38	4,5	•		
			-		7,5		•	
			-		12			•
1,51	3	-	-	38	8		•	
			-		12,8			•
1,52	3	-	-	38	8		•	
			-		12,8			•
1,53	3	-	-	38	8		•	
			-		12,8			•
1,54	3	-	-	38	8		•	
			-		12,8			•
1,55	3	-	-	38	4,8	•		
			-		8		•	
			-		12,8			•
1,56	3	-	-	38	8		•	
			-		12,8			•
1,57	3	-	-	38	8		•	
			-		12,8			•
1,58	3	-	-	38	8		•	
			-		12,8			•
1,59	3	-	-	38	8		•	
			-		12,8			•
			-		4,8	•		
1,6	3	-	-	38	8		•	
			-		12,8			•
			-		8,5		•	
1,61	3	-	-	38	13,6			•
			-		8,5		•	
1,62	3	-	-	38	13,6			•
			-		8,5		•	
1,63	3	-	-	38	8,5		•	
			-		13,6			•
1,64	3	-	-	38	8,5		•	
			-		13,6			•
1,65	3	-	-	38	5,1	•		
			-		8,5		•	
1,66	3	-	-	38	13,6			•
			-		8,5		•	
1,67	3	-	-	38	8,5		•	
			-		13,6			•
1,68	3	-	-	38	8,5		•	
			-		13,6			•
1,69	3	-	-	38	8,5		•	
			-		13,6			•
1,7	3	-	-	38	5,1	•		
			-		8,5		•	
			-		13,6			•
1,71	3	-	-	38	9		•	
			-		14,4			•
1,72	3	-	-	38	9		•	
			-		14,4			•
1,73	3	-	-	38	9		•	
			-		14,4			•
1,74	3	-	-	38	9		•	
			-		14,4			•
1,75	3	-	-	38	5,4	•		
			-		9		•	
			-		14,4			•
1,76	3	-	-	38	9		•	
			-		14,4			•
1,77	3	-	-	38	9		•	
			-		14,4			•

микро сверла

универсальное применение

Система обозначений	
d1	диаметр режущей части, мм
dxв	диаметр хвостовика, мм
Лобц	общая длина, мм
l2	длина обניжения, мм
d2	диаметр шейки, мм
tmax	максимальная глубина резания, мм

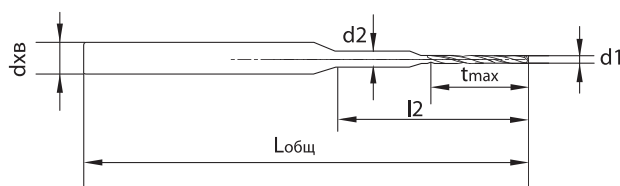

1,92	3	-	-	38	10			•	
		-	-	38	16				•
1,93	3	-	-	38	10			•	
		-	-	38	16				•
1,94	3	-	-	38	10			•	
		-	-	38	16				•
1,95	3	-	-	38	10		•		
		-	-	38	16				•
1,96	3	-	-	38	10			•	
		-	-	38	16				•
1,97	3	-	-	38	10			•	
		-	-	38	16				•
1,98	3	-	-	38	10			•	
		-	-	38	16				•
1,99	3	-	-	38	10			•	
		-	-	38	16				•
		-	-	38	6		•		
2	3	-	-	38	10			•	
		-	-	38	16				•
		-	-	38	16				•
2,01	3	-	-	38	10,5			•	
		-	-	38	16,8				•
2,02	3	-	-	38	10,5			•	
		-	-	38	16,8				•
2,03	3	-	-	38	10,5			•	
		-	-	38	16,8				•
2,04	3	-	-	38	10,5			•	
		-	-	38	16,8				•
		-	-	38	6,3		•		
2,05	3	-	-	38	10,5			•	
		-	-	38	16,8				•
2,06	3	-	-	38	10,5			•	
2,07	3	-	-	38	10,5			•	
2,08	3	-	-	38	10,5			•	
2,09	3	-	-	38	10,5			•	
2,1	3	-	-	38	6,3		•		
		-	-	38	10,5			•	
2,11	3	-	-	38	11			•	
2,12	3	-	-	38	11			•	
2,13	3	-	-	38	11			•	
2,14	3	-	-	38	11			•	
2,15	3	-	-	38	6,6		•		
		-	-	38	11			•	
2,16	3	-	-	38	11			•	
2,17	3	-	-	38	11			•	
2,18	3	-	-	38	11			•	
2,19	3	-	-	38	11			•	
2,2	3	-	-	38	6,6		•		
		-	-	38	11			•	
2,21	3	-	-	38	11,5			•	
2,22	3	-	-	38	11,5			•	
2,23	3	-	-	38	11,5			•	
2,24	3	-	-	38	11,5			•	
2,25	3	-	-	38	6,9		•		
		-	-	38	11,5			•	
2,26	3	-	-	38	11,5			•	
2,27	3	-	-	38	11,5			•	
2,28	3	-	-	38	11,5			•	
2,29	3	-	-	38	11,5			•	
2,3	3	-	-	38	6,9		•		
		-	-	38	11,5			•	
2,31	3	-	-	38	12			•	

Глубина обработки		3xD	5xD	8xD					
Материал		VHM	VHM	VHM					
Покрытие		(BR)	(BR)	(BR)					
Группы обрабатываемых материалов Основное применение	P	•	•	•					
	M	•	•	•					
	N	•	•	•					
	K	•	•	•					
	S	○	○	○					
	H								
d1	dxв	d2	l2	Лобц	tmax	STD3610 STD3620 STD3640			
1,78	3	-	-	38	9			•	
		-	-	38	14,4				•
1,79	3	-	-	38	9			•	
		-	-	38	14,4				•
1,8	3	-	-	38	5,4	•			
		-	-	38	9			•	
		-	-	38	14,4				•
1,81	3	-	-	38	9,5			•	
		-	-	38	15,2				•
1,82	3	-	-	38	9,5			•	
		-	-	38	15,2				•
1,83	3	-	-	38	9,5			•	
		-	-	38	15,2				•
1,84	3	-	-	38	9,5			•	
		-	-	38	15,2				•
1,85	3	-	-	38	5,7	•			
		-	-	38	9,5			•	
		-	-	38	15,2				•
1,86	3	-	-	38	9,5			•	
		-	-	38	15,2				•
1,87	3	-	-	38	9,5			•	
		-	-	38	15,2				•
1,88	3	-	-	38	9,5			•	
		-	-	38	15,2				•
1,89	3	-	-	38	9,5			•	
		-	-	38	15,2				•
1,9	3	-	-	38	5,7	•			
		-	-	38	9,5			•	
		-	-	38	15,2				•
1,91	3	-	-	38	10			•	
		-	-	38	16				•

универсальное применение

Система обозначений	
d1	диаметр режущей части, мм
dxв	диаметр хвостовика, мм
Лобц	общая длина, мм
l2	длина обнижения, мм
d2	диаметр шейки, мм
tmax	максимальная глубина резания, мм

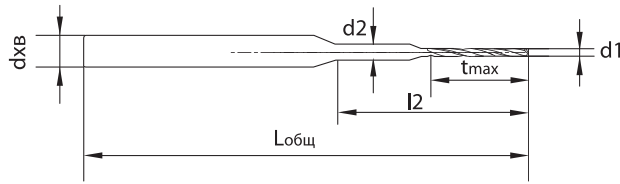

Глубина обработки		3xD	5xD				
Материал		VHM	VHM				
Покрытие		(BR)	(BR)				
Группы обрабатываемых материалов	P	•	•				
	M	•	•				
	N	•	•				
	K	•	•				
	S	•	•				
Основное применение		○	○				
H							
d1	dxв	d2	l2	Лобц	tmax	STD3610 STD3620	
2,32	3	-	-	38	12		•
2,33	3	-	-	38	12		•
2,34	3	-	-	38	12		•
2,35	3	-	-	38	7,2	•	
2,36	3	-	-	38	12		•
2,37	3	-	-	38	12		•
2,38	3	-	-	38	12		•
2,39	3	-	-	38	12		•
2,4	3	-	-	38	7,2	•	
2,41	3	-	-	38	12,5		•
2,42	3	-	-	38	12,5		•
2,43	3	-	-	38	12,5		•
2,44	3	-	-	38	12,5		•
2,45	3	-	-	38	7,5	•	
2,46	3	-	-	38	12,5		•
2,47	3	-	-	38	12,5		•
2,48	3	-	-	38	12,5		•
2,49	3	-	-	38	12,5		•
2,5	3	-	-	38	7,5	•	
2,51	3	-	-	38	12,5		•
2,52	3	-	-	38	13		•
2,53	3	-	-	38	13		•
2,54	3	-	-	38	13		•
2,55	3	-	-	38	7,8	•	
2,56	3	-	-	38	13		•
2,57	3	-	-	38	13		•

2,58	3	-	-	38	13		•
2,59	3	-	-	38	13		•
2,6	3	-	-	38	7,8	•	
		-	-	38	13		•
2,61	3	-	-	38	13,5		•
2,62	3	-	-	38	13,5		•
2,63	3	-	-	38	13,5		•
2,64	3	-	-	38	13,5		•
2,65	3	-	-	38	8,1	•	
		-	-	38	13,5		•
2,66	3	-	-	38	13,5		•
2,67	3	-	-	38	13,5		•
2,68	3	-	-	38	13,5		•
2,69	3	-	-	38	13,5		•
2,7	3	-	-	38	8,1	•	
		-	-	38	13,5		•
2,71	3	-	-	38	14		•
2,72	3	-	-	38	14		•
2,73	3	-	-	38	14		•
2,74	3	-	-	38	14		•
2,75	3	-	-	38	8,4	•	
		-	-	38	14		•
2,76	3	-	-	38	14		•
2,77	3	-	-	38	14		•
2,78	3	-	-	38	14		•
2,79	3	-	-	38	14		•
2,8	3	-	-	38	8,4	•	
		-	-	38	14		•
2,81	3	-	-	38	14,5		•
2,82	3	-	-	38	14,5		•
2,83	3	-	-	38	14,5		•
2,84	3	-	-	38	14,5		•
2,85	3	-	-	38	8,7	•	
		-	-	38	14,5		•
2,86	3	-	-	38	14,5		•
2,87	3	-	-	38	14,5		•
2,88	3	-	-	38	14,5		•
2,89	3	-	-	38	14,5		•
2,9	3	-	-	38	8,7	•	
		-	-	38	14,5		•
2,91	3	-	-	38	15		•
2,92	3	-	-	38	15		•
2,93	3	-	-	38	15		•
2,94	3	-	-	38	15		•
2,95	3	-	-	38	9	•	
		-	-	38	15		•
2,96	3	-	-	38	15		•
2,97	3	-	-	38	15		•
2,98	3	-	-	38	15		•
2,99	3	-	-	38	15		•
3	3	-	-	38	9	•	
		-	-	38	15		•

микро сверла

Система обозначений	
d1	диаметр режущей части, мм
Лобщ	общая длина, мм
l2	длина рабочей части, мм
dxв	диаметр хвостовика, мм
lxв	длина хвостовика, мм

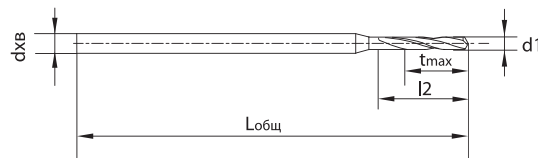

Глубина обработки		4xD	5xD	7xD	7xD			
Материал		VHM	VHM	VHM	VHM			
Покрытие		AlTiN	BR	AlTiN	TiAlN			
Группы обрабатываемых материалов Основное применение	P	•	•	•	•			
	M	•	○	•	•			
	N	○	○	○	○			
	K	•	•	•	•			
	S	○	○	○	○			
	H		○					
d1	dxв	Лобщ	l2	tmax	Артикулы			
					STD1610	STD1620	STD1630	STD2630
0,1	3	38	1,2	1,05				•
0,15			2	1,775				•
0,2	1	25	1,5	1,2		•		
0,25	3	38	2,5	2,2				•
			3	2,625				•
0,3	1	25	1,9	1,45		•		
			5	4,55				•
0,31	3	38	5	4,535				•
			2,4	1,875		•		
0,35	1	25	2,4	5,475				•
			6	5,445				•
0,37	3	38	6	5,445				•
			3	2,4		•		
0,4	1	25	3	2,4		•		
			7	6,4				•
0,45	3	38	7	6,325				•
			3,4	2,65		•		
0,5	1	25	3,4	2,65		•		
			7	6,25				•
			3	2,25	•			•
			47	3,25			•	
0,55	3	38	7	6,175				•
			3,3	2,475	•			
0,6	1	25	3,3	3,575			•	
			4,4	3,575			•	
			7	6,175				•
			3,9	3		•		
0,64	3	38	7	6,1				•
			3,6	2,7	•			
			4,8	3,9			•	
			7	6,04				•
0,65	1	25	7	6,025				•
			3,9	2,925	•			
0,7	3	38	5,2	4,225			•	
			8	6,95				•
			4,2	3,15	•			
			5,6	4,55			•	

Система обозначений	
d1	диаметр режущей части, мм
Лобщ	общая длина, мм
l2	длина рабочей части, мм
dxв	диаметр хвостовика, мм
lxв	длина хвостовика, мм

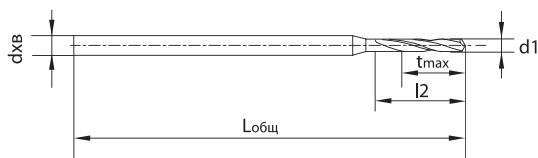

Глубина обработки		4xD	5xD	7xD	7xD			
Материал		VHM	VHM	VHM	VHM			
Покрытие		AlTiN	BR	AlTiN	TiAlN			
Группы обрабатываемых материалов Основное применение	P	•	•	•	•			
	M	•	○	•	•			
	N	○	○	○	○			
	K	•	•	•	•			
	S	○	○	○	○			
	H		○					
d1	dxв	Лобщ	l2	tmax	Артикулы			
					STD1610	STD1620	STD1630	STD2630
0,71	3	38	8	6,935				•
0,72				6,92				•
0,74				6,89				•
				6,875				•
0,75	3	47	4,5	3,375	•			
			6	4,875			•	
0,76	3	38	8	6,86				•
0,77				6,845				•
0,78				6,83				•
0,79				6,815				•
0,8	1,5	25	5,3	4,1		•		
		38	10	8,8			•	
	3	47	4,8	3,6	5,2	•		
			6,4	5,2			•	
0,81	3	38	10	8,785				•
0,82				8,77				•
0,83				8,755				•
0,84				8,74				•
0,85	3	47	5,1	3,825	•			
			6,8	5,525			•	
0,86	3	38	10	8,71				•
0,87				8,695				•
0,88				8,68				•
0,89				8,665				•
0,9	3	47	5,4	4,05	•			
			7,2	5,85			•	
0,91	3	38	10	8,635				•
0,92				8,62				•
0,93				8,605				•
0,94				8,59				•
0,95	3	47	5,7	4,275	•			
			7,6	6,175			•	

Система обозначений	
d1	диаметр режущей части, мм
Лобц	общая длина, мм
l2	длина рабочей части, мм
dxв	диаметр хвостовика, мм
lxв	длина хвостовика, мм

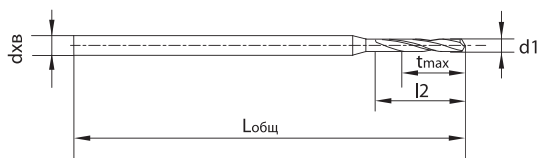

Глубина обработки		4xD	5xD	5xD	7xD	7xD	8xD			
Материал		VHM	VHM	VHM	VHM	VHM	VHM			
Покрытие		AlTiN	BR	TiAlN	AlTiN	TiAlN	TiAlN			
Группы обрабатываемых материалов Основное применение	P	•	•	•	•	•	•			
	M	•	○	•	•	•	•			
	N	○	○	○	○	○	○			
	K	•	•	•	•	•	•			
	S	○	○	○	○	○	○			
	H		○							
d1	dxв	Лобц	l2	tmax	Артикулы					
					STD1610	STD1620	STD1622	STD1630	STD2630	STD1642
0,96	3	38	10	8,56				•		
0,97				8,545				•		
0,98				8,53				•		
0,99				8,515				•		
1	1,5	25	6,8	5,3		•				
				38	10	8,5				•
	3	47	6			4,5	•			
				8	6,5		•			
1,05	3	47	6,3	4,725	•					
				8,4	6,825		•			
1,1	1,5	25	7,6	5,95		•				
				38	10	8,35				•
	47	6,6	4,95			•				
			8,8	7,15		•				
1,11	3	38	10	8,335				•		
				8,275				•		
1,15	3	47	6,9	5,175	•					
				9,2	7,475		•			
	38	10	8,2				•			
			47	7,2	5,4	•				
1,2	3	47	7,2	5,4	•					
				52	10,8	9		•		
1,21	1,5	25	8,5	6,625		•				
38				10	8,185				•	
	1,25	3	47		7,5	5,625	•			
52				11,3		9,425		•		
1,3	1,5	25	8,5	6,55		•				
				47	7,8	5,85	•			
	3	52	11,7			9,75		•		
				47	8,1	6,075	•			
1,35	3	52	12,2	10,175		•				
				38	10	7,9				•
1,4	4	52	11	8,9		•				
				3	12,6	10,5		•		
	4	52	15	12,9					•	

Система обозначений	
d1	диаметр режущей части, мм
Лобц	общая длина, мм
l2	длина рабочей части, мм
dxв	диаметр хвостовика, мм
lxв	длина хвостовика, мм

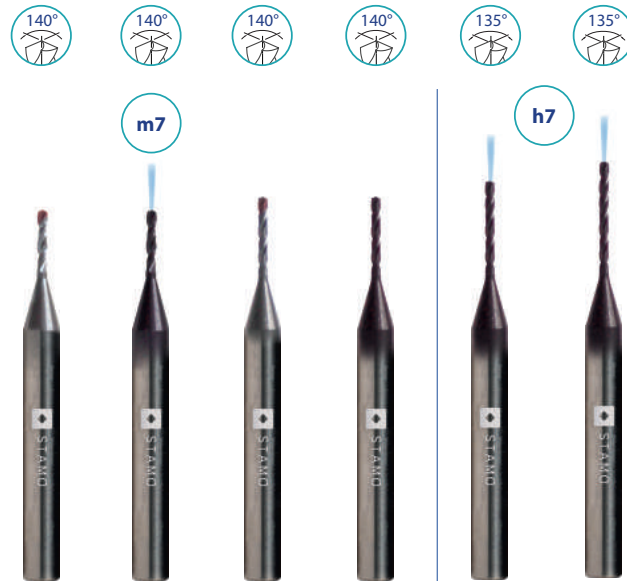
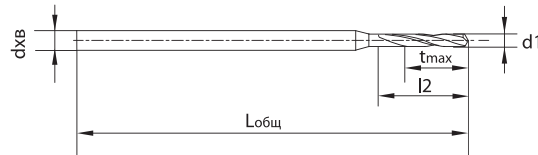

Глубина обработки		4xD	5xD	7xD	7xD	8xD	15xD			
Материал		VHM	VHM	VHM	VHM	VHM	VHM			
Покрытие		AlTiN	TiAlN	AlTiN	TiAlN	TiAlN	TiAlN			
Группы обрабатываемых материалов Основное применение	P	•	•	•	•	•	•			
	M	•	•	•	•	•	•			
	N	○	○	○	○	○	○			
	K	•	•	•	•	•	•			
	S	○	○	○	○	○	○			
	H									
d1	dxв	Лобц	l2	tmax	Артикулы					
					STD1610	STD1622	STD1630	STD2630	STD1642	STD1652
1,4	4	62	25	22,9						•
1,45	3	38	10	7,825				•		
		47	8,7	6,525	•					
1,5	4	52	12	9,825		•				
			13,1	10,925			•			
	3	38	10	7,75				•		
		47	9	6,75	•					
1,51	4	52	12	9,75		•				
			13,5	11,25						
			17	14,75						
1,52	3	38	10	7,735				•		
				7,72				•		
1,55	4	52	12	7,675				•		
				6,975	•					
	3	47	9,3	6,975	•					
1,59	4	52	12	9,675		•				
				14	11,675			•		
	3	47	9,6	7,215	•					
1,6	4	52	13	10,615		•				
				14,4	12,015			•		
	3	38	12	9,6	•					
				7,2	•					
				10,6		•				
4	52	14,4	12			•				
1,65	4	52	18	15,6				•		
				26,6					•	
	3	38	12	9,525				•		
				7,425	•					
1,7	4	56	14	11,45		•				
				12,75			•			
	3	52	15,3	12,75						

микро сверла

Система обозначений	
d1	диаметр режущей части, мм
Лобц	общая длина, мм
l2	длина рабочей части, мм
dxв	диаметр хвостовика, мм
lxв	длина хвостовика, мм

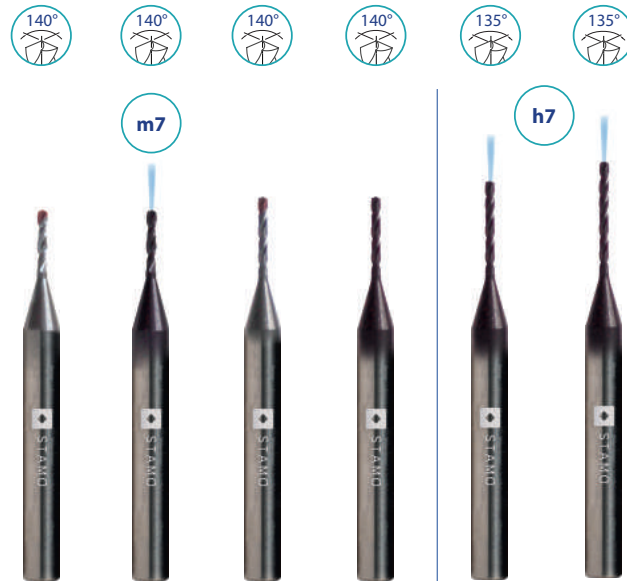
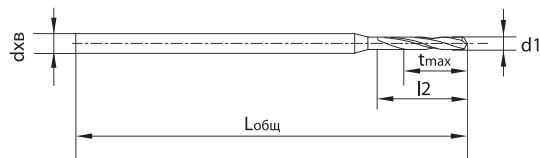

Глубина обработки		4xD	5xD	7xD	7xD	8xD	15xD			
Материал		VHM	VHM	VHM	VHM	VHM	VHM			
Покрытие		AlTiN	TiAlN	AlTiN	TiAlN	TiAlN	TiAlN			
Группы обрабатываемых материалов Основное применение	P	•	•	•	•	•	•			
	M	•	•	•	•	•	•			
	N	○	○	○	○	○	○			
	K	•	•	•	•	•	•			
	S	○	○	○	○	○	○			
	H									
d1	dxв	Лобц	l2	tmax	Артикулы					
					STD1610	STD1622	STD1630	STD2630	STD1642	STD1652
1,7	4	56	19	16,45					•	
		70	31	28,45						•
1,75	3	47	10,5	7,875	•					
		4	56	14	11,375		•			
1,8	3	52	15,8	13,175			•			
		38	12	9,3				•		
	4	52	10,8	8,1	•					
		56	14	11,3		•				
	3	52	16,2	13,5			•			
		4	56	20	17,3				•	
70	32	29,3							•	
1,81	3	38	12	9,285				•		
1,83				9,255				•		
1,85				9,225				•		
1,85	3	52	11,1	8,325	•					
		4	56	15	12,225		•			
	52	16,7	13,925			•				
1,9	3	38	12	9,15				•		
		52	11,4	8,55	•					
	4	56	15	12,15		•				
		52	17,1	14,25			•			
4	56	21	18,15					•		
	70	34	31,15						•	
1,92	3	38	12	9,12				•		
1,95				9,075				•		
1,95	4	52	11,7	8,775	•					
		56	16	13,075		•				
	3	52	17,6	14,675			•			
1,98	3	38	12	9,03				•		
		59		9,03	•					
	4	56	16	13,03		•				
		63	18	15,03			•			
2	3	38	12	9				•		
		59		9	•					
	4	56	16	13					•	

Система обозначений	
d1	диаметр режущей части, мм
Лобц	общая длина, мм
l2	длина рабочей части, мм
dxв	диаметр хвостовика, мм
lxв	длина хвостовика, мм

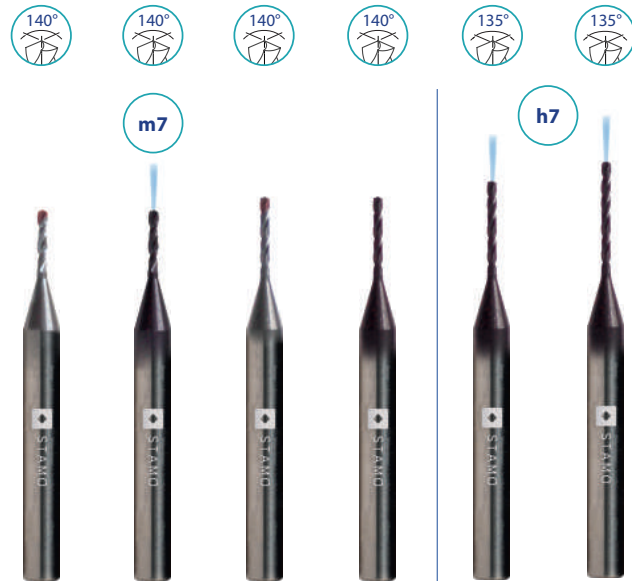
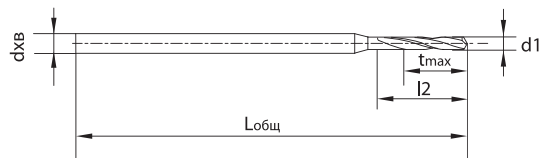

Глубина обработки		4xD	5xD	7xD	7xD	8xD	15xD			
Материал		VHM	VHM	VHM	VHM	VHM	VHM			
Покрытие		AlTiN	TiAlN	AlTiN	TiAlN	TiAlN	TiAlN			
Группы обрабатываемых материалов Основное применение	P	•	•	•	•	•	•			
	M	•	•	•	•	•	•			
	N	○	○	○	○	○	○			
	K	•	•	•	•	•	•			
	S	○	○	○	○	○	○			
	H									
d1	dxв	Лобц	l2	tmax	Артикулы					
					STD1610	STD1622	STD1630	STD2630	STD1642	STD1652
2	4	63	18	15			•		•	
		56	22	19						•
		70	36	33						
2,05	3	38	12	8,925				•		
		59	12,3	9,225	•					
		4	56	16	12,925		•			
2,1	3	63	18,5	15,425			•			
		38	12	8,85				•		
		59	12,6	9,45	•					
		62	17	13,85		•				
		63	18,9	15,75			•			
		62	23	19,85					•	
		78	38	34,85						•
2,15	3	59	12,9	9,675	•					
		62	17	13,775		•				
		63	19,4	16,175			•			
2,2	3	59	13,2	9,9	•					
		62	18	14,7		•				
		63	19,8	16,5			•			
		62	24	20,7						•
2,25	4	78	40	36,7						•
		59	13,5	10,125	•					
		62	18	14,625		•				
		63	20,3	16,925			•			
2,3	4	59	13,8	10,35	•					
		62	18	14,55		•				
		63	20,7	17,25			•			
		62	25	21,55					•	
2,35	4	78	42	38,55						•
		59	14,1	10,575	•					
		62	19	15,475		•				
2,38	4	63	21,2	17,675			•			
		59	14,4	10,83	•					
		62	19	15,43		•				
		63	21,6	18,03			•			

микро сверла

Система обозначений	
d1	диаметр режущей части, мм
Лобщ	общая длина, мм
l2	длина рабочей части, мм
dxв	диаметр хвостовика, мм
lxв	длина хвостовика, мм

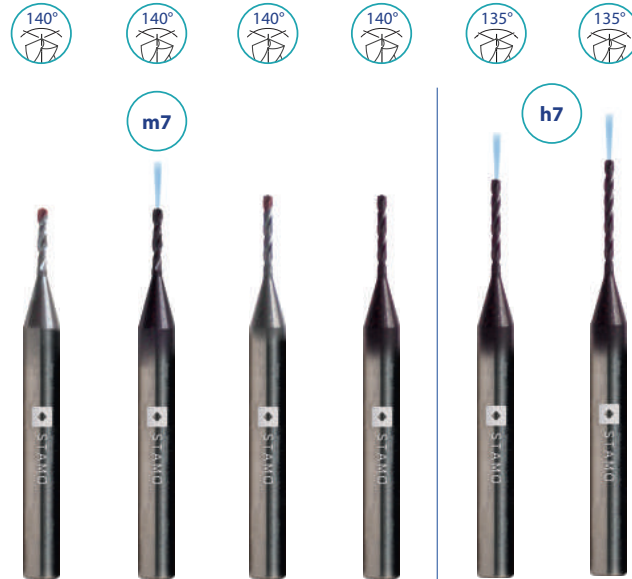
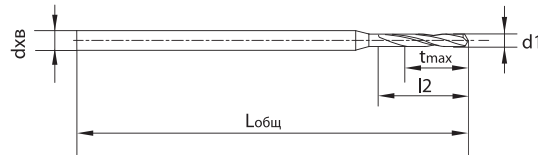

Глубина обработки		4xD	5xD	7xD	7xD	8xD	15xD			
Материал		VHM	VHM	VHM	VHM	VHM	VHM			
Покрытие		AlTiN	TiAlN	AlTiN	TiAlN	TiAlN	TiAlN			
Группы обрабатываемых материалов Основное применение	P	•	•	•	•	•	•			
	M	•	•	•	•	•	•			
	N	○	○	○	○	○	○			
	K	•	•	•	•	•	•			
	S	○	○	○	○	○	○			
H										
d1	dxв	Лобщ	l2	tmax	Артикулы					
					STD1610	STD1622	STD1630	STD2630	STD1642	STD1652
2,4	3	38	12	8,4				•		
		59	14,4	10,8	•					
	4	62	19	15,4		•				
		63	21,6	18			•			
2,45	4	62	26	22,4					•	
		78	44	40,4						•
		59	14,7	11,025	•					
2,5	3	62	20	16,325		•				
		63	22,1	18,425			•			
	4	38	12	8,25				•		
		59	15	11,25	•					
2,55	4	62	20	16,25		•				
		63	22,5	18,75			•			
		62	28	24,25					•	
		78	45	41,25						•
		59	15,3	11,475	•					
2,6	4	62	20	16,175		•				
		63	23	19,175			•			
		38	12	8,1				•		
		59	15,6	11,7	•					
		66	21	17,1		•				
		67	23,4	19,5			•			
2,65	4	66	29	25,1					•	
		87	47	43,1						•
		59	15,9	11,925	•					
		66	21	17,025		•				
		67	23,9	19,925			•			
2,7	4	59	16,2	12,15	•					
		66	22	17,95		•				
		67	24,3	20,25			•			
		66	30	25,95				•		
		87	48	43,95					•	

Система обозначений	
d1	диаметр режущей части, мм
Лобц	общая длина, мм
l2	длина рабочей части, мм
dxв	диаметр хвостовика, мм
lxв	длина хвостовика, мм

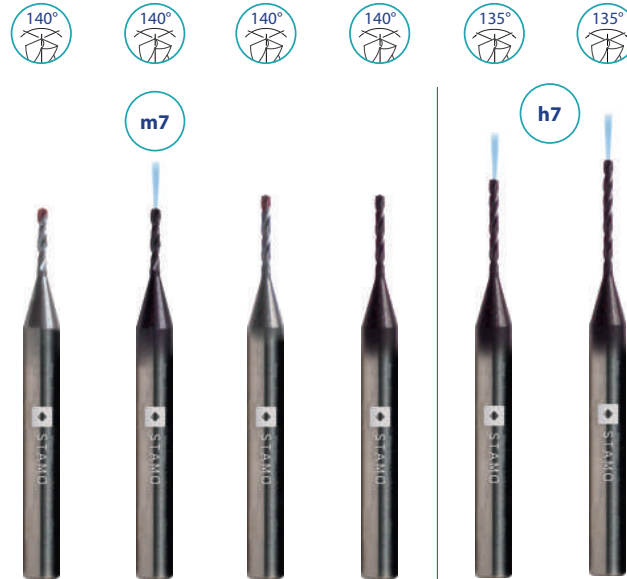
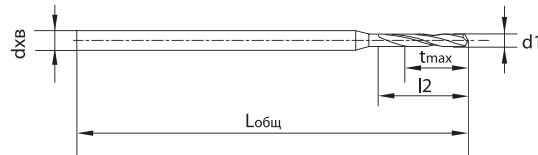

Глубина обработки		4xD	5xD	7xD	7xD	8xD	15xD			
Материал		VHM	VHM	VHM	VHM	VHM	VHM			
Покрытие		AlTiN	TiAlN	AlTiN	TiAlN	TiAlN	TiAlN			
Группы обрабатываемых материалов Основное применение	P	•	•	•	•	•	•			
	M	•	•	•	•	•	•			
	N	○	○	○	○	○	○			
	K	•	•	•	•	•	•			
	S	○	○	○	○	○	○			
	H									
d1	dxв	Лобц	l2	tmax	Артикулы					
					STD1610	STD1622	STD1630	STD2630	STD1642	STD1652
2,75	3	38	12	7,875				•		
		59	16,5	12,375	•					
		66	22	17,875		•				
2,78	3	67	24,8	20,675			•			
		59	16,8	12,63	•					
		66	22	17,83		•				
2,8	3	67	25,2	21,03			•			
		59	16,8	12,6	•					
		66	22	17,8		•				
2,8	4	67	25,2	21			•			
		66	31	26,8					•	
		87	50	45,8						•
		59	17,1	12,825	•					
		66	23	18,725		•				
		67	25,7	21,425			•			
2,85	4	59	17,4	13,05	•					
		66	23	18,65		•				
		67	26,1	21,75			•			
		66	32	27,65				•		
2,9	4	87	52	47,65						•
		59	17,4	13,05	•					
		66	23	18,65		•				
		67	26,1	21,75			•			
2,95	3	38	12	7,575				•		
		59	17,7	13,275	•					
		66	24	19,575		•				
3	4	67	26,6	22,175			•			
		38	12	7,5				•		
		59	18	13,5	•					
		66	24	19,5		•				
		67	27	22,5			•			
3	4	66	33	28,5					•	
		87	54	49,5						•

микро сверла

СВЕРЛА ПУШЕЧНЫЕ

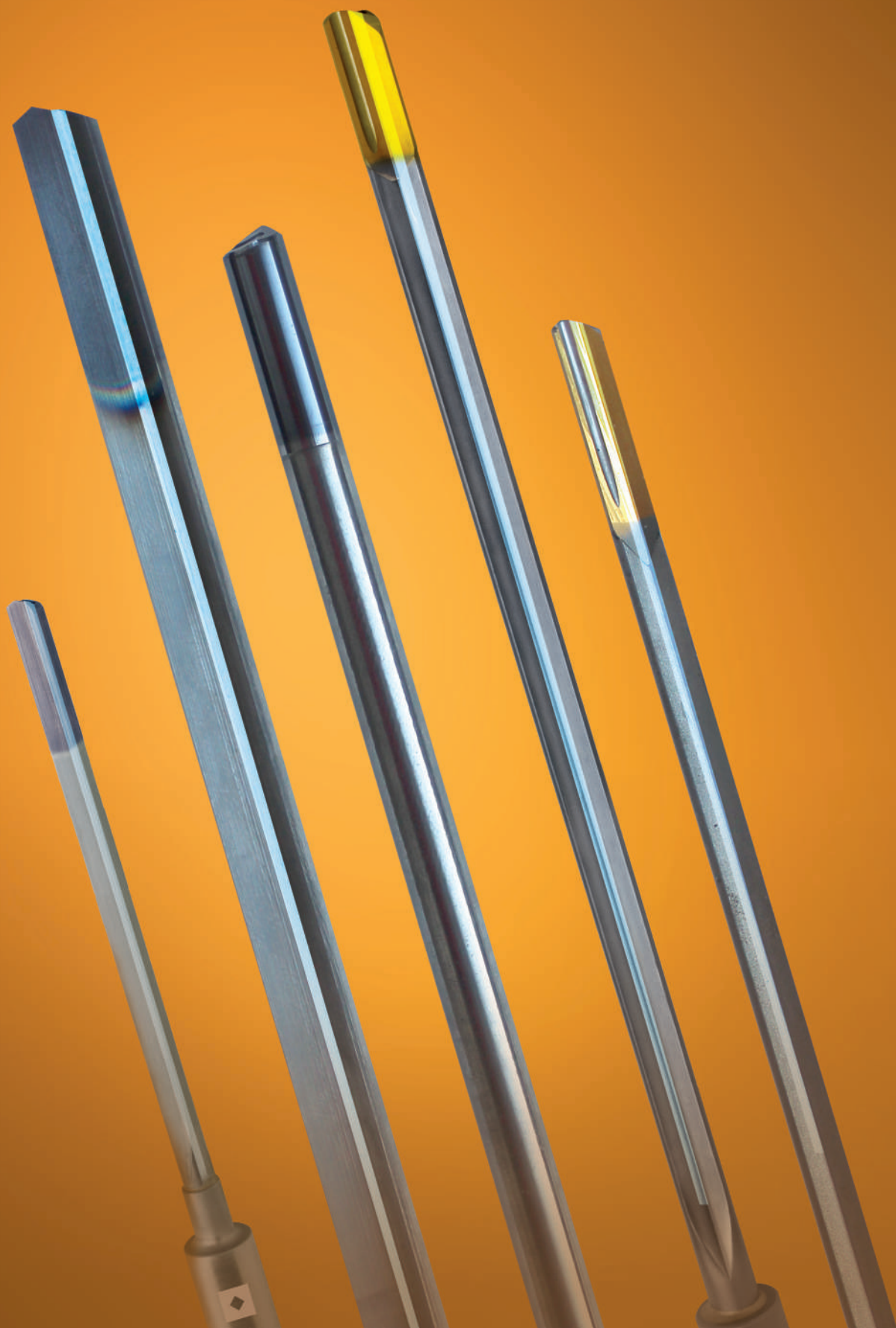

СВЕРЛА ПУШЕЧНЫЕ

ОДНОЛЕЗВИЙНЫЕ ТВЕРДОСПЛАВНЫЕ

универсальное применение

Система обозначений	
d1	диаметр режущей части, мм
Лобц	общая длина, мм
l2	длина рабочей части, мм
dxв	диаметр хвостовика, мм
lxв	длина хвостовика, мм

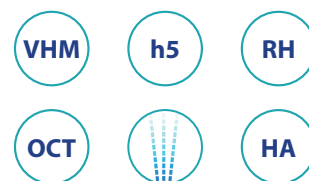
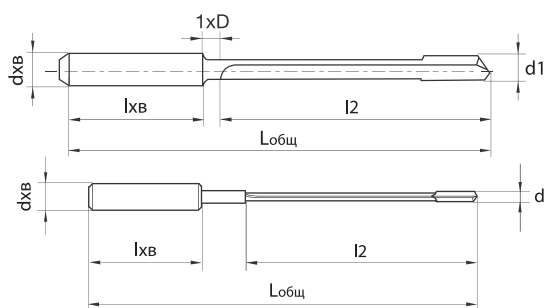

Глубина обработки		25xD	50xD	75xD	L=45	L=45	L=80	L=80	L=120	L=120	L=160	L=160	
Материал		VHM	VHM	VHM	VHM	VHM	VHM	VHM	VHM	VHM	VHM	VHM	
Покрытие		AITIN	AITIN	AITIN	BR	AITIN	BR	AITIN	BR	AITIN	BR	AITIN	
Группы обрабатываемых материалов Основное применение	P	•	•	•	○	•	○	•	○	•	○	•	
	M	•	•	•	○	○	○	○	○	○	○	○	
	N	•	•	•	•	○	•	○	•	○	•	○	
	K	○	○	○	○	•	○	•	○	•	○	•	
	S	○	○	○	•	○	•	○	•	○	•	○	
		H	○	○	○	○	○	○	○	○	○	○	
d1	dxв	Лобц	l2	lxв	Артикулы								
						STD	STD	STD	STD	STD	STD	STD	
						1795200	1795210	1795211	1795012	1795100	1795001	1795101	1795013
						1795111	1795011	1795112					
1	3	65	32	28	•								
		90	57		•								
		115	82			•							
1,191	3	70	39	28	•								
		100	68			•							
		130	98				•						
1,2	4	90	45	28		•	•						
		125	80				•	•					
		80	49			•							
1,5	4	90	45	28			•	•					
		120	86				•	•					
		125	80					•	•				
		155	124										
		165	120							•	•		
1,588	4	205	160	28							•	•	
		85	51			•							
		125	91				•						
1,59	4	165	131	28									
		90	45				•	•					
		125	80					•	•				
		165	120							•	•		
1,6	4	205	160	28									
		90	45				•	•					
		125	80					•	•				
		165	120							•	•		
1,98	4	205	160	28									
		90	45				•	•					
		125	80					•	•				
		165	120							•	•		
1,984	4	205	160	28									
		95	64			•							
		145	114				•						
		195	163										

пушечные сверла

СВЕРЛА ПУШЕЧНЫЕ

ОДНОЛЕЗВИЙНЫЕ ТВЕРДОСПЛАВНЫЕ

универсальное применение

Система обозначений	
d1	диаметр режущей части, мм
Лобц	общая длина, мм
l2	длина рабочей части, мм
dxв	диаметр хвостовика, мм
lхв	длина хвостовика, мм

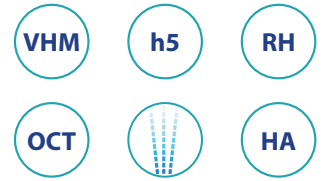
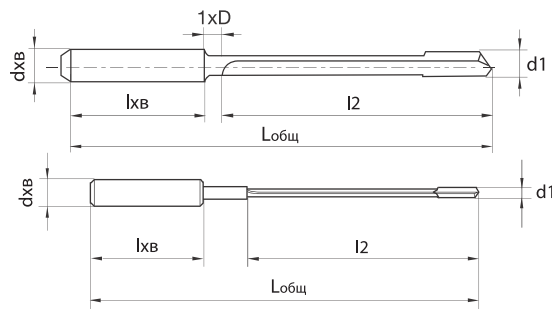

Глубина обработки	25xD	50xD	75xD	L=45	L=45	L=80	L=80	L=120	L=120	L=160	L=160				
Материал	VHM	VHM	VHM	VHM	VHM	VHM	VHM	VHM	VHM	VHM	VHM				
Покрытие	AITIN	AITIN	AITIN	BR	AITIN	BR	AITIN	BR	AITIN	BR	AITIN				
Группы обрабатываемых материалов Основное применение	P	•	•	•	○	•	○	•	○	•	○				
	M	•	•	•	○	○	○	○	○	○	○				
	N	•	•	•	•	○	•	○	•	○	○				
	K	○	○	○	○	•	○	•	○	•	○				
	S	○	○	○	•	○	•	○	•	○	•				
	H	○	○	○	○	○	○	○	○	○	○				
d1	dxв	Лобц	l2	lхв	Артикулы										
					STD 1795200	STD 1795210	STD 1795211	STD 1795012	STD 1795100	STD 1795001	STD 1795101	STD 1795013	STD 1795111	STD 1795011	STD 1795112
2	4	90	45	28	•			•	•						
		95	65		•										
		125	80					•	•						
		145	115			•									
		165	120								•	•			
		195	165												
205	160										•	•			
2,381	4	100	70	28	•										
		160	130		•										
		220	190				•								
2,5	10	100	45	40				•	•						
	4	115	85	28	•										
	10	135	80	40					•	•					
	10	175	120								•	•			
	4	185	155	28		•									
	10	215	160	40									•	•	
4	255	220	28												
2,7	10	100	45	40				•	•						
		135	80						•	•					
		175	120								•	•			
		215	160										•	•	
2,778	4	115	85	28	•										
		185	155			•									
		255	220				•								
3	10	100	45	40				•	•						
	6	145	105	36	•										
	10	175	120	40						•	•				
	10	215	160									•	•		
	6	230	190	36		•									
	6	290	247				•								
6	145	105			•										
3,175	6	230	190			•									
		320	280				•								

пушечные
сверла

СВЕРЛА ПУШЕЧНЫЕ

ОДНОЛЕЗВИЙНЫЕ ТВЕРДОСПЛАВНЫЕ



универсальное применение

Система обозначений	
d1	диаметр режущей части, мм
Лобц	общая длина, мм
l2	длина рабочей части, мм
dxв	диаметр хвостовика, мм
lхв	длина хвостовика, мм

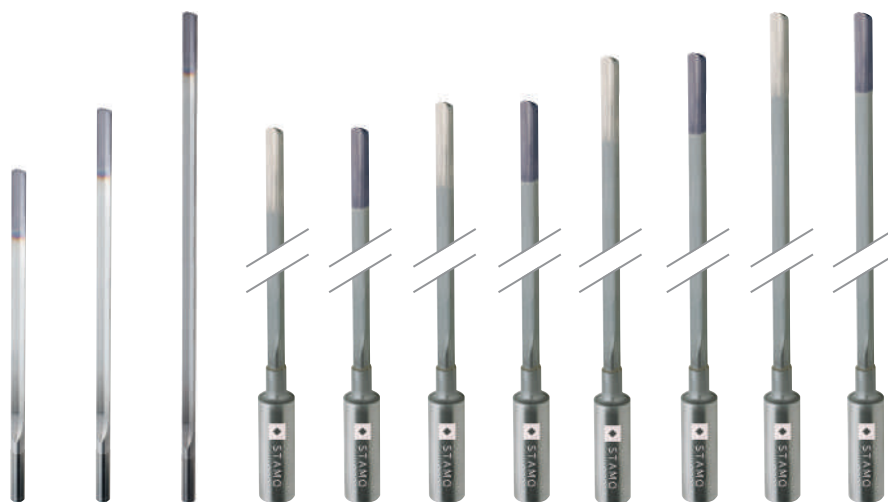
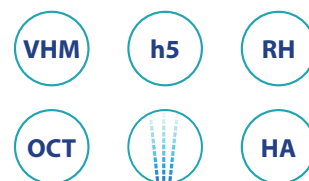
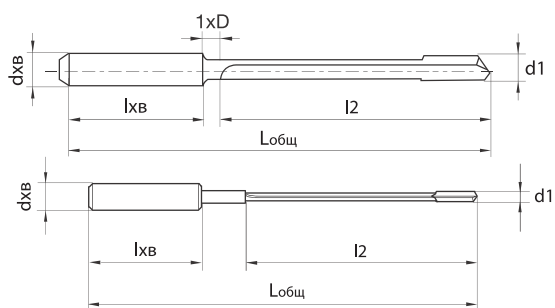

Глубина обработки	25xD	50xD	75xD	L=45	L=45	L=80	L=80	L=120	L=120	L=160	L=160				
Материал	VHM	VHM	VHM	VHM	VHM	VHM	VHM	VHM	VHM	VHM	VHM				
Покрытие	AITIN	AITIN	AITIN	BR	AITIN	BR	AITIN	BR	AITIN	BR	AITIN				
Группы обрабатываемых материалов Основное применение	P	•	•	•	○	•	○	•	○	•	○				
	M	•	•	•	○	○	○	○	○	○	○				
	N	•	•	•	•	○	•	○	•	○	○				
	K	○	○	○	○	•	○	•	○	•	○				
	S	○	○	○	•	○	•	○	•	○	•				
	H	○	○	○	○	○	○	○	○	○	○				
d1	dxв	Лобц	l2	lхв	Артикулы										
					STD	STD	STD	STD	STD	STD	STD				
					1795200	1795210	1795211	1795012	1795100	1795001	1795101	1795013	1795111	1795011	1795112
3,2	10	100	45	40	•	•									
		135	80				•	•							
		175	120							•	•				
3,5	10	135	80	40											
	6	145	105		36	•									
	10	175	120		40						•	•			
3,572	6	215	160	36											
		230	190			•									
		320	280				•								
		160	120			•									
3,969	6	260	220	36		•									
		360	320				•								
		160	120			•									
4	10	260	220	36		•									
		360	320				•								
	6	175	120	40						•	•				
		215	160	40								•	•		
4,2	10	260	220	36		•									
		360	320				•								
		135	80					•	•						
4,366	6	175	120	36							•	•			
		215	160										•	•	
		220	180			•									
4,5	10	290	245	36		•									
		395	355				•								
		135	80						•	•					
4,5	10	175	120	40								•	•		
		215	160										•	•	

пушечные сверла

СВЕРЛА ПУШЕЧНЫЕ

ОДНОЛЕЗВИЙНЫЕ ТВЕРДОСПЛАВНЫЕ

универсальное применение

Система обозначений	
d1	диаметр режущей части, мм
Лобц	общая длина, мм
l2	длина рабочей части, мм
dxв	диаметр хвостовика, мм
lхв	длина хвостовика, мм

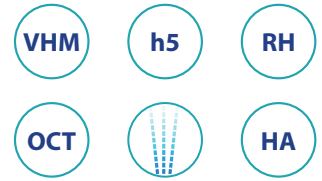
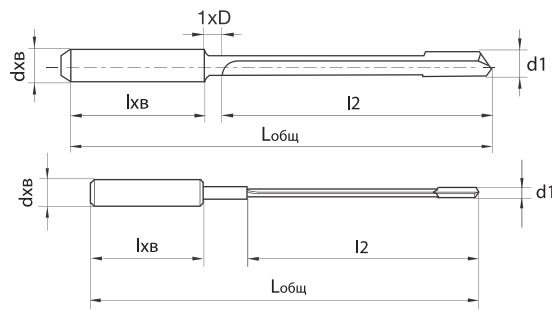

Глубина обработки	25xD	50xD	75xD	L=80	L=80	L=120	L=120	L=160	L=160					
Материал	VHM	VHM	VHM	VHM	VHM	VHM	VHM	VHM	VHM					
Покрытие	AlTiN	AlTiN	AlTiN	BR	AlTiN	BR	AlTiN	BR	AlTiN					
Группы обрабатываемых материалов Основное применение	P	•	•	•	○	•	○	•	○					
	M	•	•	•	○	○	○	○	○					
	N	•	•	•	•	○	•	○	○					
	K	○	○	○	○	•	○	•	○					
	S	○	○	○	•	○	•	○	•					
	H	○	○	○	○	○	○	○	○					
d1	dxв	Лобц	l2	lхв	Артикулы									
					STD 1795200	STD 1795210	STD 1795211	STD 1795001	STD 1795101	STD 1795013	STD 1795111	STD 1795011	STD 1795112	
4,763	6	220	180	36	•									
		310	268			•								
		430	387				•							
5	10	135	80	40				•	•					
		175	120						•	•				
		215	160								•	•		
	5,159	6	220	180	36	•								
			370	330			•							
450			406				•							
220			180			•								
370			330				•							
5,556	6	465	419	36			•							
		220	180			•								
		370	330				•							
5,953	6	525	485	36			•							
		220	180			•								
		370	330				•							
6	6	525	485	36			•							
		220	180			•								
		370	330				•							
6,35	8	220	180	36			•							
		525	485				•							
		260	210			•								
6,5	8	430	385	36			•							
		560	516				•							
		260	210			•								
6,747	8	430	385	36			•							
		575	528				•							
		260	210			•								
6,747	8	430	385	36			•							
		595	548				•							

пушечные
сверла

СВЕРЛА ПУШЕЧНЫЕ

ОДНОЛЕЗВИЙНЫЕ ТВЕРДОСПЛАВНЫЕ



STAMO

универсальное применение

Система обозначений	
d1	диаметр режущей части, мм
Лобщ	общая длина, мм
l2	длина рабочей части, мм
dxв	диаметр хвостовика, мм
lxв	длина хвостовика, мм

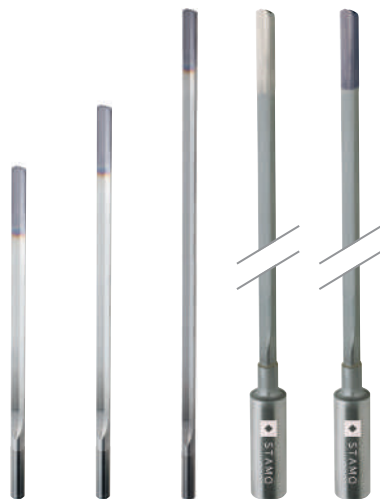
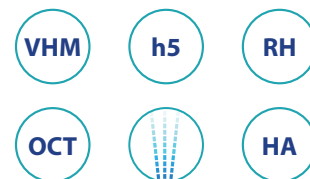
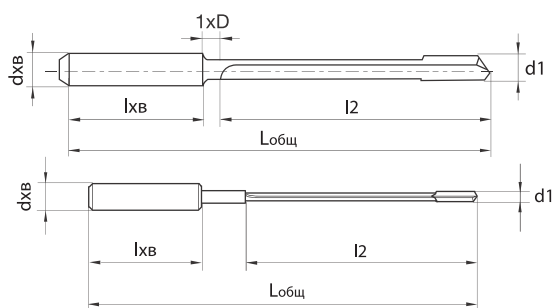

Глубина обработки		25xD	50xD	75xD	L=160	L=160			
Материал		VHM	VHM	VHM	VHM	VHM			
Покрытие		ALTiN	ALTiN	ALTiN	BR	ALTiN			
Группы обрабатываемых материалов Основное применение	P	•	•	•	○	•			
	M	•	•	•	○	○			
	N	•	•	•	•	○			
	K	○	○	○	○	•			
	S	○	○	○	•	○			
	H	○	○	○	○	○			
d1	dxв	Лобщ	l2	lxв	Артикулы				
					STD 1795200	STD 1795210	STD 1795211	STD 1795011	STD 1795112
7	8	260	210	36	•				
		430	385			•			
		615	568				•		
285		240	•						
485		440			•				
625		580				•			
7,144	8	285	240	•					
		485	440		•				
7,541	8	285	240	•					
		485	440		•				
7,938	8	285	240	•					
		485	440		•				
8	16	225	160	48			•	•	
	8	285	240	•					
		485	440		•				
9	10	350	300	40	•				
		555	506		•				
		350	300	•					
10	10	615	562		•				
		420	360	•					
11,113	12	420	360	•					
		420	360	•					
12,7	14	455	396	•					
		500	437	•					
15	16	535	468	•					
		560	495	•					
15,875	16	565	499	•					
16		565	499	•					

пушечные сверла

СВЕРЛА ПУШЕЧНЫЕ

ОДНОЛЕЗВИЙНЫЕ С НАПАЙНОЙ ТВЕРДОСПЛАВНОЙ ГОЛОВКОЙ

универсальное применение

Система обозначений	
d1	диаметр режущей части, мм
Лобц	общая длина, мм
l2	длина рабочей части, мм
dxв	диаметр хвостовика, мм
lхв	длина хвостовика, мм

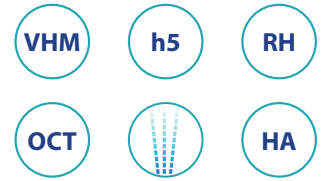
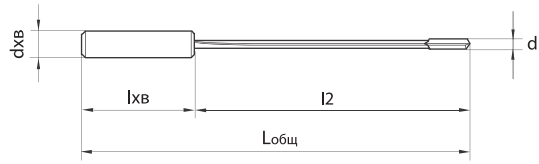

Глубина обработки					20xD	20xD	30xD	30xD	40xD	40xD	80xD	80xD
Материал					VHM	VHM	VHM	VHM	VHM	VHM	VHM	VHM
Покрытие					TIN	TiCN	TIN	TiCN	TIN	TiCN	TIN	TiCN
Группы обрабатываемых материалов Основное применение	P				•	○	•	○	•	○	•	○
	M				○	•	○	•	○	•	○	•
	N				○	○	○	○	○	○	○	○
	K				•	○	•	○	•	○	•	○
	S				○	•	○	•	○	•	○	•
	H				○	○	○	○	○	○	○	○
d1	dxв	Лобц	l2	lхв	Артикулы							
					STD 1795014	STD 1795013	STD 1795018	STD 1795114	STD 1795015	STD 1795115	STD 1795016	STD 1795116
3,97	10	150	100	40	•	•						
		200	155			•						
		230	185					•	•			
4	12	150	100	45	•	•						
		200	155			•	•					
		230	185					•	•			
4,2	12	160	110	45	•	•						
		210	165					•	•			
		240	195							•	•	
4,5	12	170	120	45	•	•						
		220	175					•	•			
		250	205							•	•	
4,95	16	480	432	48							•	•
		180	130			•	•					
		230	182					•	•			
5	16	280	232	48								
		480	432								•	•
		180	130			•	•					
5,106	16	230	182	48								
		280	232					•	•			
		190	140			•	•					
5,5	16	245	197	48								
		300	252					•	•			
		560	512								•	•
5,95	16	210	160	48	•	•						
		260	212					•	•			
		320	272							•	•	
6	16	590	542	48							•	•
		220	170			•	•					
		275	227					•	•			
6,35	16	340	292	48								
										•	•	

пушечные
сверла

СВЕРЛА ПУШЕЧНЫЕ



STAMO

ОДНОЛЕЗВИЙНЫЕ С НАПАЙНОЙ ТВЕРДОСПЛАВНОЙ ГОЛОВКОЙ

универсальное применение

Система обозначений	
d1	диаметр режущей части, мм
Лобц	общая длина, мм
l2	длина рабочей части, мм
dxв	диаметр хвостовика, мм
lхв	длина хвостовика, мм

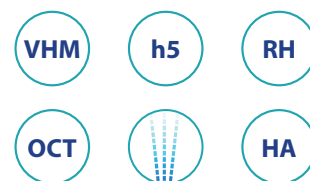
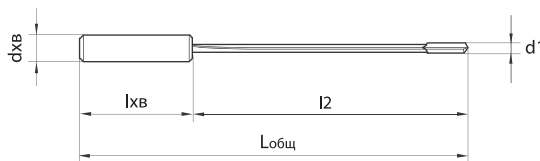

Глубина обработки					20xD	20xD	30xD	30xD	40xD	40xD	80xD	80xD	
Материал					VHM	VHM	VHM	VHM	VHM	VHM	VHM	VHM	
Покрытие					TIN	TiCN	TIN	TiCN	TIN	TiCN	TIN	TiCN	
Группы обрабатываемых материалов Основное применение					P	•	○	•	○	•	○	•	○
					M	○	•	○	•	○	•	○	•
					N	○	○	○	○	○	○	○	○
					K	•	○	•	○	•	○	•	○
					S	○	•	○	•	○	•	○	•
					H	○	○	○	○	○	○	○	○
d1	dxв	Лобц	l2	lхв	Артикулы								
					STD	STD	STD	STD	STD	STD	STD	STD	
					1795014	1795013	1795018	1795114	1795015	1795115	1795016	1795116	
6,5	16	220	170	48	•	•							
		275	227			•							
		340	292				•	•					
6,95	16	650	602	48						•	•		
		235	185		•	•							
7	16	290	242	48			•	•					
		370	322					•	•				
		7,888	16		740	692						•	•
7,938	16	260	210	48	•	•							
		320	272				•	•					
		420	372						•	•			
7,95	16	740	692	48						•	•		
		260	210		•	•							
8	16	320	272	48			•	•					
		420	372					•	•				
		8,95	16		820	772						•	•
9	16	280	230	48	•	•							
		350	302				•	•					
		450	402						•	•			
9,475	16	870	822	48						•	•		
		290	240		•	•							
9,525	16	380	330	48			•	•					
		480	432						•	•			
		9,95	20		910	860						•	•
10	20	320	260	50	•	•							
		400	350										
		510	460				•	•					
		10,95	995		945						•	•	

пушечные сверла

СВЕРЛА ПУШЕЧНЫЕ



STAMO

ОДНОЛЕЗВИЙНЫЕ С НАПАЙНОЙ ТВЕРДОСПЛАВНОЙ ГОЛОВКОЙ

универсальное применение

Система обозначений	
d1	диаметр режущей части, мм
Лобц	общая длина, мм
l2	длина рабочей части, мм
dxв	диаметр хвостовика, мм
lхв	длина хвостовика, мм

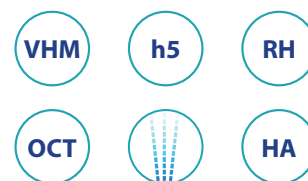
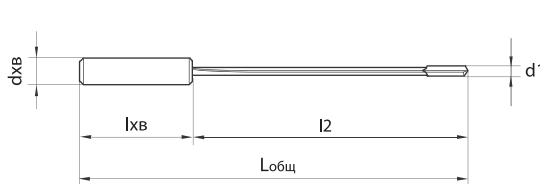

Глубина обработки		20xD	20xD	30xD	30xD	40xD	40xD	80xD	80xD		
Материал		VHM	VHM	VHM	VHM	VHM	VHM	VHM	VHM		
Покрытие		TIN	TiCN	TIN	TiCN	TIN	TiCN	TIN	TiCN		
Группы обрабатываемых материалов Основное применение	P	•	○	•	○	•	○	•	○		
	M	○	•	○	•	○	•	○	•		
	N	○	○	○	○	○	○	○	○		
	K	•	○	•	○	•	○	•	○		
	S	○	•	○	•	○	•	○	•		
	H	○	○	○	○	○	○	○	○		
d1	dxв	Лобц	l2	lхв	Артикулы						
					STD	STD	STD	STD	STD		
					1795014	1795013	1795018	1795114	1795015		
					1795115	1795016	1795116				
11	20	340	290	50	•	•					
		430	380				•	•			
		550	500						•	•	
11,063	20	995	945							•	•
		340	290		•	•					
		430	380				•	•			
11,113	20	550	500						•	•	
		1080	1030							•	•
		370	310		•	•					
12	20	450	400				•	•			
		600	550					•	•		
		1140	1090						•	•	
12,65	20	385	330	•	•						
		500	450			•	•				
		635	585					•	•		

пушечные сверла

СВЕРЛА ПУШЕЧНЫЕ



STAMO

СВЕРХДЛИННЫЕ, ОДНОЛЕЗВИЙНЫЕ С НАПАЙНОЙ ТВЕРДОСПЛАВНОЙ ГОЛОВКОЙ

универсальное применение

Система обозначений	
d1	диаметр режущей части, мм
Лобц	общая длина, мм
l2	длина рабочей части, мм
dxв	Диаметр хвостовика, мм
lхв	длина хвостовика, мм

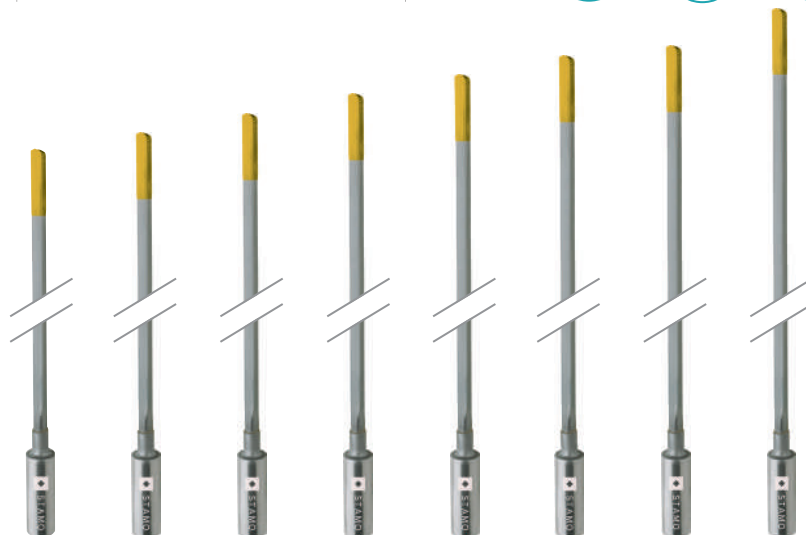
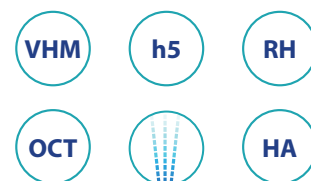
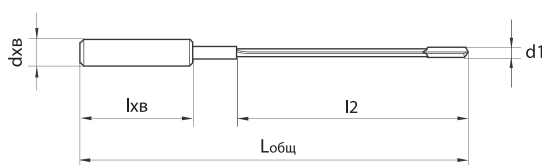

Глубина обработки					l=600	l=800	l=1000	l=1200	l=1400	l=1600	l=1800	l=2000
Материал					VHM	VHM	VHM	VHM	VHM	VHM	VHM	VHM
Покрытие					TIN	TIN	TIN	TIN	TIN	TIN	TIN	TIN
Группы обрабатываемых материалов Основное применение	P				•	•	•	•	•	•	•	•
	M				○	○	○	○	○	○	○	○
	N				○	○	○	○	○	○	○	○
	K				•	•	•	•	•	•	•	•
	S				○	○	○	○	○	○	○	○
H				○	○	○	○	○	○	○	○	
d1	dxв	Лобц	l2	lхв	Артикулы							
					STD	STD	STD	STD	STD	STD	STD	STD
					1795318	1795400	1795413	1795401	1795414	1795411	1795415	1795412
3	25	600	500	70	•							
		800	700			•						
		1000	900				•					
		1200	1100					•				
4	25	600	500	70	•							
		800	700			•						
		1000	900				•					
		1200	1100					•				
		1400	1300						•			
		1600	1500							•		
		1800	1700								•	
2000	1900								•			
5	25	600	500	70	•							
		800	700			•						
		1000	900				•					
		1200	1100					•				
		1400	1300						•			
		1600	1500							•		
1800	1700							•				
2000	1900								•			
5,5		1600	1500						•			
6	25	600	500	70	•							
		800	700			•						
		1000	900				•					
		1200	1100					•				
		1400	1300						•			
		1600	1500							•		
		1800	1700								•	
2000	1900								•			

пушечные сверла

СВЕРЛА ПУШЕЧНЫЕ

СВЕРХДЛИННЫЕ, ОДНОЛЕЗВИЙНЫЕ С НАПАЙНОЙ ТВЕРДОСПЛАВНОЙ ГОЛОВКОЙ

универсальное применение

Система обозначений	
d1	диаметр режущей части, мм
Лобц	общая длина, мм
l2	длина рабочей части, мм
dxв	Диаметр хвостовика, мм
lxв	длина хвостовика, мм

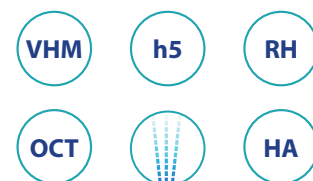
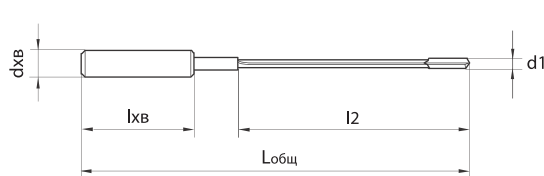

Глубина обработки		l=600	l=800	l=1000	l=1200	l=1400	l=1600	l=1800	l=2000			
Материал		VHM	VHM	VHM	VHM	VHM	VHM	VHM	VHM			
Покрытие		TIN	TIN	TIN	TIN	TIN	TIN	TIN	TIN			
Группы обрабатываемых материалов Основное применение	P	•	•	•	•	•	•	•	•			
	M	○	○	○	○	○	○	○	○			
	N	○	○	○	○	○	○	○	○			
	K	•	•	•	•	•	•	•	•			
	S	○	○	○	○	○	○	○	○			
	H	○	○	○	○	○	○	○	○			
d1	dxв	Лобц	l2	lxв	Артикулы							
					STD 1795318	STD 1795400	STD 1795413	STD 1795401	STD 1795414	STD 1795411	STD 1795415	STD 1795412
7	25	600	500	70	•							
		800	700		•							
		1000	900			•						
		1200	1100				•					
		1400	1300					•				
		1600	1500						•			
		1800	1700							•		
2000	1900							•				
7,5		1600	1500					•				
8	25	600	500	70	•							
		800	700			•						
		1000	900				•					
		1200	1100					•				
		1400	1300						•			
		1600	1500							•		
		1800	1700								•	
2000	1900								•			
9	25	600	500	70	•							
		800	700			•						
		1000	900				•					
		1200	1100					•				
		1400	1300						•			
		1600	1500							•		
		1800	1700								•	
2000	1900								•			
9,5		1600	1500					•				
10	25	600	500	70	•							
		800	700			•						
		1000	900				•					
		1200	1100					•				
		1400	1300						•			
		1600	1500							•		
		1800	1700								•	
2000	1900								•			

пушечные сверла

СВЕРЛА ПУШЕЧНЫЕ



STAMO

СВЕРХДЛИННЫЕ, ОДНОЛЕЗВИЙНЫЕ С НАПАЙНОЙ ТВЕРДОСПЛАВНОЙ ГОЛОВКОЙ

универсальное применение

Система обозначений	
d1	диаметр режущей части, мм
Лобц	общая длина, мм
l2	длина рабочей части, мм
dxв	Диаметр хвостовика, мм
lхв	длина хвостовика, мм

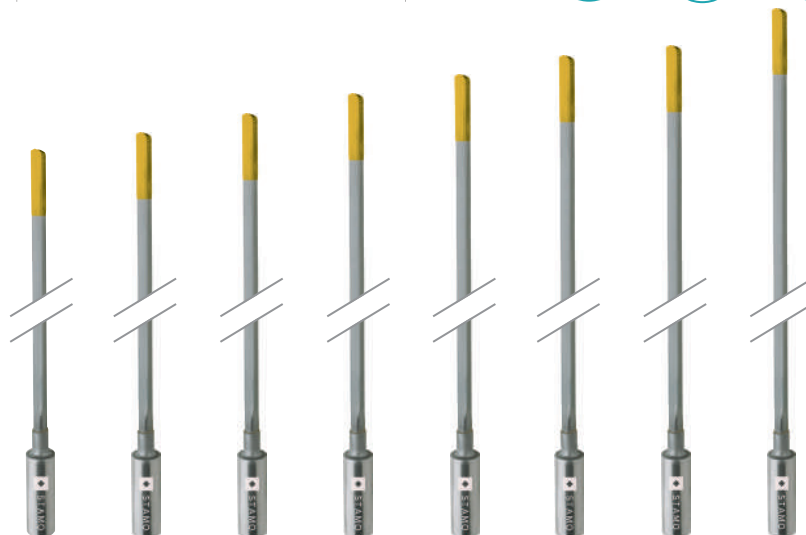
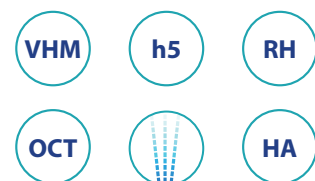
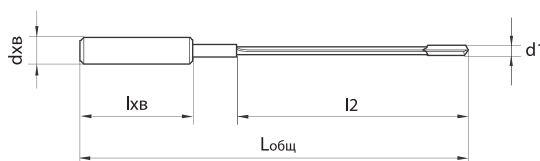

Глубина обработки		l=600	l=800	l=1000	l=1200	l=1400	l=1600	l=1800	l=2000			
Материал		VHM	VHM	VHM	VHM	VHM	VHM	VHM	VHM			
Покрытие		TIN	TIN	TIN	TIN	TIN	TIN	TIN	TIN			
Группы обрабатываемых материалов Основное применение	P	•	•	•	•	•	•	•	•			
	M	○	○	○	○	○	○	○	○			
	N	○	○	○	○	○	○	○	○			
	K	•	•	•	•	•	•	•	•			
	S	○	○	○	○	○	○	○	○			
H	○	○	○	○	○	○	○	○	○			
d1	dxв	Лобц	l2	lхв	Артикулы							
					STD 1795318	STD 1795400	STD 1795413	STD 1795401	STD 1795414	STD 1795411	STD 1795415	STD 1795412
11	25	600	500	70	•							
		800	700			•						
		1000	900				•					
		1200	1100					•				
		1400	1300						•			
		1600	1500							•		
		1800	1700								•	
2000	1900								•			
11,5	25	600	500	70	•							
		800	700			•						
		1000	900				•					
		1200	1100					•				
		1400	1300						•			
		1600	1500							•		
		1800	1700								•	
2000	1900								•			
12	25	600	500	70	•							
		800	700			•						
		1000	900				•					
		1200	1100					•				
		1400	1300						•			
		1600	1500							•		
		1800	1700								•	
2000	1900								•			
13	25	600	500	70	•							
		800	700			•						
		1000	900				•					
		1200	1100					•				
		1400	1300						•			
		1600	1500							•		
		1800	1700								•	
2000	1900								•			

пушечные сверла

СВЕРЛА ПУШЕЧНЫЕ

СВЕРХДЛИННЫЕ, ОДНОЛЕЗВИЙНЫЕ С НАПАЙНОЙ ТВЕРДОСПЛАВНОЙ ГОЛОВКОЙ

универсальное применение

Система обозначений	
d1	диаметр режущей части, мм
Лобц	общая длина, мм
l2	длина рабочей части, мм
dxв	Диаметр хвостовика, мм
lxв	длина хвостовика, мм

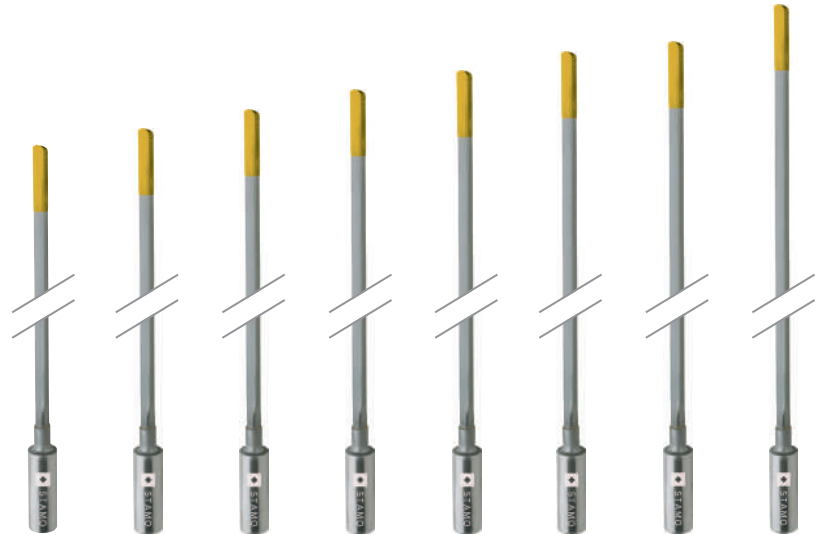
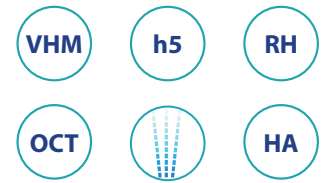
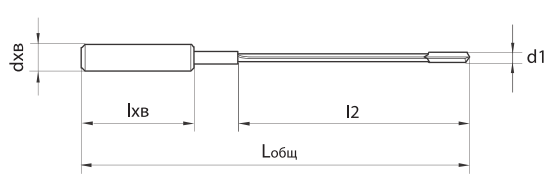

Глубина обработки		l=600	l=800	l=1000	l=1200	l=1400	l=1600	l=1800	l=2000			
Материал		VHM	VHM	VHM	VHM	VHM	VHM	VHM	VHM			
Покрытие		TIN	TIN	TIN	TIN	TIN	TIN	TIN	TIN			
Группы обрабатываемых материалов Основное применение	P	•	•	•	•	•	•	•	•			
	M	○	○	○	○	○	○	○	○			
	N	○	○	○	○	○	○	○	○			
	K	•	•	•	•	•	•	•	•			
	S	○	○	○	○	○	○	○	○			
	H	○	○	○	○	○	○	○	○			
d1	dxв	Лобц	l2	lxв	Артикулы							
					STD 1795318	STD 1795400	STD 1795413	STD 1795401	STD 1795414	STD 1795411	STD 1795415	STD 1795412
14	25	600	500	70	•							
		800	700			•						
		1000	900				•					
		1200	1100					•				
		1400	1300						•			
		1600	1500							•		
		1800	1700								•	
		2000	1900									•
15	25	600	500	70	•							
		800	700			•						
		1000	900				•					
		1200	1100					•				
		1400	1300						•			
		1600	1500							•		
		1800	1700								•	
		2000	1900									•
16	25	600	500	70	•							
		800	700			•						
		1000	900				•					
		1200	1100					•				
		1400	1300						•			
		1600	1500							•		
		1800	1700								•	
		2000	1900									•
17	25	600	500	70	•							
		800	700			•						
		1000	900				•					
		1200	1100					•				
		1400	1300						•			
		1600	1500							•		
		1800	1700								•	
		2000	1900									•

пушечные
сверла

СВЕРЛА ПУШЕЧНЫЕ



STAMO

СВЕРХДЛИННЫЕ, ОДНОЛЕЗВИЙНЫЕ С НАПАЙНОЙ ТВЕРДОСПЛАВНОЙ ГОЛОВКОЙ

универсальное применение

Система обозначений	
d1	диаметр режущей части, мм
Лобц	общая длина, мм
l2	длина рабочей части, мм
dxв	Диаметр хвостовика, мм
lxв	длина хвостовика, мм

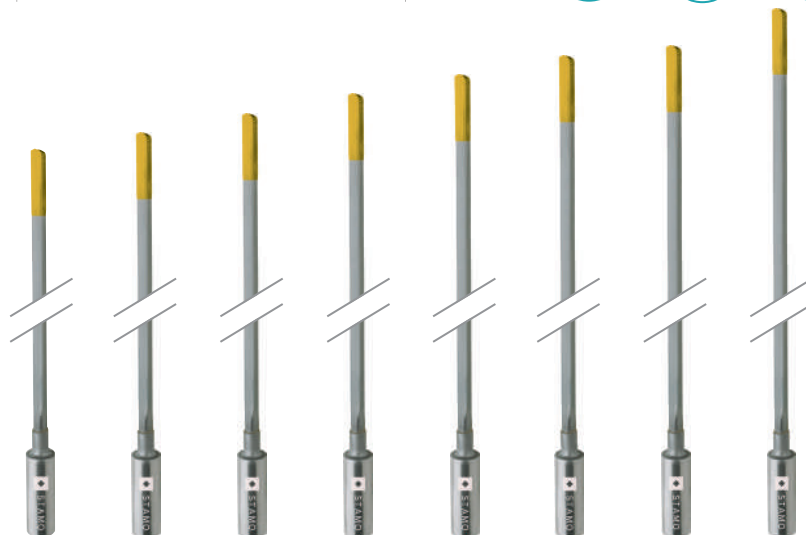
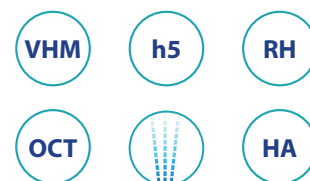
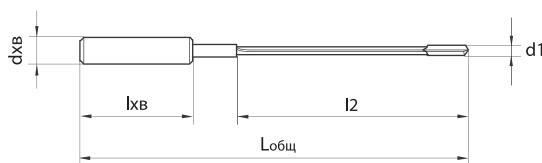

Глубина обработки		l=600	l=800	l=1000	l=1200	l=1400	l=1600	l=1800	l=2000			
Материал		VHM	VHM	VHM	VHM	VHM	VHM	VHM	VHM			
Покрытие		TIN	TIN	TIN	TIN	TIN	TIN	TIN	TIN			
Группы обрабатываемых материалов Основное применение	P	•	•	•	•	•	•	•	•			
	M	○	○	○	○	○	○	○	○			
	N	○	○	○	○	○	○	○	○			
	K	•	•	•	•	•	•	•	•			
	S	○	○	○	○	○	○	○	○			
	H	○	○	○	○	○	○	○	○			
d1	dxв	Лобц	l2	lxв	Артикулы							
					STD	STD	STD	STD	STD	STD	STD	
					1795318	1795400	1795413	1795401	1795414	1795411	1795415	1795412
18	25	600	500	70	•							
		800	700			•						
		1000	900				•					
		1200	1100					•				
		1400	1300						•			
		1600	1500							•		
		1800	1700								•	
	1900									•		
19	25	600	500	70	•							
		800	700			•						
		1000	900				•					
		1200	1100					•				
		1400	1300						•			
		1600	1500							•		
		1800	1700								•	
	1900									•		
20	25	600	500	70	•							
		800	700			•						
		1000	900				•					
		1200	1100					•				
		1400	1300						•			
		1600	1500							•		
		1800	1700								•	
	1900									•		
21	25	600	500	70	•							
		800	700			•						
		1000	900				•					
		1200	1100					•				
		1400	1300						•			
		1600	1500							•		
		1800	1700								•	
	1900									•		

пушечные сверла

СВЕРЛА ПУШЕЧНЫЕ



STAMO

СВЕРХДЛИННЫЕ, ОДНОЛЕЗВИЙНЫЕ С НАПАЙНОЙ ТВЕРДОСПЛАВНОЙ ГОЛОВКОЙ

универсальное применение

Система обозначений	
d1	диаметр режущей части, мм
Лобц	общая длина, мм
l2	длина рабочей части, мм
dxв	Диаметр хвостовика, мм
lxв	длина хвостовика, мм

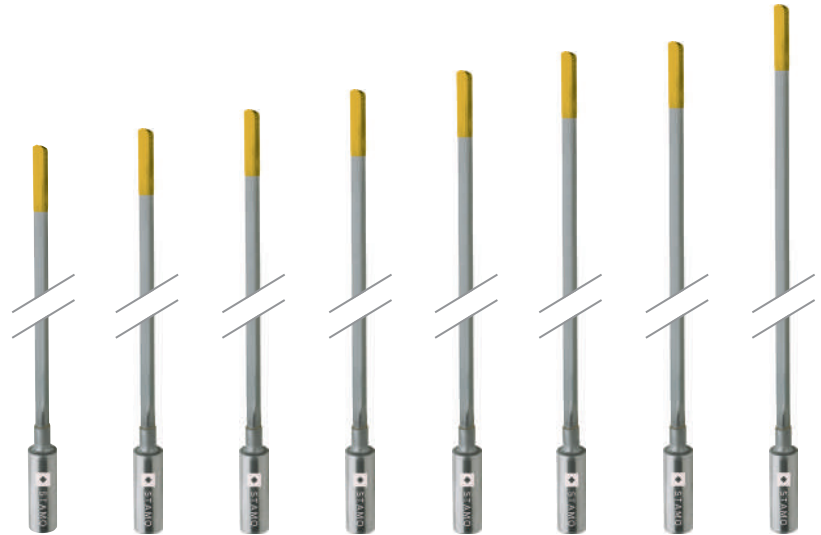
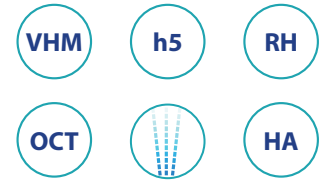
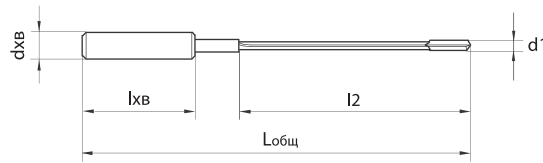

Глубина обработки		l=600	l=800	l=1000	l=1200	l=1400	l=1600	l=1800	l=2000			
Материал		VHM	VHM	VHM	VHM	VHM	VHM	VHM	VHM			
Покрытие		TIN	TIN	TIN	TIN	TIN	TIN	TIN	TIN			
Группы обрабатываемых материалов Основное применение	P	•	•	•	•	•	•	•	•			
	M	○	○	○	○	○	○	○	○			
	N	○	○	○	○	○	○	○	○			
	K	•	•	•	•	•	•	•	•			
	S	○	○	○	○	○	○	○	○			
	H	○	○	○	○	○	○	○	○			
d1	dxв	Лобц	l2	lxв	Артикулы							
					STD	STD	STD	STD	STD	STD	STD	
					1795318	1795400	1795413	1795401	1795414	1795411	1795415	1795412
22	25	600	500	70	•							
		800	700			•						
		1000	900				•					
		1200	1100					•				
		1400	1300						•			
		1600	1500							•		
		1800	1700								•	
		2000	1900									•
23	25	600	500	70	•							
		800	700			•						
		1000	900				•					
		1200	1100					•				
		1400	1300						•			
		1600	1500							•		
		1800	1700								•	
		2000	1900									•
24	25	600	500	70	•							
		800	700			•						
		1000	900				•					
		1200	1100					•				
		1400	1300						•			
		1600	1500							•		
		1800	1700								•	
		2000	1900									•
25	25	600	500	70	•							
		800	700			•						
		1000	900				•					
		1200	1100					•				
		1400	1300						•			
		1600	1500							•		
		1800	1700								•	
		2000	1900									•

пушечные сверла

СВЕРЛА ПУШЕЧНЫЕ



STAMO

СВЕРХДЛИННЫЕ, ОДНОЛЕЗВИЙНЫЕ С НАПАЙНОЙ ТВЕРДОСПЛАВНОЙ ГОЛОВКОЙ

универсальное применение

Система обозначений	
d1	диаметр режущей части, мм
Лобц	общая длина, мм
l2	длина рабочей части, мм
dxв	Диаметр хвостовика, мм
lхв	длина хвостовика, мм

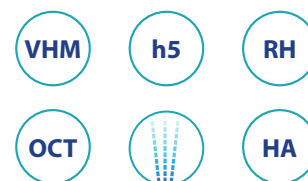
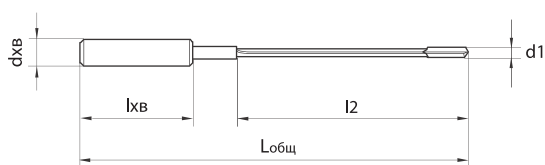

Глубина обработки		l=1800		l=2000		
Материал		VHM		VHM		
Покрытие		TIN		TIN		
Группы обрабатываемых материалов Основное применение	P	•	•	•	•	
	M	○	○	○	○	
	N	○	○	○	○	
	K	•	•	•	•	
	S	○	○	○	○	
	H	○	○	○	○	
d1	dxв	Лобц	l2	lхв		
		STD 1795415		STD 1795412		
26	25	1800	1700	70	•	
		2000	1900			•
1800		1700	•			
2000		1900			•	
27	25	1800	1700	70	•	
		2000	1900			•
28	25	1800	1700	70	•	
		2000	1900			•
1800		1700	•			
2000		1900			•	
29	25	1800	1700	70	•	
		2000	1900			•
30	25	1800	1700	70	•	
		2000	1900			•
1800		1700	•			
2000		1900			•	
31	25	1800	1700	70	•	
		2000	1900			•
32	25	1800	1700	70	•	
		2000	1900			•

пушечные сверла

ФРЕЗЕРНЫЙ ИНСТРУМЕНТ





ФРЕЗЫ ГРАВИРОВАЛЬНЫЕ ТВЕРДОСПЛАВНЫЕ	стр 156
ФРЕЗЫ ФАСОЧНЫЕ ТВЕРДОСПЛАВНЫЕ	стр 157
ФРЕЗЫ МНОГОФУНКЦИОНАЛЬНЫЕ	стр 158
ФРЕЗЫ VHM С ОБРАТНЫМ РАДИУСОМ ДЛЯ СКРУГЛЕНИЯ КРОМОК И СНЯТИЯ ЗАУСЕНЦЕВ	стр 159
ФРЕЗЫ HSSE С ОБРАТНЫМ РАДИУСОМ ДЛЯ СКРУГЛЕНИЯ КРОМОК И СНЯТИЯ ЗАУСЕНЦЕВ	стр 160
ФРЕЗЫ РЕЖИМЫ РЕЗАНИЯ: ФАСОЧНЫЕ ФРЕЗЫ ЧЕРНОВАЯ ОБРАБОТКА; ФАСОЧНЫЕ ФРЕЗЫ ЧИСТОВАЯ ОБРАБОТКА; МНОГОФУНКЦИОНАЛЬНЫЕ ФРЕЗЫ	стр 161
ФРЕЗЫ КОНЦЕВЫЕ ТРЕХЗУБЫЕ С ЦЕНТРАЛЬНЫМ РЕЗОМ	стр 162
ФРЕЗЫ ШПОНОЧНЫЕ ДВУХЗУБЫЕ С ЦЕНТРАЛЬНЫМ РЕЗОМ	стр 163
ФРЕЗЫ ПАЗОВЫЕ ТРЕХЗУБЫЕ С ЦЕНТРАЛЬНЫМ РЕЗОМ	стр 165
ФРЕЗЫ ШПОНОЧНЫЕ ФРЕЗЫ УНИВЕРСАЛЬНЫЕ	стр 166
ФРЕЗЫ ШПОНОЧНЫЕ ФРЕЗЫ ВЫСОКОПРОИЗВОДИТЕЛЬНЫЕ	стр 167
ФРЕЗЫ ШПОНОЧНЫЕ ФРЕЗЫ РАДИУСНЫЕ	стр 168
ФРЕЗЫ СФЕРИЧЕСКИЕ 2-Х И 4-ЗУБЫЕ DIN 6527L С ЦЕНТРАЛЬНЫМ РЕЗОМ	стр 173
ТЕХНИЧЕСКАЯ ЧАСТЬ РЕЖИМЫ РЕЗАНИЯ. ВЫСОКОПРОИЗВОДИТЕЛЬНОЕ ФРЕЗЕРОВАНИЕ	стр 174



VHM

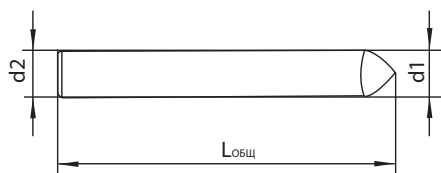

Система обозначений	
d1	диаметр режущей части, мм
d2	диаметр хвостовика, мм
Lобщ	общая длина, мм
l2	длина рабочей части, мм
Z	колво зубьев

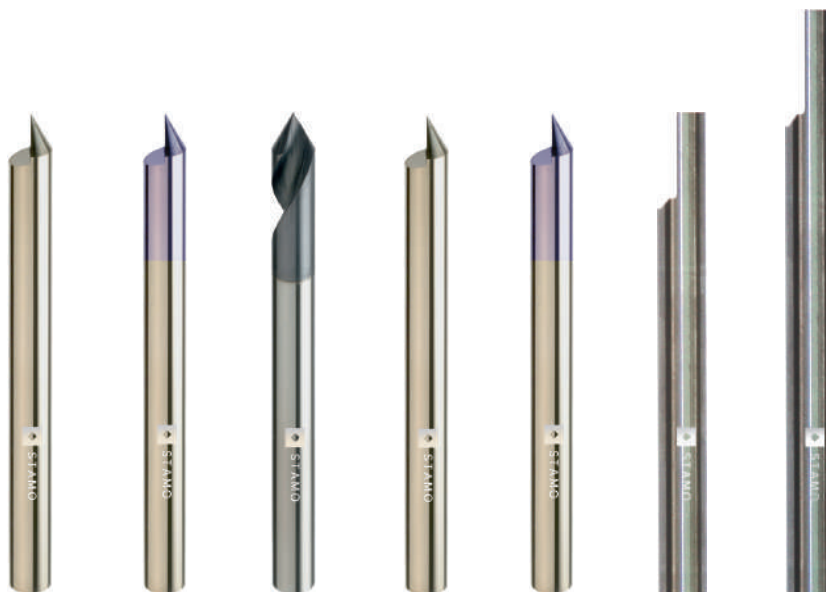

Угол при вершине				60°	60°	60°	90°	90°	60°	60°
Материал				VHM	VHM	VHM	VHM	VHM	VHM	VHM
Тип				OCT	OCT	spiralo 30°	OCT	OCT	заготовка	заготовка удл.
Покрытие				BR	TiAlN	STB	BR	TiAlN	BR	BR
Группы обрабатываемых материалов. Основное применение				P	•	•	•	•	•	•
				N	•	•	•	•	•	•
d1/d2	Lобщ	l2	Z	Артикулы						
				STM9062	STM9063	STM9066	STM9064	STM9065	STM9060	STM9061
2	50	3	1	•	•			•	•	
2,5	50	3	1	•	•			•	•	
3	50	4	1	•	•	•	•	•	•	
4	50	5	1	•	•	•	•	•	•	
5	50	6	1	•	•		•	•	•	
6	50	6	1	•	•	•	•	•	•	
8	50	8	1	•	•		•	•	•	
10	50	10	1						•	
10	60	15	1	•	•		•	•		
12	50	12	1						•	
12	60	18	1	•	•		•	•		
DIN6535L										
5	100	6	1							•
6	100	6	1							•
8	100	8	1							•
10	100	10	1							•
12	100	12	1							•

РЕЖИМЫ РЕЗАНИЯ

Группы обрабатываемых материалов		Vc м/мин	fz mm/Z	fz mm/Z	fz mm/Z	Vc м/мин	fz mm/Z	fz mm/Z
			d2-d6	d6-d10	d10-d16		d3-d4	d4-d6
		STM9062, STM9063, STM9064, STM9065					STM9066	
P	стали <500 Н/мм ²	60-80	0,007-0,010	0,010-0,020	0,020-0,030	70-90	0,007-0,010	0,020-0,030
	стали <700 Н/мм ²	65-85	0,007-0,010	0,010-0,020	0,020-0,030	75-95	0,007-0,010	0,020-0,030
	стали <850 Н/мм ²	50-70	0,007-0,010	0,010-0,020	0,020-0,030	60-80	0,007-0,010	0,020-0,030
	стали <1000 Н/мм ²	45-65	0,007-0,010	0,010-0,020	0,020-0,030	55-75	0,007-0,010	0,020-0,030
	стали <1400 Н/мм ²	25-40	0,007-0,010	0,010-0,020	0,020-0,030	35-50	0,007-0,010	0,020-0,030
	цементируемые стали <1000 Н/мм ²	40-60	0,007-0,010	0,010-0,020	0,020-0,030	50-70	0,007-0,010	0,020-0,030
	азотированные стали <1000 Н/мм ²	40-60	0,007-0,010	0,010-0,020	0,020-0,030	50-70	0,007-0,010	0,020-0,030
N	термообрабатываемые стали	40-60	0,007-0,010	0,010-0,020	0,020-0,030	50-70	0,007-0,010	0,020-0,030
	Al и Al сплавы <6% Si	165-185	0,007-0,010	0,010-0,020	0,020-0,030	175-195	0,007-0,010	0,020-0,030
	Al и Al сплавы <12% Si	130-150	0,007-0,010	0,010-0,020	0,020-0,030	140-160	0,007-0,010	0,020-0,030
	Al и Al сплавы >12% Si	90-110	0,007-0,010	0,010-0,020	0,020-0,030	100-120	0,007-0,010	0,020-0,030
	Бронза, медь, латунь	80-100	0,007-0,010	0,010-0,020	0,020-0,030	90-110	0,007-0,010	0,020-0,030
	Дюро/Термопластики	170-200	0,007-0,010	0,010-0,020	0,020-0,030	180-210	0,007-0,010	0,020-0,030

ФАСОЧНЫЕ ТВЕРДОСПЛАВНЫЕ ФРЕЗЫ

60°, 90°, 120°

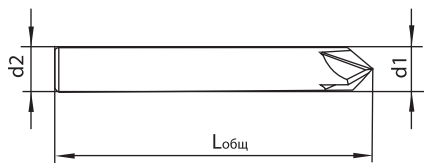

Система обозначений	
d1	диаметр режущей части, мм
d2	диаметр хвостовика, мм
Лобщ	общая длина, мм
Z	кол-во зубьев



Угол при вершине	60°	60°	60°	60°	60°	90°	90°	90°	90°	90°	120°	120°		
Материал	VHM	VHM	VHM	VHM	VHM	VHM	VHM	VHM	VHM	VHM	VHM	VHM		
Тип					XL					XL				
Хвостовик	HB (d2≤4мм HA)	HA	HB	HB	HA	HB (d2≤4мм HA)	HB (d2≤4мм HA)	HA	HB (d2≤6мм HA)	HA	HB	HA		
Покрытие	ALTiN	ALTiN	ALTiN	BR	STB	ALTiN	ALTiN	ALTiN	BR	STB	ALTiN	ALTiN		
Группы обрабатываемых материалов. Основное применение	P	•	•	•	•	•	•	•	•	•	•	•		
	M	•	•	•	•	•	•	•	•	•	•	•		
	N	•	•	•	•	•	•	•	•	•	•	•		
	K	•	•	•	•	•	•	•	•	•	•	•		
	S	•	•	•	•	•	•	•	•	•	•	•		
H	o	o	o		o	o	o	o	o	o	o	o		
d1/d2	Лобщ	Z	Артикулы											
			STM9600	STM9601	STM9603	STM9602	STM9604	STM9901	STM9903	STM9900	STM9904	STM9905	STM9121	STM9120
1	38	3						•			•			
3								•						
3	38	4						•		•				
4	50	4		•						•			•	
	54		•		•			•	•	•				
6	57	4	•	•		•		•	•	•		•	•	
		5	•	•		•		•	•	•				
8	63	4			•			•	•	•		•	•	
		6	•	•		•		•	•	•		•	•	
10	72	4			•			•	•	•		•	•	
		6	•	•		•		•	•	•		•	•	
12	83	4			•			•	•	•		•	•	
		6	•	•		•		•	•	•		•	•	
16	92	4			•			•	•	•		•	•	
		6	•	•		•		•	•	•		•	•	
20	104	4			•			•	•	•		•	•	
		6	•	•		•		•	•	•		•	•	
ОСТ														
4	100	4										•		
6	110	4					•					•		
8	150	5					•					•		
10		6					•					•		
12		6					•					•		

фрезы

универсальное применение

Система обозначений	
d1 h9	диаметр режущей части, мм
dxв. h6	диаметр хвостовика, мм
Лобщ	общая длина, мм
l2	длина режущей части, мм

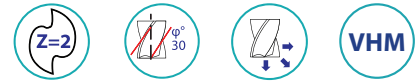
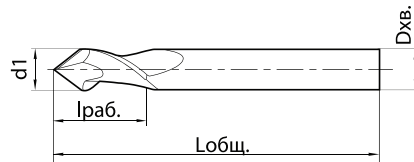

Угол при вершине, ф°	60°	60°	90°	90°	120°	120°				
Материал	VHM	VHM	VHM	VHM	VHM	VHM				
Покрытие	Pol	TiAlN	Pol	TiAlN	Pol	TiAlN				
Исполнение хвостовика	HA	HA	HA	HA	HA	HA				
Группы обрабатываемых материалов	P	•	•	•	•	•				
	M	•	•	•	•	•				
	N	•	○	•	○	•				
	K	•	•	•	•	•				
d1h9	dxв. h6	Лобщ	l2	Z	Артикулы					
					STM9793	STM9794	STM9763	STM9764	STM9712	STM9713
0,5	3	39	1	2	•		•			
0,7			1,4		•		•			
1			2		•		•			
1,5			3		•		•			
1,8			3,6		•		•			
2	4	•			•					
2,5	5	•			•					
3	6	•			•					
4	5	50	8		•		•		•	•
5	6		10		•		•		•	•
6	8		12		•		•		•	•
8	10		16		•		•		•	•
10	12		18		•		•		•	•
12	12	90	20		•		•		•	•
16	16	92	26		•		•		•	•
20	20	100	32	•		•		•	•	

Pol - шлифованная стружечная канавка для уменьшения коэффициента трения.

ВОЗМОЖНОСТИ ИНСТРУМЕНТА

Многофункциональные фрезы

1 Фрезерование методом круговой интерполяции

2 Центрирование отверстий

3 Торцевое фрезерование

4 Снятие фаски, фрезерование наклонной поверхности

5 Фрезерование V-образных пазов

6 Зенкерование

7 Комбинированное торцевое фрезерование и фрезерование наклонной поверхности

8 Сверление отверстий

9 Гравирование

ФРЕЗЫ VHM С ОБРАТНЫМ РАДИУСОМ



ДЛЯ СКРУГЛЕНИЯ КРОМОК И СНЯТИЯ ЗАУСЕНЦЕВ

универсальное применение

Система обозначений	
R	радиус скругления
d1	диаметр носика, мм
d2 хв	диаметр хвостовика, мм
Лобц	общая длина, мм
Z	ко-во зубьев

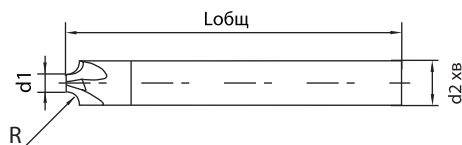

Материал	VHM		VHM		VHM		VHM		
Покрытие	BR		TiAlN		BR		TiAlN		
Исполнение хвостовика	HA		HA		HA		HA		
Группы обрабатываемых материалов	P	•	•	•	•	•	•	•	
	M	•	•	•	•	•	•	•	
	N	•	•	•	•	•	•	•	
	K	•	•	•	•	•	•	•	
	S	•	•	•	•	•	•	•	
R +/- 0,01 мм	d1	Лобц	d2 хв	Z	Артикулы				
					STM9401		STM9400		
0,2	5,6	58	6	4	•	•			
0,3	5,4	58	6	4	•	•			
0,5	7	70	8	4	•	•			
1	6	70	8	4	•	•			
1,5	7	70	10	4	•	•			
2	6	75	10	4	•	•			
2,5	7	75	12	4	•	•			
3	6	75	12	4	•	•			
3,5	9	80	16	4	•	•			
4	8	80	16	4	•	•			
4,5	7	80	16	4	•	•			
5	10	80	20	4	•	•			
6	8	80	20	4	•	•			
8	9	100	25	4	•	•			
10	5	100	25	4	•	•			
МИКРОФРЕЗЫ С ОБРАТНЫМ РАДИУСОМ							STM9402	STM9403	
0,2	1	50	3	2			•	•	
0,25	1,1	50	3	2			•	•	
0,3	1,2	50	3	2			•	•	
0,4	1,4	50	3	2			•	•	
0,5	1,6	50	3	2			•	•	
0,6	1,8	50	3	2			•	•	
0,7	2	50	3	2			•	•	
0,8	2,5	50	3	2			•	•	
1	2,9	50	3	2			•	•	
1,25	3,4	50	4	2			•	•	
1,5	4,6	50	5	2			•	•	
2	5,6	50	6	2			•	•	

Пример заказа фрезы без покрытия с радиусом R=3: **STM9401 R3**

Режимы резания. Фрезы твердосплавные с обратным радиусом

Группы обрабатываемых материалов	Vc м/мин	fz мм/Z	fz мм/Z	fz мм/Z	fz мм/Z	fz мм/Z
		<d6	d6-d10	d10-d16	d16-d20	d20-d25
P	стали <500 Н/мм ²	180-200	0,001-0,003	0,003-0,012	0,012-0,025	0,025-0,032
	стали <700 Н/мм ²	160-180	0,001-0,003	0,003-0,012	0,012-0,025	0,025-0,032
	стали <850 Н/мм ²	150-170	0,001-0,003	0,003-0,012	0,012-0,025	0,025-0,032
	стали <1000 Н/мм ²	110-130	0,001-0,003	0,003-0,012	0,012-0,025	0,025-0,032
	стали <1400 Н/мм ²	75-95	0,001-0,003	0,003-0,010	0,010-0,025	0,022-0,030
	цементируемые стали <1000 Н/мм ²	110-130	0,001-0,003	0,003-0,012	0,012-0,025	0,025-0,032
	азотированные стали <1000 Н/мм ²	110-130	0,001-0,003	0,003-0,012	0,012-0,025	0,025-0,032
M	термообрабатываемые стали <850 Н/мм ²	130-150	0,001-0,003	0,003-0,012	0,012-0,025	0,025-0,032
	инструментальные стали	75-100	0,001-0,003	0,003-0,012	0,012-0,025	0,025-0,032
K	нержавеющие и кислотостойкие стали <700 Н/мм ²	100-120	0,001-0,003	0,003-0,010	0,010-0,022	0,022-0,030
	нержавеющие и кислотостойкие стали >700 Н/мм ²	70-90	0,001-0,003	0,003-0,010	0,010-0,022	0,022-0,030
N	серый чугун <180 НВ	120-160	0,001-0,003	0,003-0,012	0,012-0,025	0,025-0,032
	ковкий чугун	80-110	0,001-0,003	0,003-0,012	0,012-0,025	0,025-0,032
	чугун с шаровидным графитом	80-110	0,001-0,003	0,003-0,012	0,012-0,025	0,025-0,032
S	Al и Al сплавы <6% Si	550-650	0,001-0,003	0,003-0,012	0,012-0,025	0,025-0,032
	Al и Al сплавы <12% Si	450-550	0,001-0,003	0,003-0,012	0,012-0,025	0,025-0,032
	Al и Al сплавы >12% Si	350-450	0,001-0,003	0,003-0,012	0,012-0,025	0,025-0,032
	Бронза, медь, латунь	270-320	0,001-0,003	0,003-0,012	0,012-0,025	0,025-0,032
S	Титан, сплавы титана, никель, никелевые сплавы	50-70	0,001-0,003	0,003-0,010	0,010-0,022	0,022-0,030

фрезы

ФРЕЗЫ HSSE С ОБРАТНЫМ РАДИУСОМ

ДЛЯ СКРУГЛЕНИЯ КРОМОК И СНЯТИЯ ЗАУСЕНЦЕВ

универсальное применение

Система обозначений	
R	радиус скругления
d1	диаметр носика, мм
d3	диаметр рабочей части, мм
d2 хв	диаметр хвостовика, мм
Лобц	общая длина, мм
Z	ко-во зубьев

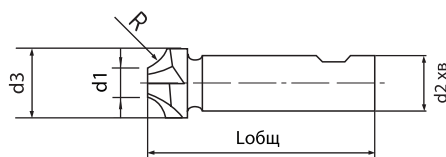

Материал						HSSE	HSSE
Покрытие						BR	TAIN
Исполнение хвостовика						HB	HB
Группы обрабатываемых материалов						P	•
						N	•
						K	•
R H11	d1	d3	Лобц	d2 хв. h6	Z	Артикулы	
						STM90952	STM90953
1	6	8	60	10	4	•	
1,25	6	8	60	10	4	•	
1,5	6	9	60	10	4	•	
1,6	6	9,2	60	10	4	•	
2	6	10	60	10	4	•	
2,5	6	11	60	10	4	•	
3	6	12	60	12	4	•	
3,5	6	13	60	12	4	•	
4	6	14	60	12	4	•	
4,5	6	15	60	12	4	•	
5	6	16	60	12	4	•	
5,5	8	19	67	16	4	•	
6	8	20	67	16	4	•	•
6,5	8	21	71	16	4	•	•
7	8	22	71	16	4	•	•
7,5	8	23	71	16	4	•	•
8	8	24	71	16	4	•	•
8,5	8	25	85	25	4	•	•
9	8	26	85	25	4	•	•
9,5	8	27	85	25	4	•	•
10	8	28	85	25	4	•	•
10,5	10	31	90	25	4	•	•
11	10	32	90	25	4	•	•
12	10	34	90	25	4	•	•
12,5	16	41	100	25	6	•	•
13	16	42	100	25	6	•	•
14	16	44	100	25	6	•	•
15	16	46	100	25	6	•	•
16	16	48	100	25	6	•	•
17	16	50	112	32	6	•	•
18	16	52	112	32	6	•	•
19	18	56	18	32	6	•	•
20	16	56	112	32	6	•	•

Пример заказа фрезы без покрытия с радиусом R=6: **STM90952 R6**

Режимы резания. Фрезы HSSE с обратным радиусом $ap=0,1xD / ae=0,1xD$

Группы обрабатываемых материалов		Vc м/мин	fz мм/З <d6	fz мм/З d6-d10	fz мм/З d10-d16	fz мм/З d16-d20	fz мм/З d20-d25
P	стали <500 Н/мм ²	25-35	0,001-0,003	0,003-0,012	0,012-0,025	0,025-0,032	0,032-0,045
	стали <700 Н/мм ²	20-30	0,001-0,003	0,003-0,012	0,012-0,025	0,025-0,032	0,032-0,045
	стали <850 Н/мм ²	20-25	0,001-0,003	0,003-0,012	0,012-0,025	0,025-0,032	0,032-0,045
K	серый чугун <180 HB	20-30	0,001-0,003	0,003-0,012	0,012-0,025	0,025-0,032	0,032-0,045
	ковкий чугун	20-30	0,001-0,003	0,003-0,012	0,012-0,025	0,025-0,032	0,032-0,045
N	Al и Al сплавы <6% Si	100-150	0,001-0,003	0,003-0,012	0,012-0,025	0,025-0,032	0,032-0,045
	Al и Al сплавы <12% Si	60-100	0,001-0,003	0,003-0,012	0,012-0,025	0,025-0,032	0,032-0,045
	Бронза, медь, латунь	45-70	0,001-0,003	0,003-0,012	0,012-0,025	0,025-0,032	0,032-0,045

Фасочные фрезы черновая обработка

Группы обрабатываемых материалов		Vc м/мин	фz мм/З	фz мм/З	фz мм/З	фz мм/З	фz мм/З
			d1 - d4	d4 - d8	d8 - d12	d12 - d16	d16 - d20
P	стали <500 Н/мм ²	120	0,010-0,030	0,030-0,060	0,060-0,100	0,100-0,120	0,120-0,140
	стали <700 Н/мм ²	105	0,010-0,030	0,030-0,060	0,060-0,100	0,100-0,120	0,120-0,140
	стали <850 Н/мм ²	95	0,010-0,030	0,030-0,060	0,060-0,100	0,100-0,120	0,120-0,140
	стали <1000 Н/мм ²	90	0,010-0,030	0,030-0,060	0,060-0,100	0,100-0,120	0,120-0,140
	стали <1400 Н/мм ²	80	0,010-0,020	0,020-0,040	0,040-0,070	0,070-0,090	0,090-0,100
	цементируемые стали <1000 Н/мм ²	80	0,010-0,020	0,020-0,040	0,040-0,070	0,070-0,100	0,100-0,100
	азотированные стали <1000 Н/мм ²	80	0,010-0,020	0,020-0,040	0,040-0,070	0,070-0,100	0,100-0,100
	термообрабатываемые стали <850 Н/мм ²	100	0,010-0,020	0,020-0,040	0,040-0,070	0,070-0,100	0,100-0,100
M	инструментальные стали	70	0,010-0,020	0,020-0,040	0,040-0,070	0,070-0,090	0,090-0,100
	нержавеющие и кислотостойкие стали <700 Н/мм ²	80	0,005-0,015	0,015-0,030	0,030-0,040	0,040-0,050	0,050-0,060
K	нержавеющие и кислотостойкие стали >700 Н/мм ²	60	0,005-0,010	0,010-0,030	0,030-0,040	0,040-0,050	0,050-0,060
	серый чугун <180 НВ	120	0,010-0,020	0,020-0,040	0,040-0,060	0,060-0,070	0,070-0,090
	ковкий чугун	60	0,010-0,030	0,030-0,050	0,050-0,070	0,070-0,090	0,090-0,120
N	чугун с шаровидным графитом	90	0,010-0,030	0,030-0,050	0,050-0,070	0,070-0,090	0,090-0,120
	Al и Al сплавы <6% Si	300	0,010-0,030	0,030-0,060	0,060-0,100	0,100-0,120	0,120-0,140
	Al и Al сплавы <12% Si	280	0,010-0,030	0,030-0,060	0,060-0,100	0,100-0,120	0,120-0,140
	Al и Al сплавы >12% Si	200	0,010-0,030	0,030-0,060	0,060-0,100	0,100-0,120	0,120-0,140
S	Бронза, медь, латунь	200	0,010-0,030	0,030-0,060	0,060-0,100	0,100-0,120	0,120-0,140
S	Титан, сплавы титана, никель, никелевые сплавы	40	0,005-0,015	0,015-0,030	0,030-0,060	0,060-0,070	0,070-0,090

Фасочные фрезы чистовая обработка

Группы обрабатываемых материалов		Vc м/мин	фz мм/З	фz мм/З	фz мм/З	фz мм/З	фz мм/З
			d1 - d4	d4 - d8	d8 - d12	d12 - d16	d16 - d20
P	стали <500 Н/мм ²	190	0,020-0,040	0,040-0,070	0,070-0,120	0,120-0,150	0,150-0,170
	стали <700 Н/мм ²	170	0,020-0,040	0,040-0,070	0,070-0,120	0,120-0,150	0,150-0,170
	стали <850 Н/мм ²	170	0,020-0,040	0,040-0,070	0,070-0,120	0,120-0,150	0,150-0,170
	стали <1000 Н/мм ²	140	0,020-0,040	0,040-0,070	0,070-0,120	0,120-0,150	0,150-0,170
	стали <1400 Н/мм ²	85	0,010-0,020	0,020-0,040	0,040-0,060	0,060-0,080	0,080-0,120
	цементируемые стали <1000 Н/мм ²	120	0,010-0,020	0,020-0,050	0,050-0,070	0,070-0,100	0,100-0,130
	азотированные стали <1000 Н/мм ²	120	0,010-0,020	0,020-0,050	0,050-0,070	0,070-0,100	0,100-0,130
	термообрабатываемые стали <850 Н/мм ²	160	0,010-0,030	0,030-0,050	0,050-0,070	0,070-0,100	0,100-0,130
M	инструментальные стали	95	0,010-0,020	0,020-0,040	0,040-0,060	0,060-0,080	0,080-0,120
	нержавеющие и кислотостойкие стали <700 Н/мм ²	110	0,010-0,020	0,020-0,040	0,040-0,050	0,050-0,070	0,070-0,080
K	нержавеющие и кислотостойкие стали >700 Н/мм ²	75	0,010-0,020	0,020-0,030	0,030-0,040	0,040-0,060	0,060-0,080
	серый чугун <180 НВ	150	0,010-0,030	0,030-0,040	0,040-0,070	0,070-0,080	0,080-0,100
	ковкий чугун	70	0,020-0,040	0,040-0,060	0,060-0,090	0,090-0,120	0,120-0,150
N	чугун с шаровидным графитом	100	0,020-0,040	0,040-0,060	0,060-0,090	0,090-0,120	0,120-0,150
	Al и Al сплавы <6% Si	700	0,020-0,040	0,040-0,070	0,070-0,120	0,120-0,150	0,150-0,170
	Al и Al сплавы <12% Si	700	0,020-0,040	0,040-0,070	0,070-0,120	0,120-0,150	0,150-0,170
	Al и Al сплавы >12% Si	40	0,020-0,040	0,040-0,070	0,070-0,120	0,120-0,150	0,150-0,170
S	Бронза, медь, латунь	300	0,020-0,040	0,040-0,070	0,070-0,120	0,120-0,150	0,150-0,170
S	Титан, сплавы титана, никель, никелевые сплавы	60	0,010-0,020	0,020-0,040	0,040-0,070	0,070-0,090	0,090-0,110

Многофункциональные фрезы

Группы обрабатываемых материалов		Vc м/мин	f мм/об	f мм/об	f мм/об	f мм/об	f мм/об
			d0,5 - d4	d4 - d8	d8 - d12	d12 - d16	d16 - d20
P	стали <500 Н/мм ²	60-80	0,030-0,050	0,050-0,120	0,120-0,180	0,180-0,250	0,250-0,300
	стали <700 Н/мм ²	60-70	0,030-0,050	0,050-0,120	0,120-0,180	0,180-0,250	0,250-0,300
	стали <850 Н/мм ²	60-70	0,030-0,050	0,050-0,120	0,120-0,180	0,180-0,250	0,250-0,300
	стали <1000 Н/мм ²	40-50	0,025-0,045	0,045-0,100	0,120-0,160	0,160-0,220	0,220-0,260
M	нержавеющие и кислотостойкие стали <700 Н/мм ²	30-50	0,025-0,045	0,045-0,100	0,120-0,160	0,160-0,220	0,220-0,260
	нержавеющие и кислотостойкие стали >700 Н/мм ²	25-40	0,025-0,045	0,045-0,100	0,120-0,160	0,160-0,220	0,220-0,260
K	серый чугун <180 НВ	50-60	0,025-0,045	0,045-0,100	0,120-0,160	0,160-0,220	0,220-0,260
	ковкий чугун	50-60	0,025-0,045	0,045-0,100	0,120-0,160	0,160-0,220	0,220-0,260
N	Al и Al сплавы <6% Si	180-200	0,030-0,050	0,050-0,150	0,150-0,200	0,020-0,280	0,280-0,350
	Al и Al сплавы <12% Si	130-180	0,030-0,050	0,050-0,150	0,150-0,200	0,020-0,280	0,280-0,350
	Al и Al сплавы >12% Si	100-120	0,030-0,050	0,050-0,120	0,120-0,180	0,180-0,250	0,250-0,350



для алюминия и других
цветных металлов

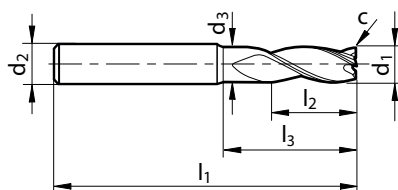

Система обозначений	
Ød1 e8	диаметр режущей части, мм
Ød2 h6	диаметр хвостовика, мм
Ød3	диаметр шейки, мм
L ₁	длина общая, мм
L ₂	длина режущей части, мм
L ₃	длина обניжения, мм
c	фаска, мм x 45°
γ	передний угол, °
Z	кол-во зубьев



Глубина обработки	M	M	M	L	L	XL	XL
Угол подъема спирали, φ°	39/40/41	39/40/41	45	39/40/41	39/40/41	39/40/41	39/40/41
Материал	10	10	10	10	10	10	VHM
Покрывтие	Pol	Pol	Pol	Pol	Pol	Pol	Pol
Передний угол, γ°	10	10	10	10	10	10	10
Исполнение хвостовика	HA	HB	HA	HA	HB	HA	HB
Кол-во зубьев	3	3	3	3	3	3	3
	N	N	N	N	N	N	N
Группы обрабатываемых материалов							

Ød1 e8	Ød1 h6	Ød3	L ₁	L ₂	L ₃	c	Артикулы						
							STM4320	STM4321	STM4322	STM4340	STM4341	STM4350	STM4351
3,0	6,0	2,8	57,0	8,0	15,0	0,06	•	•					
4,0	6,0	3,8	57,0	11,0	18,0	0,08	•	•					
5,0	6,0	4,8	57,0	13,0	18,0	0,10	•	•					
6,0	6,0	5,7	57,0	13,0	20,0	0,12	•	•					
8,0	8,0	7,7	63,0	19,0	26,0	0,16	•	•					
10,0	10,0	9,5	72,0	22,0	30,0	0,20	•	•					
12,0	12,0	11,5	83,0	26,0	36,0	0,24	•	•					
16,0	16,0	15,5	92,0	32,0	42,0	0,32	•	•					
20,0	20,0	19,5	104,0	38,0	52,0	0,20	•	•					
DIN 6527 L													
6,0	6,0	-	60,0	16,0	-	-			•				
8,0	8,0	-	78,0	25,0	-	-			•				
10,0	10,0	-	78,0	28,0	-	-			•				
12,0	12,0	-	89,0	32,0	-	-			•				
14,0	14,0	-	89,0	32,0	-	-			•				
16,0	16,0	-	92,0	35,0	-	-			•				
20,0	20,0	-	110,0	45,0	-	-			•				
25,0	25,0	-	121,0	50,0	-	-			•				
DIN 6527 L													
6,0	6,0	5,5	65,0	13,0	28,0	0,12				•	•		
8,0	8,0	7,5	75,0	19,0	38,0	0,16				•	•		
10,0	10,0	9,2	80,0	22,0	38,0	0,20				•	•		
12,0	12,0	11,2	93,0	26,0	46,0	0,24				•	•		
16,0	16,0	15,0	108,0	32,0	58,0	0,32				•	•		
20,0	20,0	19,0	126,0	38,0	74,0	0,20				•	•		
DIN 6527 L													
6,0	6,0	-	65,0	24,0	29,0	0,06						•	•
8,0	8,0	-	75,0	32,0	39,0	0,08						•	•
10,0	10,0	-	100,0	40,0	60,0	0,10						•	•
12,0	12,0	-	100,0	48,0	55,0	0,12						•	•
16,0	16,0	-	125,0	64,0	77,0	0,16						•	•
20,0	20,0	-	150,0	80,0	100,0	0,20						•	•

ФРЕЗЫ ШПОНОЧНЫЕ



STAMO

ДВУХЗУБЫЕ С ЦЕНТРАЛЬНЫМ РЕЗОМ

для алюминия и других
цветных металлов



Система обозначений	
Ød1 e8	диаметр режущей части, мм
Ød2 h6	диаметр хвостовика, мм
L ₁	длина общая, мм
L ₂	длина режущей части, мм
L ₃	длина обniżения, мм
c	фаска, мм x 45°
γ	передний угол, °
Z	кол-во зубьев

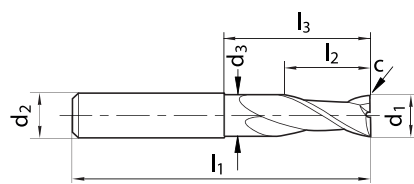

Глубина обработки	M	M	M	M	M
Угол подъема спирали, φ°	45	45	55	45	45
Материал	VHM	VHM	VHM	VHM	VHM
Покрытие	Pol	Pol	Pol	ZrN	ZrN
Передний угол, γ°	25	25	25	25	25
Исполнение хвостовика	HA	HB	HB	HA	HB
Кол-во зубьев	2	2	2	2	2
Группы обрабатываемых материалов	N	N	N	N	N

Ød1 e8	Ød2 h6	L ₁	L ₂	L ₃	c	Артикулы				
						STM4220	STM4221	STM4233	STM4230	STM4231
3,0	6,0	57,0	7,0	21,0	0,03	•	•			
4,0	6,0	57,0	8,0	21,0	0,03	•	•			
5,0	6,0	57,0	10,0	21,0	0,03	•	•			
6,0	6,0	57,0	10,0	21,0	0,03	•	•			
8,0	8,0	63,0	16,0	27,0	0,05	•	•			
10,0	10,0	72,0	19,0	32,0	0,05	•	•			
12,0	12,0	83,0	22,0	38,0	0,10	•	•			
14,0	14,0	83,0	22,0	38,0	0,10	•	•			
16,0	16,0	92,0	26,0	44,0	0,10	•	•			
18,0	18,0	92,0	26,0	44,0	0,10	•	•			
20,0	20,0	104,0	32,0	54,0	0,10	•	•			
2,0	6,0	57,0	8,0	16,0	0,05				•	•
3,0	6,0	57,0	8,0	18,0	0,1			•	•	•
4,0	6,0	57,0	11,0	18,0	0,1			•	•	•
5,0	6,0	57,0	13,0	20,0	0,1			•	•	•
6,0	6,0	57,0	13,0	20,0	0,1			•	•	•
8,0	8,0	63,0	19,0	26,0	0,1			•	•	•
10,0	10,0	72,0	22,0	29,0	0,1			•	•	•
12,0	12,0	83,0	26,0	36,0	0,1			•	•	•
14,0	14,0	83,0	26,0	36,0	0,1			•	•	•
16,0	16,0	92,0	32,0	42,0	0,1			•	•	•
18,0	18,0	92,0	32,0	42,0	0,1			•	•	•
20,0	20,0	104,0	38,0	52,0	0,1			•	•	•

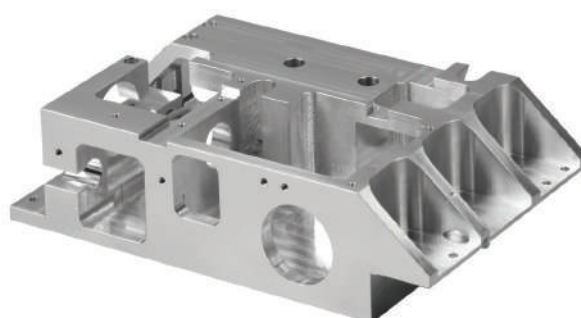

фрезы

ФРЕЗЫ ШПОНОЧНЫЕ

ДВУХЗУБЫЕ С ЦЕНТРАЛЬНЫМ РЕЗОМ

универсальное применение
R ≤ 1200 Н/мм²

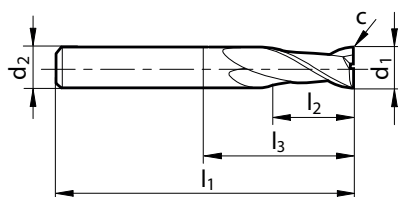

Система обозначений	
Ød1 h10	диаметр режущей части, мм
Ød2 h6	диаметр хвостовика, мм
L ₁	длина общая, мм
L ₂	длина режущей части, мм
L ₃	длина обniżения, мм
c	фаска, мм x 45°
γ	передний угол, °
Z	кол-во зубьев



Глубина обработки	S	S	M	M	XL
Угол подъема спирали, φ°	30	30	30	30	30
Материал	VHM	VHM	VHM	VHM	VHM
Покрытие					
Передний угол, γ°	9	9	9	9	9
Исполнение хвостовика	HA	HB	HA	HB	HA
Кол-во зубьев	2	2	2	2	2
Группы обрабатываемых материалов	P	P	P	P	P
	M	M	M	M	M
	K	K	K	K	K

Ød1 h10	Ød1 h6	L ₁	L ₂	L ₃	c	Артикулы				
						STM3210	STM3211	STM3220	STM3221	STM3240
2,0	6,0	50,0	3,0	14,0	0,025	•	•	•	•	•
2,5	6,0	50,0	3,0	14,0	0,050	•	•	•	•	•
3,0	6,0	50,0	4,0	14,0	0,050	•	•	•	•	•
4,0	6,0	54,0	5,0	18,0	0,050	•	•	•	•	•
5,0	6,0	54,0	6,0	18,0	0,050	•	•	•	•	•
6,0	6,0	54,0	7,0	18,0	0,050	•	•	•	•	•
6,5	8,0	58,0	8,0	22,0	0,100	•	•	•	•	•
8,0	8,0	58,0	9,0	22,0	0,100	•	•	•	•	•
10,0	10,0	66,0	11,0	26,0	0,100	•	•	•	•	•
12,0	12,0	73,0	12,0	28,0	0,100	•	•	•	•	•
14,0	14,0	75,0	14,0	30,0	0,150	•	•	•	•	•
16,0	16,0	82,0	16,0	34,0	0,150	•	•	•	•	•
18,0	18,0	84,0	18,0	36,0	0,150	•	•	•	•	•
20,0	20,0	92,0	20,0	42,0	0,150	•	•	•	•	•
2,0	6,0	57,0	6,0	21,0	0,025	•	•	•	•	•
3,0	6,0	57,0	7,0	21,0	0,050	•	•	•	•	•
4,0	6,0	57,0	8,0	21,0	0,050	•	•	•	•	•
5,0	6,0	57,0	10,0	21,0	0,050	•	•	•	•	•
6,0	6,0	57,0	10,0	21,0	0,050	•	•	•	•	•
8,0	8,0	63,0	16,0	27,0	0,100	•	•	•	•	•
10,0	10,0	72,0	19,0	32,0	0,100	•	•	•	•	•
12,0	12,0	83,0	22,0	38,0	0,100	•	•	•	•	•
16,0	16,0	92,0	26,0	44,0	0,150	•	•	•	•	•
20,0	20,0	104,0	32,0	54,0	0,150	•	•	•	•	•
3,0	3,0	75,0	20,0	47,0	0,050	•	•	•	•	•
4,0	4,0	75,0	25,0	47,0	0,050	•	•	•	•	•
5,0	5,0	75,0	30,0	47,0	0,050	•	•	•	•	•
6,0	6,0	75,0	30,0	39,0	0,050	•	•	•	•	•
8,0	8,0	100,0	40,0	64,0	0,100	•	•	•	•	•
10,0	10,0	100,0	40,0	60,0	0,100	•	•	•	•	•
12,0	12,0	150,0	45,0	105,0	0,100	•	•	•	•	•
16,0	16,0	150,0	65,0	102,0	0,150	•	•	•	•	•
20,0	20,0	150,0	65,0	100,0	0,150	•	•	•	•	•

ФРЕЗЫ ПАЗОВЫЕ

ТРЕХЗУБЫЕ С ЦЕНТРАЛЬНЫМ РЕЗОМ

универсальное применение
R ≤ 1400 Н/мм²

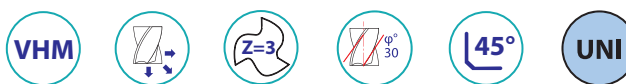

Система обозначений	
Ød1 h10	диаметр режущей части, мм
Ød2 h6	диаметр хвостовика, мм
L ₁	длина общая, мм
L ₂	длина режущей части, мм
L ₃	длина обniżения, мм
c	фаска, мм x 45°
γ	передний угол, °
Z	кол-во зубьев

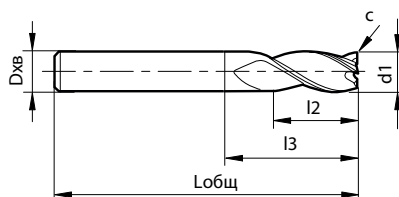

Глубина обработки	M	M	M	S	S	M	M
Угол подъема спирали, ф°	30	30	30	45	45	45	45
Материал	VHM	VHM	VHM	VHM	VHM	VHM	VHM
Покрýтие	TAIN	TAIN	TAIN	TAIN	TAIN	TAIN	TAIN
Передний угол, γ°	M	M	M	S	S	L	L
Исполнение хвостовика	HA	HB	HB	HA	HB	HA	HB
Кол-во зубьев	3	3	3	3	3	3	3
Группы обрабатываемых материалов	P	P	P	P	P	P	P
	M	M	M	M	M	M	M
	K	K	K	K	K	K	K
			N	S	S	S	S

Ød1 h10	Ød1 h6	L ₁	L ₂	L ₃	c	Артикулы							
						STM2330	STM2331	STM2333	STM2310	STM2311	STM2340	STM2341	
1,0	6,0	57,0	6,0	-	-	•	•	•					
2,0	6,0	57,0	6,0	21,0	0,025	•	•						
2,5	6,0	57,0	7,0	21,0	0,050	•	•						
3,0	6,0	57,0	7,0	21,0	0,050	•	•						
3,5	6,0	57,0	7,0	21,0	0,050	•	•						
4,0	6,0	57,0	8,0	21,0	0,050	•	•						
4,5	6,0	57,0	8,0	21,0	0,050	•	•						
5,0	6,0	57,0	10,0	21,0	0,050	•	•						
6,0	6,0	57,0	10,0	21,0	0,050	•	•						
7,0	8,0	63,0	13,0	27,0	0,100	•	•						
8,0	8,0	63,0	16,0	27,0	0,100	•	•						
8,5	10,0	72,0	16,0	32,0	0,100	•	•						
9,0	10,0	72,0	16,0	32,0	0,100	•	•						
10,0	10,0	72,0	19,0	32,0	0,100	•	•						
12,0	12,0	83,0	22,0	38,0	0,100	•	•						
14,0	14,0	83,0	22,0	38,0	0,150	•	•						
16,0	16,0	92,0	26,0	44,0	0,150	•	•						
18,0	18,0	92,0	26,0	44,0	0,150	•	•						
20,0	20,0	104,0	32,0	54,0	0,150	•	•						
3,0	6,0	50,0	4,0	14,0	0,05				•	•			
4,0	6,0	54,0	5,0	18,0	0,06				•	•			
5,0	6,0	54,0	6,0	18,0	0,08				•	•			
6,0	6,0	54,0	7,0	18,0	0,09				•	•			
7,0	8,0	58,0	8,0	22,0	0,11				•	•			
8,0	8,0	58,0	9,0	22,0	0,12				•	•			
9,0	10,0	66,0	10,0	26,0	0,14				•	•			
10,0	10,0	66,0	11,0	26,0	0,15				•	•			
12,0	12,0	73,0	12,0	28,0	0,18				•	•			
14,0	14,0	75,0	14,0	30,0	0,21				•	•			
16,0	16,0	82,0	16,0	34,0	0,19				•	•			
18,0	18,0	84,0	18,0	36,0	0,22				•	•			
20,0	20,0	92,0	20,0	42,0	0,24				•	•			
3,0	6,0	57,0	7,0	21,0	0,05						•	•	
3,5	6,0	57,0	7,0	21,0	0,05						•	•	
4,0	6,0	57,0	8,0	21,0	0,06						•	•	
4,5	6,0	57,0	8,0	21,0	0,07						•	•	
5,0	6,0	57,0	10,0	21,0	0,08						•	•	
6,0	6,0	57,0	10,0	21,0	0,09						•	•	
7,0	8,0	63,0	13,0	27,0	0,11						•	•	
8,0	8,0	63,0	16,0	27,0	0,12						•	•	
9,0	10,0	72,0	16,0	32,0	0,14						•	•	
10,0	10,0	72,0	19,0	32,0	0,15						•	•	
12,0	12,0	83,0	22,0	38,0	0,18						•	•	
14,0	14,0	83,0	22,0	38,0	0,21						•	•	
16,0	16,0	92,0	26,0	44,0	0,19						•	•	
20,0	20,0	104,0	32,0	54,0	0,24						•	•	

фрезы

ФРЕЗЫ УНИВЕРСАЛЬНЫЕ

универсальное применение
R ≤ 1400 Н/мм²



Система обозначений	
Ød1 h10	диаметр режущей части, мм
Ød2 h6	диаметр хвостовика, мм
L ₁	длина общая, мм
L ₂	длина режущей части, мм
L ₃	длина обניжения, мм
c	фаска, мм x 45°
γ	передний угол, °
Z	кол-во зубьев

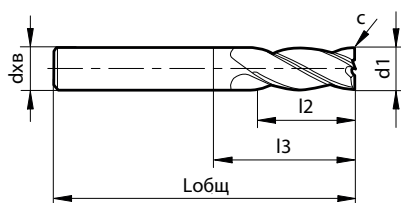

Стандарт	S	S	M	XL						
Угол подъема спирали, φ°	30	30	30	30						
Материал	VHM	VHM	VHM	VHM						
Покрyтие	TiAIN	TiAIN	TiAIN	TiAIN						
Передний угол, γ°	9	9	9	9						
Исполнение хвостовика	HA	HB	HB	HA						
Кол-во зубьев	4	4	4	4						
Группы обрабатываемых материалов	P	P	P	P						
	M	M	M	M						
	K	K	K	K						
Ød1 h10	Ød1 h6	L ₁	L ₂	L ₃	c					
DIN 6527 K							STM2410	STM2411	STM2421	STM2440
2,0	6,0	50,0	4,0	14,0	0,025	
3,0	6,0	50,0	5,0	14,0	0,05	
4,0	6,0	54,0	8,0	18,0	0,05	
5,0	6,0	54,0	9,0	18,0	0,05	
6,0	6,0	54,0	10,0	18,0	0,05	
8,0	8,0	58,0	12,0	22,0	0,10	
10,0	10,0	66,0	14,0	26,0	0,10	
12,0	12,0	73,0	16,0	28,0	0,10	
14,0	14,0	75,0	18,0	30,0	0,15	
16,0	16,0	82,0	22,0	34,0	0,15	
18,0	18,0	84,0	24,0	36,0	0,15	
20,0	20,0	92,0	26,0	42,0	0,15	
DIN 6527 L										
2,0	6,0	57,0	7,0	21,0	0,025	
3,0	6,0	57,0	8,0	21,0	0,05	
4,0	6,0	57,0	11,0	21,0	0,05	
5,0	6,0	57,0	13,0	21,0	0,05	
6,0	6,0	57,0	13,0	21,0	0,05	
7,0	8,0	63,0	16,0	27,0	0,10	
8,0	8,0	63,0	19,0	27,0	0,10	
9,0	10,0	72,0	19,0	32,0	0,10	
10,0	10,0	72,0	22,0	32,0	0,10	
12,0	12,0	83,0	26,0	38,0	0,10	
14,0	14,0	83,0	26,0	38,0	0,15	
16,0	16,0	92,0	32,0	44,0	0,15	
18,0	18,0	92,0	32,0	44,0	0,15	
20,0	20,0	104,0	38,0	54,0	0,15	
СТП										
3,0	3,0	75,0	20,0	47,0	0,05	
4,0	4,0	75,0	25,0	47,0	0,05	
5,0	5,0	75,0	30,0	47,0	0,05	
6,0	6,0	75,0	30,0	39,0	0,05	
8,0	8,0	100,0	40,0	64,0	0,10	
10,0	10,0	100,0	40,0	60,0	0,10	
12,0	12,0	150,0	45,0	105,0	0,10	
16,0	16,0	150,0	65,0	102,0	0,15	
20,0	20,0	150,0	65,0	100,0	0,15	

фрезф

ФРЕЗЫ ВЫСОКОПРОИЗВОДИТЕЛЬНЫЕ

универсальное применение,
неравный шаг зубьев



Система обозначений	
Ød1 h10	диаметр режущей части, мм
Ød2 h6	диаметр хвостовика, мм
Ød3	диаметр шейки, мм
L ₁	длина общая, мм
L ₂	длина режущей части, мм
L ₃	длина обнижения, мм
c	фаска, мм x 45°
γ	передний угол, °
Z	кол-во зубьев

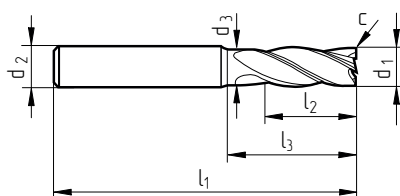

Глубина обработки	S	M	M	XL	XL	XXL									
Угол подъема спирали, φ°	35/38	35/38	35/38	35/38	35/38	35/38									
Материал	VHM	VHM	VHM	VHM	VHM	VHM									
Покрытие	TAIN	TAIN	TAIN	TAIN	TAIN	TAIN									
Передний угол, γ°	4	4	4	4	4	4									
Исполнение хвостовика	HB	HA	HB	HB	HA	HA									
Кол-во зубьев	4	4	4	4	4	4									
Группы обрабатываемых материалов	P	P	P	P	P	P									
	K	K	K	K	K	K									
							H*								
							H*								
Ød1 h10	Ød2 h6	Ød3	L ₁	L ₂	L ₃	c	Артикулы								
							STM1411	STM1420	STM1421	STM1440	STM1441	STM1450			
3,0	6,0	2,8	50,0	5,0	9,4	0,10	•								
4,0	6,0	3,8	54,0	8,0	12,9	0,10	•								
5,0	6,0	4,8	54,0	9,0	15,4	0,10	•								
6,0	6,0	5,7	54,0	10,0	18,0	0,15	•								
8,0	8,0	7,7	58,0	12,0	22,0	0,15	•								
10,0	10,0	9,5	66,0	14,0	26,0	0,20	•								
12,0	12,0	11,5	73,0	16,0	28,0	0,20	•								
14,0	14,0	13,5	75,0	18,0	30,0	0,25	•								
16,0	16,0	15,5	82,0	22,0	34,0	0,35	•								
18,0	18,0	17,5	84,0	24,0	36,0	0,40	•								
20,0	20,0	19,5	92,0	26,0	42,0	0,45	•								
3,0	6,0	2,8	57,0	8,0	12,4	0,10		•	•						
4,0	6,0	3,8	57,0	11,0	15,9	0,10		•	•						
5,0	6,0	4,8	57,0	13,0	19,4	0,10		•	•						
6,0	6,0	5,7	57,0	13,0	21,0	0,15		•	•						
8,0	8,0	7,7	63,0	19,0	27,0	0,15		•	•						
10,0	10,0	9,5	72,0	22,0	32,0	0,20		•	•						
12,0	12,0	11,5	83,0	26,0	38,0	0,20		•	•						
14,0	14,0	13,5	83,0	26,0	38,0	0,25		•	•						
16,0	16,0	15,5	92,0	32,0	44,0	0,35		•	•						
18,0	18,0	17,5	92,0	32,0	44,0	0,40		•	•						
20,0	20,0	19,5	104,0	38,0	54,0	0,45		•	•						
25,0	25,0	24,0	121,0	45,0	65,0	0,60		•	•						
6,0	6,0	5,7	65,0	18,0	28,0	0,15				•	•				
8,0	8,0	7,7	75,0	24,0	38,0	0,15				•	•				
10,0	10,0	9,5	80,0	30,0	38,0	0,20				•	•				
12,0	12,0	11,5	93,0	36,0	46,0	0,20				•	•				
16,0	16,0	15,5	108,0	48,0	58,0	0,35				•	•				
20,0	20,0	19,5	126,0	60,0	74,0	0,45				•	•				
10,0	10,0	9,5	100,0	40,0	48,0	0,20								•	
12,0	12,0	11,5	150,0	45,0	58,0	0,20								•	
14,0	14,0	13,5	150,0	45,0	58,0	0,25								•	
16,0	16,0	15,5	150,0	65,0	78,0	0,35								•	
18,0	18,0	17,5	150,0	65,0	78,0	0,40								•	
20,0	20,0	19,5	150,0	65,0	78,0	0,45								•	
25,0	25,0	24,0	150,0	75,0	92,0	0,60								•	

фрезы

ФРЕЗЫ РАДИУСНЫЕ

универсальное применение
 $R \leq 1400 \text{ Н/мм}^2$



Система обозначений	
$\varnothing d1 \text{ h}10$	диаметр режущей части, мм
$\varnothing d2 \text{ h}6$	диаметр хвостовика, мм
L_1	длина общая, мм
L_2	длина режущей части, мм
L_3	длина обнижения, мм
c	фаска, мм x 45°
γ	передний угол, °
Z	кол-во зубьев

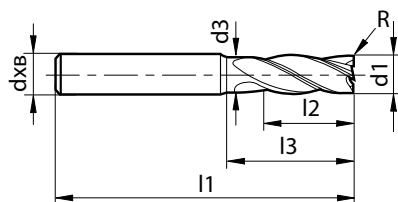

Глубина обработки	M	M	M						
Угол подъема спирали, °	35/38	35/38	35/38						
Материал	VHM	VHM	VHM						
Покрытие	TAIN	TAIN	TAIN						
Передний угол, °	5	5	5						
Исполнение хвостовика	HA	HB	HB						
Кол-во зубьев	4	4	4						
Группы обрабатываемых материалов	P	P	P						
	M	M	M						
	K	K	K						
	S	S							
$\varnothing d1 \text{ h}10$	r	$\varnothing d2 \text{ h}6$	$\varnothing d3$	L_1	L_2	L_3	Артикулы		
							STM3420 r	STM3421 r	STM 3423 r
4,0	0,25	6,0	-	57,0	11,0	-			•
	0,5		-			-	•		
	1,0		-			-	•		
5,0	0,25	6,0	-	57,0	13,0	-			•
	0,5		-			-	•		
	1,0		-			-	•		
6,0	0,5	6,0	5,7	57,0	13,0	20,0	•	•	•
	0,8						•	•	•
	1,0						•	•	•
	1,5						•	•	•
	2,0						•	•	•
8,0	0,5	8,0	7,7	63,0	19,0	26,0	•	•	•
	0,8						•	•	•
	1,0						•	•	•
	1,5						•	•	•
	2,0						•	•	•
10,0	0,5	10,0	9,5	75,0	22,0	30,0	•	•	•
	0,8						•	•	•
	1,0						•	•	•
	1,5						•	•	•
	2,0						•	•	•
12,0	0,5	12,0	11,5	83,0	26,0	36,0	•	•	•
	0,8						•	•	•
	1,0						•	•	•
	1,5						•	•	•
	2,0						•	•	•
	2,5						•	•	•
	3,0						•	•	•
	3,175						•	•	•
	4,0						•	•	•

фрез

ФРЕЗЫ РАДИУСНЫЕ

универсальное применение
 $R \leq 1400 \text{ Н/мм}^2$



Система обозначений	
$\varnothing d1 \text{ h}10$	диаметр режущей части, мм
$\varnothing d2 \text{ h}6$	диаметр хвостовика, мм
L_1	длина общая, мм
L_2	длина режущей части, мм
L_3	длина обniżения, мм
c	фаска, мм x 45°
γ	передний угол, °
Z	кол-во зубьев

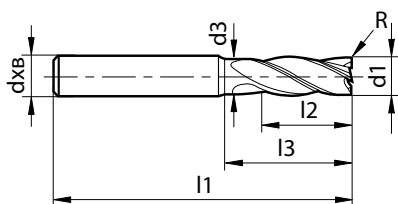

Глубина обработки	M	M	M						
Угол подъема спирали, °	35/38	35/38	35/38						
Материал	VHM	VHM	VHM						
	TAIN	TAIN	TAIN						
Передний угол, °	5	5	5						
Исполнение хвостовика	HA	HB	HB						
Кол-во зубьев	4	4	4						
Группы обрабатываемых материалов	P	P	P						
	M	M	M						
	K	K	K						
	S	S	S						
$\varnothing d1 \text{ h}10$	r	$\varnothing d2 \text{ h}6$	$\varnothing d3$	L_1	L_2	L_3	Артикулы		
							STM3420 r	STM3421 r	STM 3423 r
14,0	1,0	14,0	-	83,0	26,0	-			•
	2,0		-						•
16,0	0,5	16,0	15,5	83,0	26,0	36,0	•	•	
	0,8							•	
	1,0		-	92,0	32,0	-			•
	1,5		15,5	83,0	26,0	36,0	•	•	
			-	92,0	32,0	-			•
	2,0		15,5	83,0	26,0	36,0	•	•	
			-	92,0	32,0	-			•
			15,5	83,0	26,0	36,0	•	•	
			-	92,0	32,0	-			•
	3,0								•
3,175	15,5	83,0	26,0	36,0	•	•			
4,0							•		
18,0	1,5	18,0	-	92,0	32,0	-			•
	2,0		-						•
20,0	0,5	20,0	19,5	104,0	38,0	52,0	•	•	•
	1,0						•	•	•
	1,5						•	•	•
	2,0						•	•	•
	2,5						•	•	•
	3,0						•	•	•
	3,175						•	•	•
	4,0						•	•	•
	5,0						•	•	•
	25,0						1,5	25,0	24,0
2,0		•	•						
2,5		•	•						
3,0		•	•						
3,175		•	•						
4,0		•	•						
5,0	•	•							

фрезы

ФРЕЗЫ РАДИУСНЫЕ

для нержавеющей сталей >1000 Н/мм²

для титановых сплавов



Система обозначений	
Ød1 h10	диаметр режущей части, мм
Ød2 h6	диаметр хвостовика, мм
Ød3	диаметр шейки, мм
L ₁	длина общая, мм
L ₂	длина режущей части, мм
L ₃	длина обнижения, мм
c	фаска, мм x 45°
γ	передний угол, °
Z	кол-во зубьев

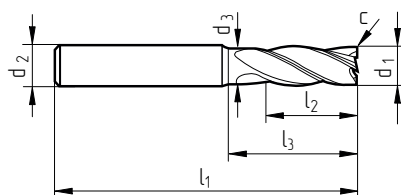

Глубина обработки		M	M						
Угол подъема спирали, φ°		36/39	36/39						
Материал		VHM	VHM						
Покрытие									
Передний угол, γ°		4	4						
Исполнение хвостовика		HA	HB						
Кол-во зубьев		4	4						
Группы обрабатываемых материалов		P	P						
		M	M						
		S	S						
Ød1 h10	Ød2 h6	Ød3	L ₁	L ₂	L ₃	c	STM7420	STM7421	
3,0	6,0	2,8	57,0	8,0	15,0	0,10	•	•	
3,5		3,3		10,0			•	•	
4,0		3,8		11,0			•	•	
4,5		4,3		11,0			18,0	•	•
5,0		4,8		13,0			•	•	
5,5		5,3		13,0			19,4	•	•
6,0	5,8	13,0	20,0	•	•				
6,5	8,0	6,2	57,0	16,0	24,5	0,20	•	•	
7,0		6,7	63,0	16,0	25,0		•	•	
7,5		7,2	19,0	25,5	•		•		
8,0		7,8	19,0	26,0	•		•		
8,5	10,0	8,2	72,0	19,0	30,0	0,20	•	•	
9,0		8,7		19,0			•	•	
9,5		9,2		22,0			•	•	
10,0	12,0	9,5	83,0	22,0	35,0	0,20	•	•	
11,0		10,5		26,0			36,0	•	•
12,0	11,8	26,0	36,0	•	•				
14,0	14,0	13,5	92,0	26,0	36,0	0,40	•	•	
16,0	16,0	15,5		32,0	42,0	0,50	•	•	
18,0	18,0	17,5		32,0	42,0	0,60	•	•	
20,0	20,0	19,5		104,0	38,0	52,0	0,60	•	•
25,0	25,0	24,0	121,0	45,0	63,0	0,75	•	•	

фрезф

ФРЕЗЫ РАДИУСНЫЕ

для нержавеющей сталей >1000 Н/мм²

для титановых сплавов

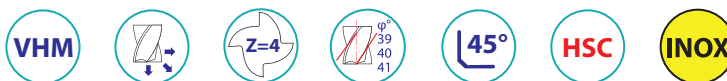

Система обозначений	
Ød1 h10	диаметр режущей части, мм
Ød2 h6	диаметр хвостовика, мм
Ød3	диаметр шейки, мм
L ₁	длина общая, мм
L ₂	длина режущей части, мм
L ₃	длина обнижения, мм
c	фаска, мм x 45°
γ	передний угол, °
Z	кол-во зубьев

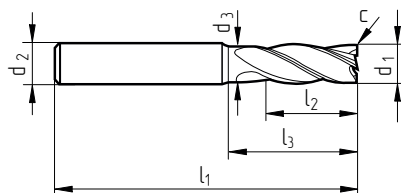

Глубина обработки		M						
Угол подъема спирали, φ°		36/38/37						
Материал		VHM						
Покрытие		TiAlSiN						
Передний угол, γ°		4						
Исполнение хвостовика		HA HB						
Кол-во зубьев		4						
Группы обрабатываемых материалов		P	P					
		M	M					
		K	K					
		S	S					
Ød1 h10	Ød2 h6	Ød3	L ₁	L ₂	L ₃	c	STM3430	STM3431
4,0	6,0	3,8	57,0	11,0	15,9	0,04	•	•
5,0		4,8		13,0	19,4	0,05	•	•
5,7		5,5		13,0	20,4	0,06	•	•
6,0	8,0	5,7	63,0	13,0	21,0	0,06	•	•
7,7		7,4		19,0	26,9	0,08	•	•
8,0	10,0	7,7	72,0	19,0	27,0	0,08	•	•
9,7		9,4		22,0	31,4	0,10	•	•
10,0	12,0	9,5	83,0	22,0	32,0	0,10	•	•
11,7		11,2		26,0	36,4	0,12	•	•
12,0		11,5		26,0	38,0	0,12	•	•
13,7	14,0	13,2	92,0	26,0	31,0	0,14	•	•
14,0	14,0	13,5		26,0	38,0	0,14	•	•
15,6	16,0	15,1	104,0	32,0	36,0	0,16	•	•
16,0	16,0	15,5		32,0	44,0	0,16	•	•
19,5	20,0	19,0		38,0	54,0	0,20	•	•
20,0		19,5		38,0	54,0	0,20	•	•

фрезы

ФРЕЗЫ РАДИУСНЫЕ

универсальное применение
 $R \leq 1400 \text{ Н/мм}^2$

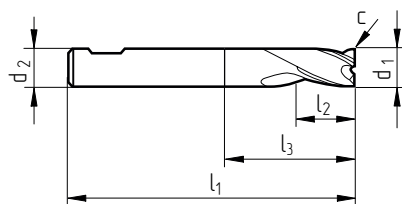
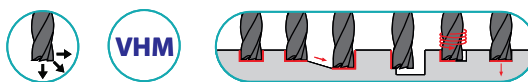

Система обозначений	
$\varnothing d1 \text{ e8}$	диаметр режущей части, мм
$\varnothing d2 \text{ h6}$	диаметр хвостовика, мм
L_1	длина общая, мм
L_2	длина режущей части, мм
L_3	длина обניжения, мм
c	фаска, мм x 45°
γ	передний угол, °
Z	кол-во зубьев



Глубина обработки	XS					
Угол подъема спирали, φ°	30					
Материал	VHM					
Покрывтие	TAIN					
Передний угол, γ°	12					
Исполнение хвостовика	HB					
Кол-во зубьев	3					
Группы обрабатываемых материалов	P					
	M					
	K*					
	S*					
$\varnothing d1 \text{ e8}$	$\varnothing d1 \text{ h6}$	L_1	L_2	L_3	c	Артикулы
STM3301						
0,3	3,0	38,0	1,0	13,0	-	•
0,4	3,0	38,0	1,0	13,0	-	•
0,5	3,0	38,0	1,5	13,0	0,025	•
0,6	3,0	38,0	1,5	13,0	0,025	•
0,8	3,0	38,0	2,0	12,0	0,025	•
1,0	3,0	38,0	2,0	12,0	0,025	•
1,2	3,0	38,0	2,0	12,0	0,025	•
1,5	3,0	38,0	2,0	13,0	0,025	•
1,8	3,0	38,0	2,0	13,0	0,025	•
2,0	6,0	38,0	4,0	14,0	0,025	•
2,5	6,0	38,0	5,0	14,0	0,050	•
3,0	6,0	38,0	5,0	14,0	0,050	•
3,5	6,0	38,0	6,0	14,0	0,050	•
4,0	6,0	38,0	7,0	14,0	0,050	•
4,5	6,0	38,0	8,0	14,0	0,050	•
5,0	6,0	38,0	8,0	14,0	0,050	•
5,5	6,0	38,0	8,0	14,0	0,050	•
5,8	6,0	38,0	8,0	14,0	0,050	•
6,0	6,0	38,0	8,0	14,0	0,050	•
6,8	8,0	42,0	10,0	18,0	0,100	•
7,0	8,0	42,0	10,0	18,0	0,100	•
7,8	8,0	42,0	10,0	18,0	0,100	•
8,0	8,0	43,0	11,0	19,0	0,100	•
8,7	10,0	48,0	11,0	21,0	0,100	•
9,0	10,0	48,0	11,0	21,0	0,100	•
9,7	10,0	48,0	11,0	21,0	0,100	•
10,0	10,0	50,0	13,0	23,0	0,100	•
12,0	12,0	55,0	15,0	25,0	0,100	•
14,0	14,0	58,0	15,0	28,0	0,150	•
16,0	16,0	62,0	18,0	29,0	0,150	•
18,0	18,0	70,0	20,0	37,0	0,150	•
20,0	20,0	75,0	22,0	41,0	0,150	•

						S
						45
						VHM
						TAIN
						12
						HB
						3
						P
						M
						K*
						S*
$\varnothing d1 \text{ e8}$	$\varnothing d1 \text{ h6}$	L_1	L_2	L_3	c	Артикулы
STM2301						
1,0	3,0	38,0	2,0	12,0	0,025	•
1,2	3,0	38,0	2,0	12,0	0,025	•
1,5	3,0	38,0	3,0	13,0	0,025	•
1,8	3,0	38,0	3,0	13,0	0,025	•
2,0	6,0	45,0	4,0	15,0	0,025	•
2,5	6,0	45,0	5,0	15,0	0,050	•
3,0	6,0	45,0	6,0	15,0	0,050	•
3,5	6,0	45,0	6,0	15,0	0,050	•
4,0	6,0	45,0	7,0	15,0	0,050	•
4,5	6,0	45,0	8,0	15,0	0,050	•
5,0	6,0	45,0	8,0	15,0	0,050	•
5,5	6,0	45,0	8,0	15,0	0,050	•
5,8	6,0	45,0	10,0	15,0	0,050	•
6,0	6,0	45,0	10,0	15,0	0,050	•
6,8	8,0	55,0	10,0	19,0	0,100	•
7,0	8,0	55,0	12,0	19,0	0,100	•
7,8	8,0	55,0	12,0	19,0	0,100	•
8,0	8,0	55,0	13,0	19,0	0,100	•
8,7	10,0	55,0	14,0	25,0	0,100	•
9,0	10,0	55,0	14,0	25,0	0,100	•
9,7	10,0	55,0	16,0	25,0	0,100	•
10,0	10,0	55,0	16,0	25,0	0,100	•

фрез

ФРЕЗЫ СФЕРИЧЕСКИЕ

2-Х И 4-ЗУБЫЕ DIN 6527L С ЦЕНТРАЛЬНЫМ РЕЗОМ

универсальное применение
 $R \leq 1200 \text{ Н/мм}^2$

Система обозначений	
$\varnothing d1 \text{ h10}$	диаметр режущей части, мм
$\varnothing d2 \text{ h6}$	диаметр хвостовика, мм
L_1	длина общая, мм
L_2	длина режущей части, мм
L_3	длина обניжения, мм
r	радиус скругления, мм
γ	передний угол, °
Z	кол-во зубьев

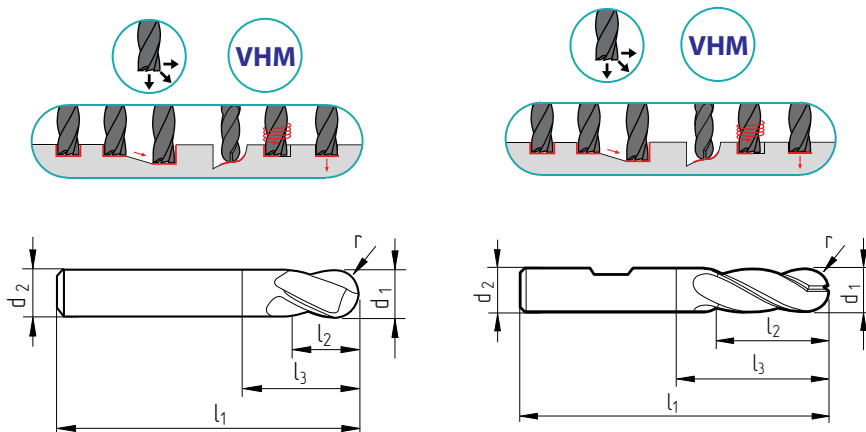

Глубина обработки	M	M	M					
Угол подъема спирали, °	30	30	30					
Материал	VHM	VHM	VHM					
Передний угол, °	TiAlN	TiAlN	TiAlN					
Исполнение хвостовика	9	9	9					
Кол-во зубьев	HA	HB	HB					
Группы обрабатываемых материалов	2	2	4					
	P	P	P					
	M	M	M					
	K	K	K					
	S	S	S					
	H	H	H					
$\varnothing d1 \text{ h10}$	$\varnothing d1 \text{ h6}$	L_1	L_2	L_3	r	Артикулы		
						STM8220	STM8221	STM8421
0,5	3,0	38,0	1,0	10,0	0,25	•	•	•
1,0	3,0	38,0	2,0	10,0	0,50	•	•	•
1,5	3,0	38,0	3,0	10,0	0,75	•	•	•
2,0	6,0	57,0	6,0	21,0	1,00	•	•	•
3,0	6,0	57,0	7,0	21,0	1,50	•	•	•
4,0	6,0	57,0	8,0	21,0	2,00	•	•	•
5,0	6,0	57,0	10,0	21,0	2,50	•	•	•
6,0	6,0	57,0	10,0	21,0	3,00	•	•	•
8,0	8,0	63,0	16,0	27,0	4,00	•	•	•
10,0	10,0	72,0	19,0	32,0	5,00	•	•	•
12,0	12,0	83,0	22,0	38,0	6,00	•	•	•
20,0	20,0	104,0	32,0	54,0	10,00	•	•	•
3,0	6,0	57,0	8,0	21,0	1,5	•	•	•
4,0	6,0	57,0	11,0	21,0	2,0	•	•	•
5,0	6,0	57,0	13,0	21,0	2,5	•	•	•
6,0	6,0	57,0	13,0	21,0	3,0	•	•	•
8,0	8,0	63,0	19,0	27,0	4,0	•	•	•
10,0	10,0	72,0	22,0	32,0	5,0	•	•	•
12,0	12,0	83,0	26,0	38,0	6,0	•	•	•
20,0	20,0	104,0	38,0	54,0	10,0	•	•	•

фрезы



РЕЖИМЫ РЕЗАНИЯ. ВЫСОКОПРОИЗВОДИТЕЛЬНОЕ ФРЕЗЕРОВАНИЕ

Применение		коэфф. Vc	коэфф. fz	Подача на ширину, ae			Подача на глубину, ap						
Обработка пазов		1.0	1.0 (0,7 при ap = 2xd)	1xd			от 0.5 до 1xd						
Обдирка		1.0	1.0 (0,7 при ap = 2xd)	от 0,4 до 0,9xd			от 0.5 до 1xd						
Чистовая обр.		1,0	1.0	от 0,01 до 0,1xd			от 1 до 2xd						
НРС обработка		1.3	1.5	от 0,15 до 0,4xd			от 1 до 2xd						
HSC обработка		1.5	2.0	от 0,05 до 0,15xd			от 1 до 2xd						
Материал по ГОСТ, DIN, ISO		Твердость, Н/мм ²	Оптимальная геометрия	Вид обработки	Скорость резания, Vc (м/мин)	Подача на зуб от Ø фрезы, fz (мм/зуб)							
						3	6	8	10	12	16	20	25
P	Конструкционные, Автоматные, Улучшаемые, Цементируемые стали	<850	Нержавеющие ст.	Обработка пазов	180	0,018	0,035	0,045	0,06	0,07	0,09	0,1	0,15
			Нержавеющие ст.	Обдирка	200	0,02	0,04	0,055	0,07	0,085	0,1	0,12	0,17
			Получистовая обр.	Чистовая	280	0,016	0,03	0,04	0,055	0,065	0,08	0,095	0,14
	Автоматные, Цементируемые, Азотируемые стали	850-1200	Универсальное пр.	Обработка пазов	160	0,018	0,035	0,045	0,06	0,07	0,09	0,1	0,15
			Универсальное пр.	Обдирка	180	0,02	0,04	0,055	0,07	0,085	0,1	0,12	0,17
			Получистовая обр.	Чистовая	220	0,016	0,03	0,04	0,055	0,065	0,08	0,095	0,14
	Легированные Улучшаемые, Инструментальные, Быстрорежущие стали	850-1400	Универсальное пр.	Обработка пазов	135	0,016	0,03	0,04	0,055	0,065	0,08	0,095	0,14
			Универсальное пр.	Обдирка	160	0,02	0,04	0,05	0,065	0,08	0,095	0,11	0,16
			Получистовая обр.	Чистовая обр.	200	0,015	0,03	0,04	0,05	0,06	0,07	0,09	0,13
H	Стали термообработанные (Инструментальные, Улучшаемые, Рессорно-Пружинные, Быстрорежущие, Цементируемые)	<54 HRC	Универсальное пр.	Обработка пазов	70	0,012	0,025	0,03	0,04	0,045	0,06	0,07	0,1
			Универсальное пр.	Обдирка	110	0,015	0,025	0,035	0,045	0,05	0,065	0,08	0,12
			Получистовая обр.	Чистовая	150	0,015	0,03	0,04	0,05	0,06	0,07	0,09	0,13
		54-60 HRC		Обработка пазов									
			Закаленные ст.	Обдирка									
Закаленные ст.	Чистовая	110	0,01	0,015	0,025	0,035	0,042	0,05	0,08	0,09			
M	Ферритные, Аустенитные, Аустенитно-ферритные, Аустенитно-ферритные жаропрочные	<750	Нержавеющие ст.	Обработка пазов	120	0,015	0,03	0,04	0,05	0,06	0,07	0,09	0,13
			Нержавеющие ст.	Обдирка	140	0,018	0,035	0,045	0,06	0,07	0,09	0,1	0,15
			Получистовая обр.	Чистовая	180	0,016	0,03	0,04	0,055	0,065	0,08	0,095	0,14
		750-850	Нержавеющие ст.	Обработка пазов	80	0,015	0,025	0,035	0,045	0,05	0,065	0,08	0,12
			Нержавеющие ст.	Обдирка	120	0,016	0,03	0,04	0,055	0,065	0,08	0,095	0,14
			Получистовая обр.	Чистовая	140	0,015	0,03	0,04	0,05	0,06	0,07	0,09	0,13
		>850	Нержавеющие ст.	Обработка пазов	70	0,012	0,025	0,03	0,04	0,045	0,06	0,07	0,1
			Нержавеющие ст.	Обдирка	100	0,015	0,025	0,035	0,045	0,05	0,065	0,08	0,12
			Получистовая обр.	Чистовая	120	0,015	0,025	0,035	0,045	0,05	0,065	0,08	0,12
S	Чистый Никель, Сплавы на основе Ni (НП2, ХН63МБ ХН73МВТЮ)	<1300	Универсальное пр.	Обработка пазов	30	0,01	0,015	0,02	0,025	0,03	0,04	0,05	0,06
			Универсальное пр.	Обдирка	35	0,01	0,02	0,03	0,035	0,04	0,055	0,065	0,08
			Получистовая обр.	Чистовая обр.	45	0,015	0,025	0,035	0,045	0,05	0,065	0,08	0,12
	Чистый Титан, Титановые сплавы (BT1, BT6, BT22)	<1300	Универсальное пр.	Обработка пазов	60	0,015	0,025	0,035	0,045	0,05	0,065	0,08	0,12
			Универсальное пр.	Обдирка	90	0,016	0,03	0,04	0,055	0,065	0,08	0,095	0,14
			Получистовая обр.	Чистовая обр.	130	0,016	0,03	0,04	0,055	0,065	0,08	0,095	0,14
K	Чугун литейный, Серый чугун, Ковкий чугун, С шаровидным графитом (СЧ10, ВЧ40, КЧ35, ЧВГ30)	<240 HB	Нержавеющие ст.	Обработка пазов	160	0,02	0,04	0,05	0,065	0,08	0,095	0,11	0,16
			Нержавеющие ст.	Обдирка	180	0,02	0,04	0,055	0,07	0,085	0,1	0,12	0,17
			Получистовая обр.	Чистовая обр.	220	0,018	0,035	0,045	0,06	0,07	0,09	0,1	0,15
		>240 HB	Универсальное пр.	Обработка пазов	140	0,016	0,03	0,04	0,055	0,065	0,08	0,095	0,14
			Универсальное пр.	Обдирка	160	0,02	0,04	0,05	0,065	0,08	0,095	0,11	0,16
			Получистовая обр.	Чистовая обр.	200	0,018	0,035	0,045	0,06	0,07	0,09	0,1	0,15
N	Алюминий и сплавы на основе алюминия	Si<3%	Мягкие металлы	Обработка пазов	500	0,02	0,04	0,05	0,065	0,08	0,095	0,11	0,16
			Мягкие металлы	Обдирка	600	0,02	0,04	0,055	0,07	0,085	0,1	0,12	0,17
			Мягкие металлы	Чистовая обр.	1000	0,018	0,035	0,045	0,06	0,07	0,09	0,1	0,15
	Сплавы алюминиевые литейные	Si>3%	Мягкие металлы	Обработка пазов	230	0,016	0,03	0,04	0,055	0,065	0,08	0,095	0,14
			Мягкие металлы	Обдирка	280	0,02	0,04	0,05	0,065	0,08	0,095	0,11	0,16
			Мягкие металлы	Чистовая обр.	350	0,018	0,035	0,045	0,06	0,07	0,09	0,1	0,15
	Магниеые сплавы	-	Мягкие металлы	Обработка пазов	180	0,016	0,03	0,04	0,055	0,065	0,08	0,095	0,14
			Мягкие металлы	Обдирка	220	0,02	0,04	0,05	0,065	0,08	0,095	0,11	0,16
			Мягкие металлы	Чистовая обр.	280	0,018	0,035	0,045	0,06	0,07	0,09	0,1	0,15
	Неметаллы, Медь, Латунь, Бронза	<750	Мягкие металлы	Обработка пазов	250	0,015	0,025	0,035	0,045	0,05	0,065	0,08	0,12
			Мягкие металлы	Обдирка	300	0,016	0,03	0,04	0,055	0,065	0,08	0,095	0,14
			Получистовая обр.	Чистовая обр.	400	0,016	0,03	0,04	0,055	0,065	0,08	0,095	0,14



РЕЖИМЫ РЕЗАНИЯ. УНИВЕРСАЛЬНОЕ ФРЕЗЕРОВАНИЕ Z=2/4

Применение		коэфф. Vc	коэфф. fz			Подача на ширину, ae			Подача на глубину, ap	
Обработка пазов		1.0	1.0 (0,7 при ap = 2xd)			1xd			от 0.5 до 1xd	
Обдирка		1,0	1.0 (0,7 при ap = 2xd)			от 0,4 до 0,9xd			от 0.5 до 1xd	
Чистовая обр.		1,0	1.0			от 0,01 до 0,1xd			от 1 до 2xd	
HPC обработка		1.3	1.5			от 0,15 до 0,4xd			от 1 до 2xd	
HSC обработка		1.5	2.0			от 0,05 до 0,15xd			от 1 до 2xd	
Оптимальная геометрия	Вид обработки	Скорость резания, Vc (м/мин)	Подача на зуб от Ø фрезы, fz (мм/зуб)							
			3	6	8	10	12	16	20	25
2-х зубые	Обработка пазов	125	0,013	0,025	0,032	0,042	0,049	0,063	0,070	0,105
2-/4-х зубые	Обдирка	140	0,014	0,028	0,039	0,049	0,060	0,070	0,084	0,119
4-х зубые	Чистовая обр.	190	0,011	0,021	0,028	0,039	0,046	0,056	0,067	0,098
2-х зубые	Обработка пазов	110	0,013	0,025	0,032	0,042	0,049	0,063	0,070	0,105
2-/4-х зубые	Обдирка	130	0,014	0,028	0,039	0,049	0,060	0,070	0,084	0,119
4-х зубые	Чистовая обр.	150	0,011	0,021	0,028	0,039	0,046	0,056	0,067	0,098
2-х зубые	Обработка пазов	95	0,011	0,021	0,028	0,039	0,046	0,056	0,067	0,098
2-/4-х зубые	Обдирка	115	0,014	0,028	0,035	0,046	0,056	0,067	0,077	0,112
4-х зубые	Чистовая обр.	140	0,011	0,021	0,028	0,035	0,042	0,049	0,063	0,091
2-х зубые	Обработка пазов	50	0,007	0,015	0,018	0,024	0,027	0,036	0,042	0,060
2-/4-х зубые	Обдирка	75	0,009	0,015	0,021	0,027	0,030	0,039	0,048	0,072
4-х зубые	Чистовая обр.	105	0,009	0,018	0,024	0,030	0,036	0,042	0,054	0,078
2-х зубые	Обработка пазов									
2-/4-х зубые	Обдирка									
4-х зубые	Чистовая обр.									
2-х зубые	Обработка пазов	85	0,009	0,018	0,024	0,030	0,036	0,042	0,054	0,078
2-/4-х зубые	Обдирка	100	0,011	0,021	0,027	0,036	0,042	0,054	0,060	0,090
4-х зубые	Чистовая обр.	125	0,010	0,018	0,024	0,033	0,039	0,048	0,057	0,084
2-х зубые	Обработка пазов	55	0,009	0,015	0,021	0,027	0,030	0,039	0,048	0,072
2-/4-х зубые	Обдирка	85	0,010	0,018	0,024	0,033	0,039	0,048	0,057	0,084
4-х зубые	Чистовая обр.	100	0,009	0,018	0,024	0,030	0,036	0,042	0,054	0,078
2-х зубые	Обработка пазов	50	0,007	0,015	0,018	0,024	0,027	0,036	0,042	0,060
2-/4-х зубые	Обдирка	70	0,009	0,015	0,021	0,027	0,030	0,039	0,048	0,072
4-х зубые	Чистовая обр.	85	0,009	0,015	0,021	0,027	0,030	0,039	0,048	0,072
2-х зубые	Обработка пазов	20	0,006	0,009	0,012	0,015	0,018	0,024	0,030	0,036
2-/4-х зубые	Обдирка	25	0,006	0,012	0,018	0,021	0,024	0,033	0,039	0,048
4-х зубые	Чистовая обр.	30	0,009	0,015	0,021	0,027	0,030	0,039	0,048	0,072
2-х зубые	Обработка пазов	40	0,009	0,015	0,021	0,027	0,030	0,039	0,048	0,072
2-/4-х зубые	Обдирка	60	0,010	0,018	0,024	0,033	0,039	0,048	0,057	0,084
4-х зубые	Чистовая обр.	90	0,010	0,018	0,024	0,033	0,039	0,048	0,057	0,084
2-х зубые	Обработка пазов	115	0,012	0,024	0,030	0,039	0,048	0,057	0,066	0,096
2-/4-х зубые	Обдирка	125	0,012	0,024	0,033	0,042	0,051	0,060	0,072	0,102
4-х зубые	Чистовая обр.	155	0,011	0,021	0,027	0,036	0,042	0,054	0,060	0,090
2-х зубые	Обработка пазов	100	0,010	0,018	0,024	0,033	0,039	0,048	0,057	0,084
2-/4-х зубые	Обдирка	115	0,012	0,024	0,030	0,039	0,048	0,057	0,066	0,096
4-х зубые	Чистовая обр.	140	0,011	0,021	0,027	0,036	0,042	0,054	0,060	0,090
2-х зубые	Обработка пазов	350	0,014	0,028	0,035	0,046	0,056	0,067	0,077	0,112
2-/4-х зубые	Обдирка	420	0,014	0,028	0,039	0,049	0,060	0,070	0,084	0,119
4-х зубые	Чистовая обр.	700	0,013	0,025	0,032	0,042	0,049	0,063	0,070	0,105
2-х зубые	Обработка пазов	160	0,011	0,021	0,028	0,039	0,046	0,056	0,067	0,098
2-/4-х зубые	Обдирка	200	0,014	0,028	0,035	0,046	0,056	0,067	0,077	0,112
4-х зубые	Чистовая обр.	245	0,013	0,025	0,032	0,042	0,049	0,063	0,070	0,105
2-х зубые	Обработка пазов	125	0,011	0,021	0,028	0,039	0,046	0,056	0,067	0,098
2-/4-х зубые	Обдирка	150	0,014	0,028	0,035	0,046	0,056	0,067	0,077	0,112
4-х зубые	Чистовая обр.	200	0,013	0,025	0,032	0,042	0,049	0,063	0,070	0,105
2-х зубые	Обработка пазов	175	0,011	0,018	0,025	0,032	0,035	0,046	0,056	0,084
2-/4-х зубые	Обдирка	210	0,011	0,021	0,028	0,039	0,046	0,056	0,067	0,098
4-х зубые	Чистовая обр.	280	0,011	0,021	0,028	0,039	0,046	0,056	0,067	0,098

фрезы

РАЗВЕРТКИ

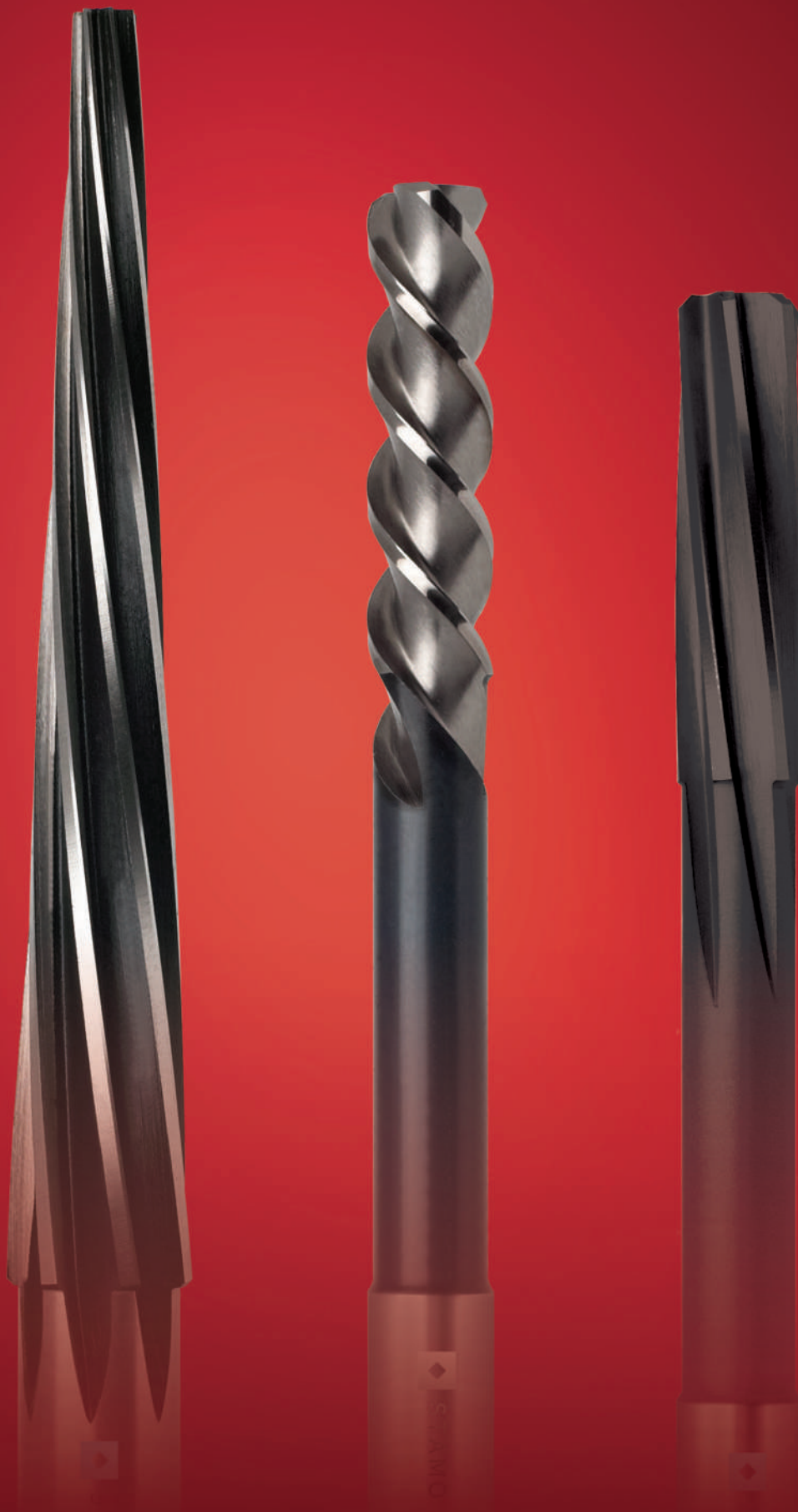

РАЗВЕРТКИ: ТЕХНИЧЕСКАЯ ИНФОРМАЦИЯ	стр 161
РАЗВЕРТКИ VHM ДЛЯ СТАНКОВ ЧПУ	стр 166
РАЗВЕРТКИ МАШИННЫЕ VHM	стр 172
РАЗВЕРТКИ VHM	стр 174
ВЫСОКОПРОИЗВОДИТЕЛЬНЫЕ РАЗВЕРТКИ VHM	стр 177
МАШИННЫЕ РАЗВЕРТКИ VHM ХВОСТОВИК С КОНУСОМ МОРЗЕ. УНИВЕРСАЛЬНОЕ ПРИМЕНЕНИЕ	стр 182
АВТОМАТНЫЕ РАЗВЕРТКИ VHM	стр 185
РУЧНЫЕ РАЗВЕРТКИ HSS	стр 186
МАШИННЫЕ РАЗВЕРТКИ HSSE ДЛЯ СТАНКОВ С ЧПУ	стр 188
МАШИННЫЕ РАЗВЕРТКИ HSSE	стр 193
АВТОМАТНЫЕ РАЗВЕРТКИ HSSE	стр 199
МАШИННЫЕ РАЗВЕРТКИ HSSE СПИРАЛЬ 45°.	стр 200
МАШИННЫЕ РАЗВЕРТКИ HSSE ХВОСТОВИК С КОНУСОМ МОРЗЕ.	стр 201
РУЧНЫЕ КОНИЧЕСКИЕ РАЗВЕРТКИ HSSE	стр 205
МАШИННЫЕ КОНИЧЕСКИЕ РАЗВЕРТКИ HSSE	стр 207
РУЧНЫЕ РАЗВЕРТКИ VHM	стр 209
МАШИННЫЕ НАСАДНЫЕ РАЗВЕРТКИ HSSE, VHM	стр 210
РАЗВЕРТКИ. РЕЖИМЫ РЕЗАНИЯ	стр 215

Развертка – это режущий инструмент, предназначен для окончательной обработки отверстий после сверления, зенкерования или растачивания.

С помощью развертки достигается точность до 6-9 квалитета и шероховатость поверхности до $Ra=0,32 \dots 1,25$ мкм.

Не следует путать **зенкер** с **разверткой**, зенкер имеет меньшее число режущих кромок, другую заточку и является полуставным инструментом для получения отверстий невысокой точности.

Развертка имеет большее число режущих кромок и при выполнении работы путем вращения и одновременно поступательном движении вдоль оси отверстия снимает малый припуск с высокой точностью, тем самым обеспечивает высококачественную обработку отверстий.

ОСНОВНЫЕ КОНСТРУКТИВНЫЕ ЭЛЕМЕНТЫ РАЗВЕРТКИ

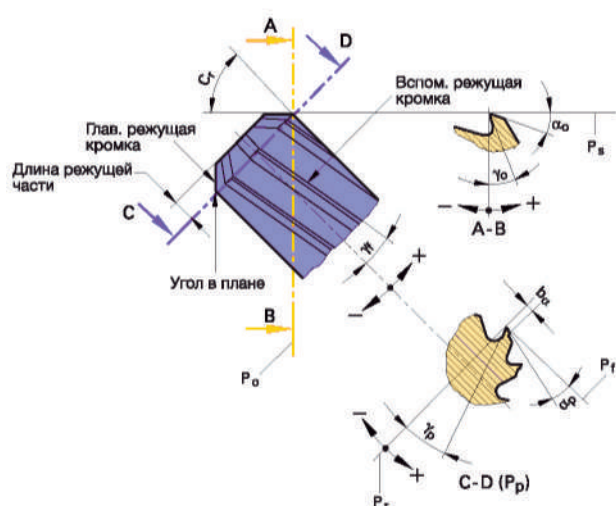

Основными конструктивными элементами развертки являются режущая и калибрующая части, число зубьев, направление зубьев, шаг зубьев, профиль канавки, углы резания, зажимная часть.

- α_0 - задний угол
- α_p - задний угол вспомогательной режущей кромки
- b_a - ширина ленточки в радиальной плоскости
- γ_0 - передний угол
- γ_f - угол подъема винтовой канавки
- γ_p - передний угол вспомогательной режущей кромки
- χ_r - угол в плане
- P_0 - плоскость перпендикулярная режущей кромке
- P_f - рабочая плоскость инструмента
- P_p - задняя плоскость инструмента
- P_r - базовая плоскость инструмента
- P_s - плоскость режущей кромки инструмента

ТИПЫ ОТВЕРСТИЙ



Сквозное отверстие

при наружном охлаждении предпочтительней использовать спиральный инструмент, так как спираль выводит стружку в направлении обработки.



Глухое отверстие

рекомендуется обрабатывать инструментом с прямыми канавками, можно так же обрабатывать спиральным инструментом, если имеется достаточно места в основании отверстия.



Прерывистое отверстие

Рекомендуется использовать спиральный инструмент, так как, такая форма лезвия в отличие от инструмента с прямыми канавками, меньше склонна к зацеплению в поперечных отверстиях.

Для получения наилучших результатов при развертывании очень важно правильно подобрать и заставить развертку работать. Режимы резания, биение в патроне, припуск отверстия, закрепленная деталь, применение СОЖ, стружка в канавках, всё это влияет на работу развертки и получения желаемого результата.

Режимы резания при развертывании зависят от обрабатываемого материала, припуска под обработку, требуемого качества отверстия, СОЖ и других факторов.

КЛАССИФИКАЦИЯ РАЗВЕРТОК

По типу обрабатываемого отверстия	цилиндрические
	конические
	ступенчатые

По способу зажима инструмента	ручные с квадратным хвостовиком под вороток
	машинные с цилиндрическим хвостовиком
	машинные с Конус Морзе, машинные насадные

По точности	с указанием квалитета
	с указанием качества (для конических)
	регулируемые

Другие свойства	прямые и спиральные стружкоотводные канавки
	количество режущих кромок
	материал инструмента

Величина необходимого припуска для развертывания, зависит от качества отверстия и обрабатываемого материала. Основные рекомендации по припуску приведены в таблицах

ДИАМЕТР РАЗВЕРТЫВАЕМОГО ОТВЕРСТИЯ (мм)	ПОСЛЕ СВЕРЛЕНИЯ	ПОСЛЕ ЗЕНКЕРОВАНИЯ
Менее 4	0,1	0,1
От 4 до 11	0,2	0,15
От 11 до 39	0,3	0,2
От 39 до 50	0,4	0,3

ГРАНИЦЫ ПОЛЕЙ ДОПУСКОВ

1. На диаметр стандартной развертки

Диаметр измеряется по ленточке сразу же за направляющей или заборной частью. Допуск назначен для обработки отверстия с допуском на диаметр H7.

ДОПУСК РАЗВЕРТКИ			
ДИАМЕТР (мм)		ГРАНИЦА ПОЛЯ ДОПУСКА (мм)	
от	до (включительно)	верхняя +	нижняя +
-	3	0,008	0,004
3	6	0,010	0,005
6	10	0,012	0,006
10	18	0,015	0,008
18	30	0,017	0,009
30	50	0,021	0,012
50	80	0,025	0,014

2. Для отверстия с допуском H7

Точные отверстия, в большинстве случаев, выполняются с допуском H7, для отверстий с другими допусками см. схему расчета и таблицу .

ДОПУСК РАЗВЕРТКИ			
ДИАМЕТР (мм)		ГРАНИЦА ПОЛЯ ДОПУСКА (мм)	
от	до (включительно)	верхняя +	нижняя +
-	3	0,010	0
3	6	0,012	0
6	10	0,015	0
10	18	0,017	0
18	30	0,021	0
30	50	0,025	0
50	80	0,030	0

3. Для определения размеров развертки для обработки отверстия с определенным допуском, можно использовать следующие рекомендации

ПОЛЕ ДОПУСКА	ПОЛЕ ДОПУСКА НА ДИАМЕТР							
	от 1 до 3	от 3 до 6	от 6 до 10	от 10 до 18	от 18 до 30	от 30 до 50	от 50 до 80	от 80 до 120
IT 5	4	5	6	8	9	11	13	15
IT 6	6	8	9	11	13	16	19	22
IT 7	10	12	15	18	21	25	30	35
IT 8	14	18	22	27	33	39	46	54
IT 9	25	30	36	43	52	62	74	87
IT 10	40	48	58	70	84	100	120	140
IT 11	60	75	90	110	130	160	190	220
IT 12	100	120	150	180	210	250	300	350

ПРИМЕРЫ РАСЧЕТА

Пример расчета для отверстия диаметром 10 D8 мм

Макс. диаметр отверстия = 10,062

Мин диаметр отверстия = 10,040

Поле допуска на диаметр (IT8) = 0,022

Для расчета макс. диаметра развертки из макс. диаметра отверстия вычитаем 0,15 от поля допуска для отверстия, округленных до 0,001 мм в большую сторону.

0,15 x поле допуска отверстия (IT8)=0,0033, округляем до 0,004 мм

Для расчета мин. диаметра развертки из макс. диаметра отверстия вычитаем 0,35 от поля допуска для отверстия, округленных до 0,001 мм в большую сторону.

0,35 x поле допуска отверстия (IT8) = 0,0077, округляем до 0,008 мм

Макс. диаметр развертки = 10,062 – 0,004 = 10,058

Мин. диаметр развертки = 10,058 – 0,008 = 10,050

Пример расчета диаметра изготавливаемых с шагом 0,01 мм разверток

Требуемое отверстие : d=4,25мм F8

Расчет: Номинальный диаметр отверстия + табличное значение для F8=1/100 развертка

4,25+0,02=4,27мм

Требуемый инструмент: Развертка диаметром 4,27 мм

Допуск (мм)															
Интервал d(мм)	A9	A11	B8	B9	B10	B11	C8	C9	C10	C11	D7	D8	D9	D10	D11
1-3	-	+0,31	-	-	+0,17	+0,18	-	-	+0,09	+0,10	-	-	-	+0,05	+0,06
3-6	+0,29	+0,32	+0,15	+0,16	+0,17	+0,19	+0,08	+0,09	+0,10	+0,12	-	+0,04	+0,05	+0,06	+0,08
6-10	+0,30	+0,35	+0,16	+0,17	+0,19	+0,22	+0,09	+0,10	+0,12	+0,15	-	+0,05	+0,06	+0,08	+0,11
10-18	+0,32	+0,37	-	+0,18	+0,20	+0,23	+0,11	+0,12	+0,14	+0,18	+0,06	+0,06	+0,08	+0,10	+0,13
	E7	E8	E9	F7	F8	F9	F10	G6	G7	H6	H7	H8	H9	H10	H11
1-3	-	+0,02	+0,03	+0,01	-	+0,02	-	-	-	-	-	-	-	+0,03	+0,04
3-6	-	+0,03	+0,04	-	+0,02	+0,03	+0,04	-	+0,01	-	-	+0,01	+0,02	+0,03	+0,05
6-10	-	-	+0,05	+0,02	-	+0,03	+0,05	-	-	-	-	+0,01	+0,02	+0,04	+0,07
10-18	+0,04	-	+0,06	-	+0,03	+0,04	+0,07	-	-	-	+0,01	-	+0,03	+0,05	+0,08
	H12	H13	J6	J7	J8	JS6	JS7	JS8	JS9	K7	K8	M6	M7	M8	N6
1-3	+0,08	+0,11	-	-	-	-	-	+0,00	+0,00	-	-	-	-	-	-
3-6	+0,09	+0,14	-	+0,00	+0,00	-	+0,00	+0,00	+0,00	-	-	-	-	-	-
6-10	+0,12	+0,18	-	+0,00	+0,00	-	+0,00	+0,00	+0,00	-	-	-	-	-0,01	-
10-18	+0,14	+0,22	-	+0,00	+0,00	-	+0,00	+0,00	+0,01	-	-	-0,01	-0,01	-0,01	-
	N7	N8	N9	N10	N11	P6	P7	R6	R7	S6	S7	U6	U7	U10	Z10
1-3	-0,01	-	-	-0,02	-0,02	-	-	-	-	-	-0,02	-	-	-	-0,04
3-6	-0,01	-0,01	-0,01	-0,02	-0,02	-	-	-	-	-	-	-	-	-0,04	-0,05
6-10	-	-	-	-0,02	-0,02	-	-	-	-	-	-	-	-0,03	-0,05	-0,06
10-18	-	-	-0,02	-0,02	-0,03	-	-0,02	-	-	-	-0,03	-	-	-0,05	-0,07

Допуски на изготовления разверток с шагом 0,01 мм стандартны и равны:

до диаметра 5,50мм = + 0,004/0

больше диаметра 5,50мм = + 0,005/0

УПРОЩЕННОЕ ВЫЧИСЛЕНИЕ ДОПУСТИМЫХ ПРЕДЕЛЬНЫХ РАЗМЕРОВ РАЗВЕРТОК

Пример: Поле допуска отверстия $\varnothing 20H7$ / номинальный размер d1 развертки 20 мм.

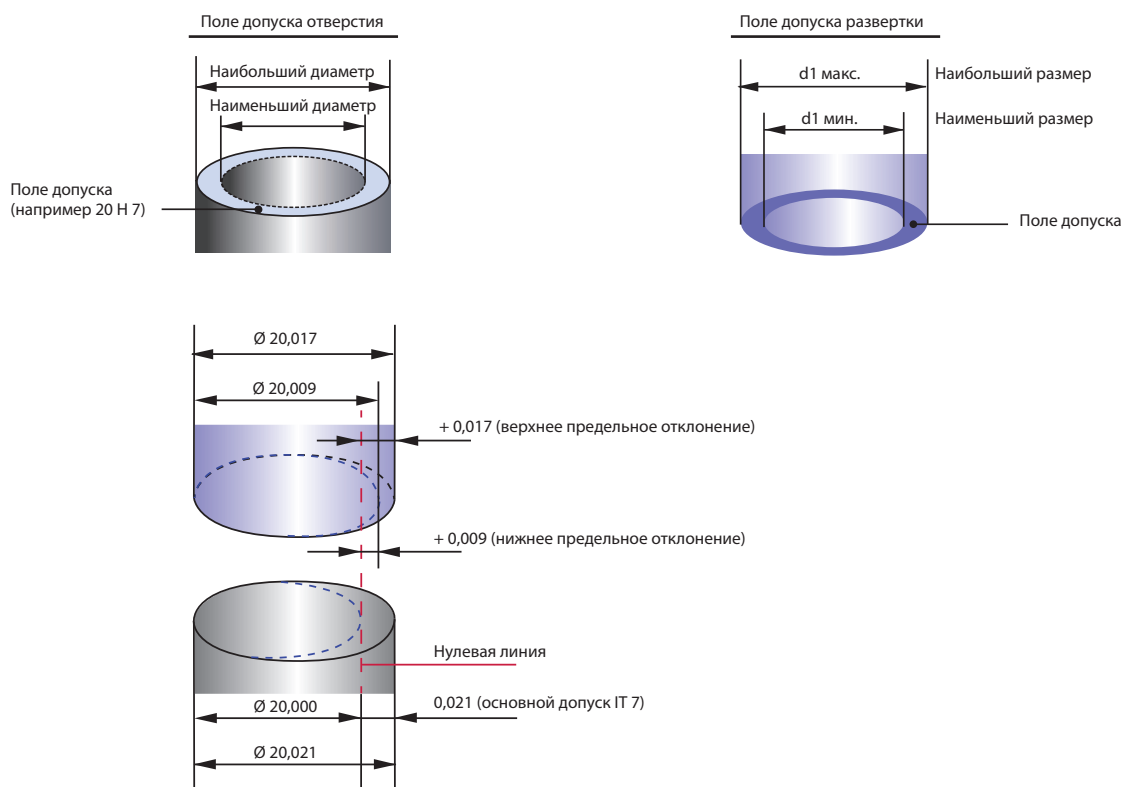

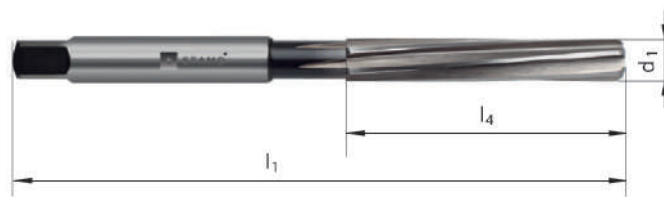

d1	DIN9		DIN206		DIN208		DIN212		DIN311		DIN859		DIN1895		DIN2180	
	l1	l4	l1	l4	l1	l4	l1	l4	l1	l4	l1	l4	l1	l4	l1	l4
MM	MM		MM		MM		MM		MM		MM		MM		MM	
≤0,60	38	20	-	-	-	-	-	-	-	-	-	-	-	-	-	-
≤0,85	42	24	-	-	-	-	-	-	-	-	-	-	-	-	-	-
≤1,06	46	28	-	-	-	-	-	-	-	-	-	-	-	-	-	-
≤1,32	50	32	-	-	-	-	34	5,5	-	-	-	-	-	-	-	-
≤1,50	57	37	41	20	-	-	40	8	-	-	-	-	-	-	-	-
≤1,70	-	-	44	21	-	-	43	9	-	-	-	-	-	-	-	-
≤1,90	-	-	47	23	-	-	46	10	-	-	-	-	-	-	-	-
≤2,12	68	48	50	25	-	-	49	11	-	-	-	-	-	-	-	-
≤2,36	-	-	54	27	-	-	53	12	-	-	-	-	-	-	-	-
≤2,65	68	48	58	29	-	-	57	14	-	-	-	-	-	-	-	-
≤3,00	80	58	62	31	-	-	61	15	-	-	-	-	-	-	-	-
≤3,35	-	-	66	33	-	-	65	16	-	-	-	-	-	-	-	-
≤3,75	-	-	71	35	-	-	70	18	-	-	-	-	-	-	-	-
≤4,25	93	68	76	38	-	-	75	19	-	-	76	38	-	-	-	-
≤4,75	-	-	81	41	-	-	80	21	-	-	81	41	-	-	-	-
≤5,30	100	73	87	44	133	23	86	23	-	-	87	44	-	-	155	73
≤6,00	135	105	93	47	138	26	93	26	-	-	93	47	-	-	187	105
≤6,70	-	-	100	50	144	28	101	28	151	75	100	50	137	61	-	-
≤7,50	-	-	107	54	150	31	109	31	156	80	107	54	-	-	-	-
≤8,50	180	145	115	58	156	33	117	33	161	85	115	58	-	-	227	145
≤9,50	-	-	124	62	162	36	125	36	166	90	124	62	-	-	-	-
≤10,60	215	175	133	66	168	38	133	38	171	95	133	66	142	66	257	175
≤11,80	-	-	142	71	175	41	142	41	176	100	142	71	-	-	-	-
≤13,20	255	210	152	76	182	44	151	44	199	105	152	76	-	-	315	210
≤14,00	-	-	-	-	189	47	160	47	209	115	-	-	-	-	-	-
≤15,00	280	230	163	81	204	50	162	50	219	125	163	81	173	79	-	-
≤16,00	-	-	-	-	210	52	170	52	229	135	-	-	-	-	335	230
≤17,00	-	-	175	87	214	54	175	54	251	135	175	87	-	-	-	-
≤18,00	-	-	-	-	219	56	182	56	-	-	-	-	-	-	-	-
≤19,00	-	-	188	93	223	58	189	58	261	145	188	93	-	-	-	-
≤20,00	310	250	201	100	228	60	195	60	-	-	-	-	-	-	377	250
≤21,20	-	-	-	-	232	62	-	-	271	155	201	100	212	96	-	-
≤22,40	-	-	215	107	237	64	-	-	-	-	-	-	-	-	-	-
≤23,60	-	-	-	-	241	66	-	-	281	165	215	107	-	-	-	-
≤25,00	370	300	-	-	268	68	-	-	-	-	-	-	-	-	427	300
≤26,50	-	-	231	115	273	70	-	-	296	180	231	115	263	119	-	-
≤28,00	-	-	-	-	277	71	-	-	-	-	-	-	-	-	-	-
≤30,00	400	320	247	124	281	73	-	-	311	195	247	124	-	-	475	320
≤31,50	-	-	-	-	285	75	-	-	326	210	-	-	-	-	-	-
≤33,50	-	-	265	133	317	77	-	-	354	210	265	133	-	-	-	-
≤35,50	-	-	-	-	321	78	-	-	-	-	-	-	-	-	-	-
≤37,50	-	-	284	142	325	79	-	-	364	220	284	142	-	-	-	-
≤40,00	430	340	-	-	329	81	-	-	374	230	-	-	331	150	495	340
≤42,50	-	-	305	152	333	82	-	-	-	-	305	152	-	-	-	-
≤45,00	-	-	-	-	336	83	-	-	-	-	-	-	-	-	-	-
≤47,50	-	-	326	163	340	84	-	-	384	240	326	163	-	-	-	-
≤50,00	460	360	347	174	344	86	-	-	394	250	347	174	-	-	550	360

развертки



ПРОБЛЕМА	ПРИЧИНА	СПОСОБ УСТРАНЕНИЯ
Быстрый износ инструмента	Слишком маленький припуск на обработку	Увеличить припуск на обработку (см. табл.)
Отверстие имеет форму овала или конуса	Смещение в шпинделе станка	Отремонтировать шпиндель станка
	Несимметричное расположение заборной части	Переточить до требуемых размеров
Сломанная или погнутая лапка	Плохой контакт между хвостовиком и патроном	Устранить загрязнения и повреждения на хвостовике и в патроне
Инструмент закусывается и ломается	Обратная конусность инструмента слишком мала	Проверить и заменить инструмент
	Неоднородный материал с твердыми включениями	Использовать твердосплавную развертку
	Слишком большой припуск на обработку	Уменьшить припуск на обработку (см. табл.)
	Инструмент изношен	Восстановить геометрию с помощью переточки инструмента
	Ширина ленточки слишком большая	Проверить и заменить инструмент
	Обрабатываемый материал склонен к усадке	Для компенсации усадки, использовать регулирующую развертку
Выход диаметра отверстия за пределы допуска	Слишком высокая подача или скорость	Выбрать режимы резания согласно рекомендациям из каталога
	Смещение в шпинделе станка	Отремонтировать шпиндель станка
	Увеличенная высота ленточки	Переточить до требуемого диаметра
	Овальность инструмента	Заменить или переточить инструмент
	Несимметричное расположение заборной части	Восстановить геометрию с помощью переточки инструмента
	Хвостовик инструмента поврежден	Заменить инструмент или перешлифовать хвостовик
	Дефект патрона	Заменить патрон
Плохое качество обработанной поверхности	Плохое качество СОЖ или низкая концентрация	Увеличить концентрацию
	Слишком маленькая/высокая подача или скорость резания	Выбрать режимы резания согласно рекомендациям из каталога
	Инструмент изношен	Восстановить геометрию с помощью переточки инструмента
	Слишком большой припуск на обработку	Уменьшить припуск на обработку (см. табл.)
	Слишком маленький передний угол	Восстановить геометрию с помощью переточки инструмента
Отверстие меньше требуемого размера	Недостаточная подача или скорость резания	Выбрать режимы резания согласно рекомендациям из каталога
	Просверленное отверстие имеет слишком маленький диаметр	Уменьшить припуск на обработку (см. табл.)
	Инструмент изношен	Восстановить геометрию с помощью переточки инструмента
	Слишком маленький припуск на обработку	Увеличить припуск на обработку (см. табл.)
	Чрезмерное выделение тепла при развертывании. Отверстие расширяется при обработке и затем усаживается.	Увеличить подачу СОЖ



УНИВЕРСАЛЬНОЕ ПРИМЕНЕНИЕ

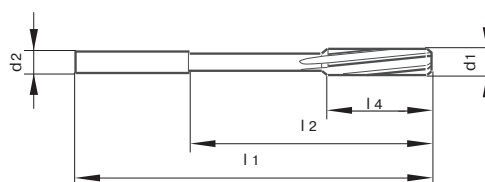

Система обозначений	
d1	диаметр режущей части, мм
d2	диаметр хвостовика, мм
L1	общая длина, мм
L2	длина обнуженной части, мм
L4	длина рабочей части, мм
Z	кол-во зубьев

Все размеры указаны в мм



Группы обрабатываемых материалов Основное применение	P	•	•				
	M	○	○				
	K	•	•				
	N	•	•				
	S	○	○				
Точность хвостовика	h6		h6				
Покрытие	(BR)		(BR)				
Стандарт	DIN 8093		DIN 8093				
d, mm	d2, mm	L, mm	L2, mm	L4, mm	Z	STR310001	STR310002
0,98	4	50	22	6	3	•	
0,99	4	50	22	6	3	•	
1	1	34	20	6	3		•
1	4	50	22	6	3	•	
1,01	4	50	22	6	3	•	
1,02	4	50	22	6	3	•	
1,03	4	50	22	9	3	•	
1,2	1	34	20	6	3		•
1,4	2	40	24	8	3		•
1,48	4	50	22	9	3	•	
1,49	4	50	22	9	3	•	
1,5	2	40	24	8	3		•
1,5	4	50	22	9	3	•	
1,51	4	50	22	9	3	•	
1,52	4	50	22	9	3	•	
1,53	4	50	22	9	3	•	
1,6	2	43	25	9	3		•
1,8	2	46	28	10	4		•
1,98	4	50	22	12	4	•	
1,99	4	50	22	12	4	•	
2	2	49	29	11	4		•
2	4	50	22	12	4	•	
2,01	4	50	22	12	4	•	
2,02	4	50	22	12	4	•	
2,03	4	50	22	12	4	•	
2,2	3	53	32	12	4		•
2,48	4	60	32	16	4	•	
2,49	4	60	32	16	4	•	
2,5	3	57	34	14	4		•
2,5	4	60	32	16	4	•	
2,51	4	60	32	16	4	•	
2,52	4	60	32	16	4	•	
2,53	4	60	32	16	4	•	
2,8	3	61	41	15	4		•
2,97	4	64	36	17	6	•	
2,98	4	64	36	17	6	•	
2,99	4	64	36	17	6	•	
3	3	61	41	15	6		•

Пример заказа: STR310001 d1,98 Выберите нужный размер и добавьте после артикула.

развертки



УНИВЕРСАЛЬНОЕ ПРИМЕНЕНИЕ

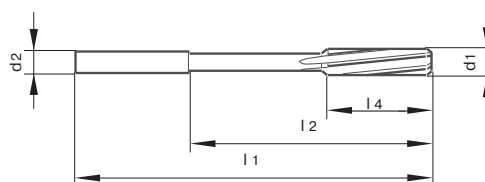

Система обозначений	
d1	диаметр режущей части, мм
d2	диаметр хвостовика, мм
L1	общая длина, мм
L2	длина обнуженной части, мм
L4	длина рабочей части, мм
Z	кол-во зубьев

Все размеры указаны в мм



						P	
Группы обрабатываемых материалов Основное применение						M	•
						K	•
						N	•
						S	•
						Точность хвостовика	
Покрытие						(BR)	(BR)
Стандарт						DIN 8093	DIN 8093
d, mm	d2, mm	L, mm	L2, mm	L4, mm	Z	STR310001	STR310002
3	4	64	36	17	6	•	•
3,01	4	64	36	17	6	•	
3,02	4	64	36	17	6	•	
3,03	4	64	36	17	6	•	
3,1	4	68	40	18	6		•
3,2	4	65	41	16	6		•
3,2	4	68	40	18	6		•
3,3	4	68	40	18	6		•
3,4	4	74	46	20	6		•
3,5	4	70	43	18	6		•
3,5	4	74	46	20	6		•
3,6	4	74	46	20	6		•
3,7	4	74	46	20	6		•
3,8	4	77	45	21	6		•
3,97	4	77	45	21	6	•	
3,98	4	77	45	21	6	•	
3,99	4	77	45	21	6	•	
4	4	75	43	19	6		•
4	4	77	45	21	6	•	•
4,01	4	77	45	21	6	•	
4,02	4	77	45	21	6	•	
4,03	4	77	45	21	6	•	
4,1	6	82	50	23	6		•
4,2	6	82	50	23	6		•
4,3	6	82	50	23	6		•
4,4	6	82	50	23	6		•
4,5	5	80	47	21	6		•
4,5	6	82	50	23	6		•
4,6	6	82	50	23	6		•
4,7	6	82	50	23	6		•
4,8	6	93	59	26	6		•
4,9	6	93	59	26	6		•
4,97	6	93	59	26	6	•	
4,98	6	93	59	26	6	•	
4,99	6	93	59	26	6	•	
5	5	86	52	23	6		•
5	6	93	59	26	6	•	•
5,01	6	93	59	26	6	•	

Пример заказа: STR310001 d1,98 Выберите нужный размер и добавьте после артикула.



УНИВЕРСАЛЬНОЕ ПРИМЕНЕНИЕ

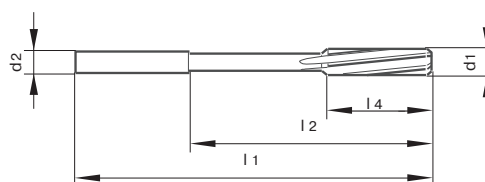

Система обозначений	
d1	диаметр режущей части, мм
d2	диаметр хвостовика, мм
L1	общая длина, мм
L2	длина обнуженной части, мм
L4	длина рабочей части, мм
Z	кол-во зубьев

Все размеры указаны в мм



Группы обрабатываемых материалов Основное применение	P	•	•				
	M	○	○				
	K	•	•				
	N	•	•				
	S	○	○				
Точность хвостовика	h6		h6				
Покрытие	BR		BR				
Стандарт	DIN 8093		DIN 8093				
d, mm	d2, mm	L, mm	L2, mm	L4, mm	Z	STR310001	STR310002
5,02	6	93	59	26	6	•	
5,03	6	93	59	26	6	•	
5,1	6	93	59	26	6		•
5,2	6	93	59	26	6		•
5,3	6	93	59	26	6		•
5,5	6	93	57	26	6		•
5,6	6	93	57	26	6		•
5,7	6	93	57	26	6		•
5,8	6	93	57	26	6		•
5,97	6	93	57	26	6	•	
5,98	6	93	57	26	6	•	
5,99	6	93	57	26	6	•	
6	6	93	57	26	6	•	•
6,01	6	93	57	26	6	•	
6,02	6	93	57	26	6	•	
6,03	6	93	57	26	6	•	
6,1	8	101	63	28	6		•
6,2	8	101	63	28	6		•
6,3	8	101	63	28	6		•
6,4	8	101	63	28	6		•
6,5	6	101	63	28	6		•
6,5	8	101	63	28	6		•
6,6	8	101	63	28	6		•
6,7	8	101	63	28	6		•
6,8	8	109	69	31	6		•
7	8	109	69	31	6	•	•
7,1	8	109	69	31	6		•
7,2	8	109	69	31	6		•
7,4	8	109	69	31	6		•
7,5	8	117	75	33	6		•
7,5	8	109	69	31	6		•
7,7	8	117	75	33	6		•
7,8	8	117	75	33	6		•
7,9	8	117	75	33	6		•
7,97	8	117	75	33	6	•	
7,98	8	117	75	33	6	•	
7,99	8	117	75	33	6	•	
8	8	117	75	33	6	•	•

Пример заказа: STR310001 d1,98 Выберите нужный размер и добавьте после артикула.

развертки



УНИВЕРСАЛЬНОЕ ПРИМЕНЕНИЕ

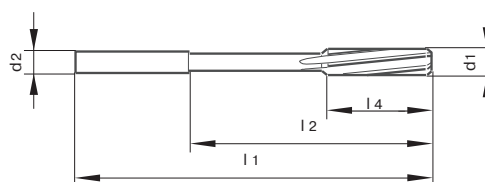

Система обозначений	
d1	диаметр режущей части, мм
d2	диаметр хвостовика, мм
L1	общая длина, мм
L2	длина обнуженной части, мм
L4	длина рабочей части, мм
Z	кол-во зубьев

Все размеры указаны в мм



Группы обрабатываемых материалов Основное применение	P	•	•				
	M	○	○				
Точность хвостовика	K	•	•				
	N	•	•				
	S	○	○				
Покрытие	h6		h6				
Стандарт	DIN 8093		DIN 8093				
d, mm	d2, mm	L, mm	L2, mm	L4, mm	Z	STR310001	STR310002
8,01	8	117	75	33	6	•	
8,02	8	117	75	33	6	•	
8,03	8	117	75	33	6	•	
8,04	8	117	75	33	6	•	
8,1	10	117	75	33	6		•
8,2	10	117	75	33	6		•
8,3	10	117	75	33	6		•
8,4	10	117	75	33	6		•
8,5	10	125	81	36	6		•
8,5	10	117	75	33	6		•
8,6	10	117	75	33	6		•
8,7	10	125	81	36	6		•
8,8	10	125	81	36	6		•
8,9	10	125	81	36	6		•
9	10	125	81	36	6	•	•
9,1	10	125	81	36	6		•
9,3	10	125	81	36	6		•
9,5	10	133	87	38	6		•
9,5	10	125	81	36	6		•
9,6	10	125	81	36	6		•
9,7	10	133	87	38	6		•
9,8	10	133	87	38	6		•
9,9	10	133	87	38	6		•
9,97	10	133	87	38	6	•	
9,98	10	133	87	38	6	•	
9,99	10	133	87	38	6	•	
10	10	133	87	38	6	•	•
10,01	10	133	87	38	6	•	
10,02	10	133	87	38	6	•	
10,03	10	133	87	38	6	•	
10,04	10	133	87	38	6	•	
10,05	10	133	87	38	6	•	
10,1	10	133	87	38	6		•
10,2	10	133	87	38	6		•
10,3	10	133	87	38	6		•
10,4	10	133	87	38	6		•
10,5	10	142	96	41	6		•
10,5	10	133	87	38	6		•

Пример заказа: STR310001 d1,98 Выберите нужный размер и добавьте после артикула.

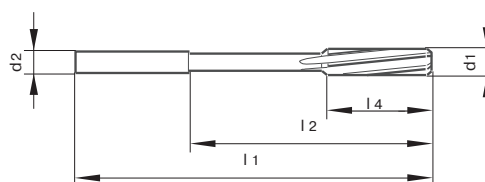

Система обозначений	
d1	диаметр режущей части, мм
d2	диаметр хвостовика, мм
L1	общая длина, мм
L2	длина обнуженной части, мм
L4	длина рабочей части, мм
Z	кол-во зубьев

Все размеры указаны в мм



Группы обрабатываемых материалов Основное применение	P	•	•				
	M	○	○				
	K	•	•				
	N	•	•				
	S	○	○				
Точность хвостовика	h6		h6				
Покрытие	BR		BR				
Стандарт	DIN 8093		DIN 8093				
d, mm	d2, mm	L, mm	L2, mm	L4, mm	Z	STR310001	STR310002
10,6	10	133	87	38	6		•
11	10	142	96	41	6		•
11,1	10	142	96	41	6		•
11,2	10	142	96	41	6		•
11,3	10	142	96	41	6		•
11,5	10	151	105	44	6		•
11,5	10	142	96	41	6		•
11,6	10	142	96	41	6		•
11,8	10	142	96	41	6		•
11,9	12	151	105	44	6		•
11,97	12	151	105	44	6	•	
11,98	12	151	105	44	6	•	
11,99	12	151	105	44	6	•	
12	12	151	105	44	6	•	•
12,01	12	151	105	44	6	•	
12,02	12	151	105	44	6	•	
12,03	12	151	105	44	6	•	
12,04	12	151	105	44	6	•	
12,05	12	151	105	44	6	•	
13	10	151	105	44	8		•
14	14	160	110	47	8		•
15	14	162	112	50	8		•
16	14	170	120	52	8		•
17	14	175	123	54	8		•
18	14	182	130	56	8		•
19	16	189	131	58	8		•
20	16	195	137	60	8		•

Пример заказа: STR310001 d1,98 Выберите нужный размер и добавьте после артикула.

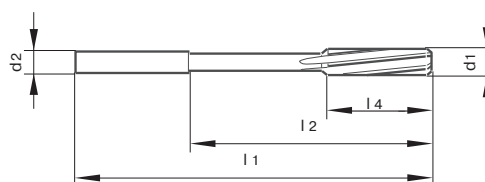

Система обозначений	
d1	диаметр режущей части, мм
d2	диаметр хвостовика, мм
L1	общая длина, мм
L2	длина обниженной части, мм
L4	длина рабочей части, мм
Z	кол-во зубьев

Все размеры указаны в мм



Группы обрабатываемых материалов Основное применение	P	•				
	M	○				
	K	•				
	N	•				
	S	○				
Точность хвостовика	h6					
Покрытие	BR					
Стандарт	DIN8093					
d, mm	d2, mm	L1, mm	L2, mm	L4, mm	z	STR310003
0,90–1,30	1,0	34	20	6	3	•
1,31–1,50	2,0	40	24	8	3	•
1,51–1,61	2,0	43	25	9	3	•
1,62–1,70	2,0	43	25	9	4	•
1,71–1,90	2,0	46	28	10	4	•
1,91–2,12	2,0	49	29	11	4	•
2,13–2,36	3,0	53	32	12	4	•
2,37–2,65	3,0	57	34	14	4	•
2,66–2,79	3,0	61	41	15	4	•
2,80–3,09	3,0	61	41	15	6	•
3,10–3,35	4,0	65	41	16	6	•
3,36–3,75	4,0	70	43	18	6	•
3,76–4,10	4,0	75	43	19	6	•
4,11–4,25	4,0	80	47	21	6	•
4,26–4,75	5,0	80	47	21	6	•
4,76–5,20	5,0	86	52	23	6	•
5,21–6,00	6,0	93	57	26	6	•
6,01–6,60	6,0	101	63	28	6	•
6,61–6,70	6,0	109	69	31	6	•
6,71–7,50	8,0	109	69	31	6	•
7,51–8,50	8,0	117	75	33	6	•
8,51–9,50	10,0	125	81	36	6	•
9,51–10,60	10,0	133	87	38	6	•
10,61–11,80	10,0	142	96	41	6	•
11,81–12,25	10,0	151	105	44	6	•
12,26–13,20	10,0	151	105	44	8	•

Развертки с диаметром $d1 \leq 12,2$ мм изготавливаются из цельного твердого сплава.

Выше диаметра $d1 \geq 12,21$ режущая часть из цельного твердого сплава, хвостовик стальной.

Развертки с цилиндрическим хвостовиком (h6) предназначены для использования в станках с ЧПУ.

Достигается более точный и стабильный процесс изготовления отверстий, при зажиме инструмента в термо- или гидрпатронах.

Пример заказа: STR310003 d1,73

Выберите нужный размер до 0,01 и добавьте после артикула.



Развертки с прямыми канавками рекомендуются для глухих отверстий



Развертки с винтовыми канавками рекомендуются для сквозных отверстий

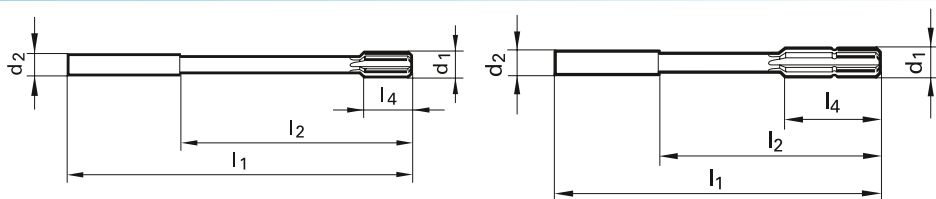

Система обозначений	
d1	диаметр режущей части, мм
d2	диаметр хвостовика, мм
L1	общая длина, мм
L2	длина обнуженной части, мм
L4	длина рабочей части, мм
Z	кол-во зубьев

Все размеры указаны в мм



Группы обрабатываемых материалов Основное применение	P	•	•	•	•	•	•	•	•				
	M	○	○	○	○	○	•	○	•				
	K	•	•	•	•	•	•	•	•				
	N	•	•	•	•	•	○	•	○				
	S	○	○	○	○	○	•	○	•				
Точность хвостовика		h9	h9	h6	h6	h6	h6	h6	h6				
Покрытие		BR	BR	BR	BR	BR	TiAIN	BR	TiAIN				
Стандарт		DIN 1809	DIN 1809	DIN 8050	DIN 8050	DIN 8093	DIN 8093	DIN 8093	DIN 8093				
d, mm	d2, mm	l1, mm	l2, mm	l4, mm	z	STR311041	STR310048	STR311030	STR310028	STR311020	STR311021	STR310040	STR310129
1,0	1,0	34	15,5	5,5	3								
1,2	1,2	38	17,1	7,5	3								
1,4	1,4	40	18,7	8	3								
1,5	1,5	40	18,8	8	3								
1,6	1,6	43	20,8	9	3								
1,8	1,8	46	22,9	10	4								
2,0	2,0	49	25	11	4								
2,2	2,2	53	26,1	12	4								
2,5	2,5	57	30,3	14	4								
2,8	2,8	61	34,4	15	4								
3,0	3,0	61	34,5	15	6								
3,2	3,2	65	38,6	16	6								
3,5	3,5	70	43,8	18	6								
4,0	4,0	75	43	19	6								
4,5	4,5	80	47	21	6								
5,0	5,0	86	52	12	6								
5,0	5,0	86	52	16	4	•	•						
5,0	5,0	86	52	23	6								
5,5	5,6	93	57	26	6								
6,0	5,6	93	57	12	6								
6,0	5,6	93	57	16	4	•	•						
6,0	5,6	93	57	26	6								
6,5	6,3	101	63	28	6								
7,0	7,1	109	69	16	4								
7,0	7,1	109	69	16	6	•	•						
7,0	7,1	109	69	31	6								
7,5	7,1	109	69	31	6								
8,0	8,0	117	75	16	4	•	•						
8,0	8,0	117	75	16	6								
8,0	8,0	117	75	33	6								
8,5	8,0	117	75	33	6								
9,0	9,0	125	81	19	4	•	•						
9,0	9,0	125	81	19	6								
9,0	9,0	125	81	36	6								
9,5	9,0	125	81	36	6								
10,0	10,0	133	87	12	6								
10,0	10,0	133	87	19	6	•	•						
10,0	10,0	133	87	38	6								
10,5	10,0	133	87	39	6								



Развертки с прямыми канавками рекомендуются для глухих отверстий



Развертки с винтовыми канавками рекомендуются для сквозных отверстий

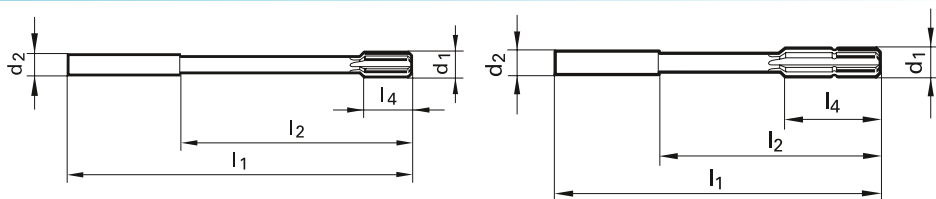

Система обозначений	
d1	диаметр режущей части, мм
d2	диаметр хвостовика, мм
L1	общая длина, мм
L2	длина обнуженной части, мм
L4	длина рабочей части, мм
Z	кол-во зубьев

Все размеры указаны в мм



Группы обрабатываемых материалов Основное применение	P	•	•	•	•	•	•	•	•				
	M	○	○	○	○	○	○	○	○				
	K	•	•	•	•	•	•	•	•				
	N	•	•	•	•	•	○	○	○				
	S	○	○	○	○	○	○	○	○				
Точность хвостовика		h9	h9	h6	h6	h6	h6	h6	h6				
Покрытие		BR	BR	BR	BR	BR	TiAIN	BR	TiAIN				
Стандарт		DIN 1809	DIN 1809	DIN 8050	DIN 8050	DIN 8093	DIN 8093	DIN 8093	DIN 8093				
d, mm	d2, mm	l1, mm	l2, mm	l4, mm	z	STR311041	STR310048	STR311030	STR310028	STR311020	STR311021	STR310040	STR310129
11,0	10,0	142	96	12	6								
11,0	10,0	142	96	19	6	•	•						
11,0	10,0	142	96	41	6					•	•	•	•
12,0	10,0	151	105	12	6			•	•				
12,0	10,0	151	105	19	6	•	•						
12,0	10,0	151	105	44	6					•	•	•	•
13,0	10,0	151	105	12	6			•	•				
13,0	10,0	151	105	19	6	•	•						
13,0	10,0	151	105	44	6					•	•	•	•
14,0	12,0	160	110	16	6			•	•				
14,0	12,5	160	110	19	6	•	•						
14,0	12,0	160	110	47	6					•	•	•	•
15,0	12,0	162	112	16	6			•	•				
15,0	12,5	162	112	19	6	•	•						
15,0	12,0	162	112	50	6					•	•	•	•
16,0	12,0	170	120	19	6			•	•				
16,0	12,5	170	120	22	6	•	•						
16,0	12,0	170	120	52	6					•	•	•	•
17,0	14,0	175	123	22	6	•	•						
17,0	14,0	175	123	54	6								•
18,0	14,0	182	130	19	6				•				
18,0	14,0	182	130	22	6	•	•						
18,0	14,0	182	130	56	6					•	•	•	•
19,0	16,0	189	131	22	6	•	•						
19,0	16,0	189	131	58	6					•	•	•	•
20,0	16,0	195	137	19	6			•	•				
20,0	16,0	195	137	22	6	•	•						
20,0	16,0	195	137	60	6					•	•	•	•

< Ø9,5 мм монолитный твердый сплав, с обеих сторон с наружными центрами.
> Ø9,50 мм тв. сплавные режущие пластины, с обеих сторон с внутренними центрами.

Пример заказа: STR310003 d8,0

Выберите нужный размер и добавьте после артикула.

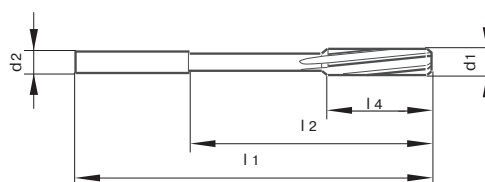
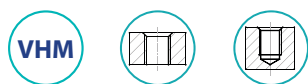

Система обозначений	
d1	диаметр режущей части, мм
d2	диаметр хвостовика, мм
L1	общая длина, мм
L2	длина обнуженной части, мм
L4	длина рабочей части, мм
Z	кол-во зубьев

Все размеры указаны в мм

Группы обрабатываемых материалов Основное применение							P	•
							M	○
Точность хвостовика							K	•
							N	•
Покрытие							S	○
							Стандарт	
Стандарт							OCT	
d, mm	d2, mm	l1, mm	l2, mm	l4, mm	z	STR310004		
0,10-0,19	1,50	35	10	5	4	•		
0,20-0,29	1,50	35	10	5	4	•		
0,30-0,47	1,50	35	10	5	4	•		
0,48-0,53	1,50	35	10	5	4	•		
0,54-0,59	1,50	35	10	5	4	•		
0,60-0,69	1,50	35	12	6	4	•		
0,70-0,79	1,50	35	12	6	4	•		
0,80-0,90	1,50	35	15	6	4	•		
0,91-1,00	1,50	35	15	8	4	•		
1,01-1,20	1,50	35	17	10	4	•		
1,21-1,50	1,50	40	23	12	4	•		
1,51-2,00	2,0	45	28	16	4	•		
2,01-2,40	2,0-3,0	50	31	18	4	•		
2,41-2,70	3,0	55	34	20	4	•		
2,71-3,10	3,0	60	39	20	4	•		
3,11-3,70	4,0	60	37	22	4-6	•		
3,71-4,10	4,0	65	40	24	6	•		
4,11-4,60	5,0	65	40	24	6	•		
4,61-4,90	5,0	65	38	26	6	•		
4,91-5,20	5,0	75	48	26	6	•		
5,21-5,70	5,0	75	48	26	6	•		
5,71-6,20	5,0-6,0	75	48	26	6	•		
6,21-6,60	6,0	80	49	30	6	•		
6,61-6,90	6,0-7,0	80	49	30	6	•		
6,91-7,20	7,0	95	59	35	6	•		
7,21-7,70	7,0	95	59	35	6	•		
7,71-8,20	7,0-8,0	95	59	35	6	•		
8,21-8,70	8,0	100	64	35	6	•		
8,71-8,90	8,0-9,0	100	64	35	6	•		
8,91-9,20	9,0	100	64	35	6	•		
9,21-9,70	9,0	100	64	35	6	•		
9,71-9,90	9,0-10,0	100	64	35	6	•		
9,91-10,70	10,0	100	64	35	6	•		
10,71-10,90	10,0-11,0	100	64	35	6	•		
10,91-11,20	11,0	100	64	35	6	•		
11,21-11,70	11,0	100	64	35	6	•		
11,71-11,90	11,0-12,0	100	64	35	6	•		
11,91-12,60	12,0	100	64	35	6	•		
12,61-12,90	12,0-13,0	100	64	35	6	•		
12,91-13,52	13,0	100	64	35	6	•		
13,90-14,10	14,0	100	64	35	6	•		
14,90-15,10	14,0	100	64	35	6	•		
15,90-16,10	16,0	100	64	35	6	•		
17,90-18,10	18,0	100	64	35	6	•		
19,90-20,10	20,0	100	64	35	6	•		

Развертки с цилиндрическим хвостовиком (h6) предназначены для использования в станках с ЧПУ.

Достигается более точный и стабильный процесс изготовления отверстий, при зажиме инструмента в термо- или гидротронах.

Пример заказа: STR310003 d1,73

Выберите нужный размер до 0,01 и добавьте после артикула.

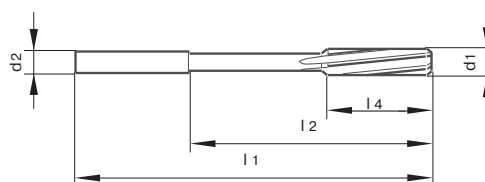
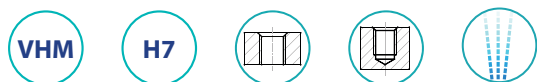

Система обозначений	
d1	диаметр режущей части, мм
d2	диаметр хвостовика, мм
L1	общая длина, мм
L2	длина обнуженной части, мм
L4	длина рабочей части, мм
Z	кол-во зубьев

Все размеры указаны в мм

Группы обрабатываемых материалов Основное применение	P	•	•				
	M	○	○				
	K	•	•				
	N	•	•				
	S	○	○				
Точность хвостовика	h9		h9				
Покрытие	BR		BR				
Стандарт	DIN 8093		DIN 8093				
d, mm	d2, mm	L1, mm	L2, mm	L4, mm	z	STR311015	STR313112
1,0	1,0	34	20	6	3	•	
1,2	1,2	34	20	6	3	•	
1,4	1,4	40	24	8	3	•	
1,5	1,5	40	24	8	3	•	
1,6	1,6	43	25	9	3	•	
1,8	1,8	46	28	10	4	•	
2,0	2,0	49	29	11	4	•	
2,2	2,2	53	32	12	4	•	
2,5	2,5	57	34	14	4	•	
2,8	2,8	61	41	15	6	•	
3,0	3,0	61	41	15	6	•	
3,2	3,2	65	41	16	6	•	
3,5	3,5	70	43	18	6	•	
4,0	4,0	75	43	19	6	•	•
4,5	4,5	80	47	21	6	•	•
5,0	5,0	86	52	23	6	•	•
5,5	5,6	93	57	26	6	•	•
6,0	5,6	93	57	26	6	•	•
6,5	6,3	101	63	28	6	•	•
7,0	7,1	109	69	31	6	•	•
7,5	8,0	117	75	33	6	•	•
8,0	8,0	117	75	33	6	•	•
8,5	9,0	125	81	36	6	•	•
9,0	9,0	125	81	36	6	•	•
9,5	10,0	133	87	38	6	•	•
10,0	10,0	133	87	38	6	•	•
10,5	10,0	142	96	41	6	•	•
11,0	10,0	142	96	41	6	•	•
11,5	10,0	151	105	44	6	•	•
12,0	10,0	151	105	44	6	•	•
13,0	10,0	151	105	44	8	•	•
14,0	12,5	160	110	47	8	•	•
15,0	14,0	162	112	50	8	•	•
16,0	14,0	170	120	52	8	•	•
17,0	14,0	175	123	54	8	•	•
18,0	14,0	182	130	56	8	•	•
19,0	16,0	189	131	58	8	•	•
20,0	16,0	195	137	60	8	•	•

Развертки с диаметром $d1 \leq 12,2$ мм изготавливаются из цельного твердого сплава. Выше диаметра $d1 \geq 12,21$ режущая часть из цельного твердого сплава, хвостовик стальной. Развертки с цилиндрическим хвостовиком (h6) предназначаются для использования в станках с ЧПУ. Достигается более точный и стабильный процесс изготовления отверстий, при зажиме инструмента в термо- или гидропатронах.

Пример заказа: STR310003 d8,0
выберите нужный размер и добавьте после артикула.

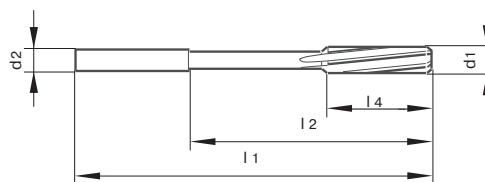

Система обозначений	
d1	диаметр режущей части, мм
d2	диаметр хвостовика, мм
L1	общая длина, мм
L2	длина обнуженной части, мм
L4	длина рабочей части, мм
Z	кол-во зубьев

Все размеры указаны в мм



Группы обрабатываемых материалов Основное применение	P	•	•				
	M	○	○				
	K	•	•				
	N	•	•				
	S	○	○				
Точность хвостовика		h9	h9				
Покрытие		BR	BR				
Стандарт		DIN 8093	DIN 8093				
d, mm	d2, mm	L1, mm	L2, mm	L4, mm	z	STR311060	STR310061
5,0	5,0	86	52	30	4	•	•
6,0	5,6	93	57	30	4	•	•
7,0	7,1	109	69	30	4	•	•
8,0	8,0	117	75	30	4	•	•
9,0	9,0	125	81	30	4	•	•
10,0	10,0	133	87	45	6	•	•
11,0	10,0	142	96	45	6	•	•
12,0	10,0	151	105	45	6	•	•
13,0	10,0	151	105	45	6	•	•
14,0	12,5	160	110	45	6	•	•
15,0	12,5	162	112	45	6	•	•
16,0	12,5	170	120	56	6	•	•
17,0	14,0	175	123	56	6	•	•
18,0	14,0	182	130	56	6	•	•
19,0	16,0	189	131	56	6	•	•
20,0	16,0	195	137	56	6	•	•

Пример заказа: STR311060 d8,0

Выберите нужный размер и добавьте после артикула.



УНИВЕРСАЛЬНОЕ ПРИМЕНЕНИЕ

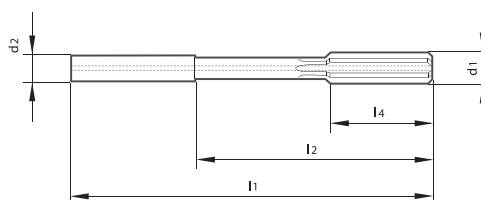

Система обозначений	
d1	диаметр режущей части, мм
d2	диаметр хвостовика, мм
L1	общая длина, мм
L2	длина обнуженной части, мм
L4	длина рабочей части, мм
Z	кол-во зубьев

Все размеры указаны в мм

Группы обрабатываемых материалов Основное применение	P	•	•	•	•				
	M	•	•	•	•				
	K	○	○	○	○				
	N	•	•	•	•				
	S	•	•	•	•				
Точность хвостовика		h6	h6	h6	h6				
Покрытие		TIAlN	TIAlN	TIAlN	TIAlN				
Стандарт		OCT	OCT	OCT	OCT				
d, mm	d2, mm	l1, mm	l2, mm	l4, mm	z	STR311150	STR311151	STR310160	STR310161
2,97	4	68	40	12	4		•		•
2,98	4	68	40	12	4		•		•
2,99	4	68	40	12	4		•		•
3	4	68	40	12	4	•	•	•	•
3,01	4	68	40	12	4		•		•
3,02	4	68	40	12	4		•		•
3,03	4	68	40	12	4		•		•
3,5	4	68	40	12	4	•		•	
3,97	4	68	40	12	4		•		•
3,98	4	68	40	12	4		•		•
3,99	4	68	40	12	4		•		•
4	4	68	40	12	4	•	•	•	•
4,01	4	68	40	12	4		•		•
4,02	4	68	40	12	4		•		•
4,03	4	68	40	12	4		•		•
4,5	6	76	40	12	4	•		•	
4,97	6	76	40	12	4		•		•
4,98	6	76	40	12	4		•		•
4,99	6	76	40	12	4		•		•
5	6	76	40	12	4	•	•	•	•
5,01	6	76	40	12	4		•		•
5,02	6	76	40	12	4		•		•
5,03	6	76	40	12	4		•		•
5,5	6	76	40	12	4	•		•	
5,97	6	76	40	12	4		•		•
5,98	6	76	40	12	4		•		•
5,99	6	76	40	12	4		•		•
6	6	76	40	12	4	•	•	•	•
6,01	6	76	40	12	4		•		•
6,02	6	76	40	12	4		•		•
6,03	6	76	40	12	4		•		•
6,5	8	101	65	16	6	•		•	
7	8	101	65	16	6	•	•	•	•
7,5	8	101	65	16	6	•		•	
7,97	8	101	65	16	6		•		•
7,98	8	101	65	16	6		•		•
7,99	8	101	65	16	6		•		•
8	8	101	65	16	6	•	•	•	•
8,01	8	101	65	16	6		•		•

развертка



УНИВЕРСАЛЬНОЕ ПРИМЕНЕНИЕ

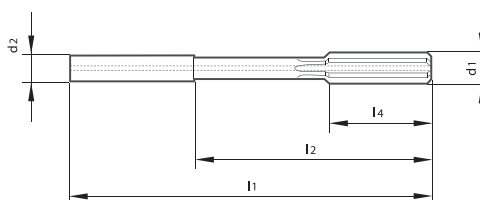

Система обозначений	
d1	диаметр режущей части, мм
d2	диаметр хвостовика, мм
L1	общая длина, мм
L2	длина обнуженной части, мм
L4	длина рабочей части, мм
Z	кол-во зубьев

Все размеры указаны в мм

Группы обрабатываемых материалов Основное применение	P	•	•	•	•				
	M	•	•	•	•				
	K	○	○	○	○				
	N	•	•	•	•				
	S	•	•	•	•				
Точность хвостовика		h6	h6	h6	h6				
Покрытие		TiAlN	TiAlN	TiAlN	TiAlN				
Стандарт		OCT	OCT	OCT	OCT				
d, mm	d2, mm	l1, mm	l2, mm	l4, mm	z	STR311150	STR311151	STR310160	STR310161
8,02	8	101	65	16	6	•	•	•	•
8,03	8	101	65	16	6				
8,5	10	101	61	19	6	•		•	
9	10	101	61	19	6	•	•	•	•
9,5	10	101	61	19	6	•		•	
9,97	10	101	61	19	6		•		•
9,98	10	101	61	19	6		•		•
9,99	10	101	61	19	6		•		•
10	10	101	61	19	6	•	•	•	•
10,01	10	101	61	19	6		•		•
10,02	10	101	61	19	6		•		•
10,03	10	101	61	19	6		•		•
10,5	12	130	85	19	6	•		•	
11	12	130	85	19	6	•	•	•	•
11,5	12	130	85	19	6	•		•	
11,97	12	130	85	19	6		•		•
11,98	12	130	85	19	6		•		•
11,99	12	130	85	19	6		•		•
12	12	130	85	19	6	•	•	•	•
12,01	12	130	85	19	6		•		•
12,02	12	130	85	19	6		•		•
12,03	12	130	85	19	6		•		•
13	14	130	85	22	6	•		•	
14	14	130	85	22	6	•		•	
15.000	16	150	102	22	6	•		•	
16.000	16	150	102	22	6	•		•	
17.000	18	150	102	25	6	•		•	
18.000	18	150	102	25	6	•		•	
19.000	20	150	100	25	6	•		•	
20.000	20	150	100	25	6	•		•	

Развертки с цилиндрическим хвостовиком (h6) предназначены для использования в станках с ЧПУ. Достигается более точный и стабильный процесс изготовления отверстий, при зажиме инструмента в термо- или гидротронах.

развертки

УНИВЕРСАЛЬНОЕ ПРИМЕНЕНИЕ

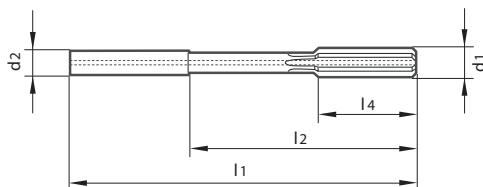
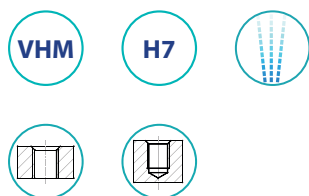

Система обозначений	
d1	диаметр режущей части, мм
d2	диаметр хвостовика, мм
L1	общая длина, мм
L2	длина обнуженной части, мм
L4	длина рабочей части, мм
Z	кол-во зубьев

Все размеры указаны в мм

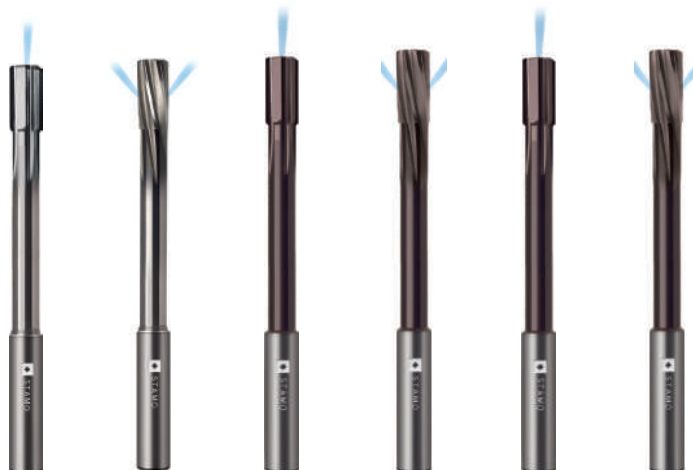

Группы обрабатываемых материалов Основное применение	P	○	○	●	●	●	●				
	M	○	○	○	○	●	●				
	K	○	○	●	●	○	○				
	N	●	●	○	○	○	○				
	S	○	○	○	○	●	●				
Точность хвостовика		h6	h6	h6	h6	h6	h6				
Покрытие		BR	BR	TIAlN	TIAlN	TIAlN	TIAlN				
Стандарт		OCT	OCT	OCT	OCT	OCT	OCT				
d, mm	d2, mm	l1, mm	l2, mm	l4, mm	z	STR310140	STR311140	STR310170	STR311170	STR310180	STR311180
4,0	4,0	75	47	12	4	●	●	●	●	●	●
4,5	6,0	75	39	12	4	●	●	●	●	●	●
5,0	6,0	75	39	12	4	●	●	●	●	●	●
5,5	6,0	75	39	16	4	●	●	●	●	●	●
6,0	6,0	75	39	16	4	●	●	●	●	●	●
6,5	8,0	100	64	16	6	●	●	●	●	●	●
7,0	8,0	100	64	16	6	●	●	●	●	●	●
7,5	8,0	100	64	16	6	●	●	●	●	●	●
8,0	8,0	100	64	16	6	●	●	●	●	●	●
8,5	10,0	100	60	19	6	●	●	●	●	●	●
9,0	10,0	100	60	19	6	●	●	●	●	●	●
9,5	10,0	120	80	19	6	●	●	●	●	●	●
10,0	10,0	120	80	19	6	●	●	●	●	●	●
10,5	12,0	120	75	19	6	●	●	●	●	●	●
11,0	12,0	120	75	19	6	●	●	●	●	●	●
11,5	12,0	120	75	19	6	●	●	●	●	●	●
12,0	12,0	120	75	19	6	●	●	●	●	●	●
13,0	14,0	120	75	19	6	●	●	●	●	●	●
14,0	14,0	135	90	22	6	●	●	●	●	●	●
15,0	16,0	135	87	22	6	●	●	●	●	●	●
16,0	16,0	135	87	22	6	●	●	●	●	●	●
17,0	18,0	145	97	22	8	●	●	●	●	●	●
18,0	18,0	145	97	22	8	●	●	●	●	●	●
19,0	20,0	145	95	22	8	●	●	●	●	●	●
20,0	20,0	145	95	22	8	●	●	●	●	●	●

Пример заказа: STR310003 d8,0
Выберите нужный размер и добавьте после артикула.



УНИВЕРСАЛЬНОЕ ПРИМЕНЕНИЕ

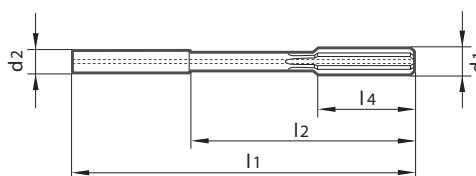

Система обозначений	
d1	диаметр режущей части, мм
d2	диаметр хвостовика, мм
L1	общая длина, мм
L2	длина обнуженной части, мм
L4	длина рабочей части, мм
Z	кол-во зубьев

Все размеры указаны в мм



Группы обрабатываемых материалов Основное применение	P	•	•				
	M	○	○				
	K	•	•				
	N	○	○				
	S	○	○				
Точность хвостовика	h6		h6				
Покрытие	TiAlN		TiAlN				
Стандарт	OCT		OCT				
d, mm	d2, mm	L1, mm	L2, mm	L4, mm	z	STR310190	STR311190
3,97	4,0	75	47	12	4	•	•
3,98	4,0	75	47	12	4	•	•
3,99	4,0	75	47	12	4	•	•
4,00	4,0	75	47	12	4	•	•
4,01	4,0	75	47	12	4	•	•
4,02	4,0	75	47	12	4	•	•
4,03	4,0	75	47	12	4	•	•
4,97	6,0	75	39	12	4	•	•
4,98	6,0	75	39	12	4	•	•
4,99	6,0	75	39	12	4	•	•
5,00	6,0	75	39	12	4	•	•
5,01	6,0	75	39	12	4	•	•
5,02	6,0	75	39	12	4	•	•
5,03	6,0	75	39	12	4	•	•
5,97	6,0	75	39	16	4	•	•
5,98	6,0	75	39	16	4	•	•
5,99	6,0	75	39	16	4	•	•
6,00	6,0	75	39	16	4	•	•
6,01	6,0	75	39	16	4	•	•
6,02	6,0	75	39	16	4	•	•
6,03	6,0	75	39	16	4	•	•
7,97	8,0	100	64	16	6	•	•
7,98	8,0	100	64	16	6	•	•
7,99	8,0	100	64	16	6	•	•
8,00	8,0	100	64	16	6	•	•
8,01	8,0	100	64	16	6	•	•
8,02	8,0	100	64	16	6	•	•
8,03	8,0	100	64	16	6	•	•
9,97	10,0	120	80	19	6	•	•
9,98	10,0	120	80	19	6	•	•



УНИВЕРСАЛЬНОЕ ПРИМЕНЕНИЕ

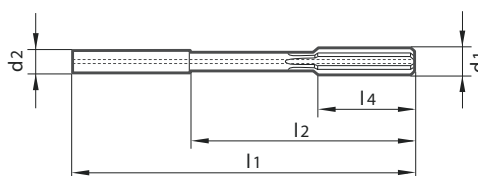

Система обозначений	
d1	диаметр режущей части, мм
d2	диаметр хвостовика, мм
L1	общая длина, мм
L2	длина обнуженной части, мм
L4	длина рабочей части, мм
Z	кол-во зубьев

Все размеры указаны в мм



Группы обрабатываемых материалов Основное применение	P	•	•				
	M	○	○				
	K	•	•				
	N	○	○				
	S	○	○				
Точность хвостовика		h6	h6				
Покрытие		TiAlN	TiAlN				
Стандарт		OCT	OCT				
d, mm	d2, mm	l1, mm	l2, mm	l4, mm	z	STR310190	STR311190
9,99	10,0	120	80	19	6	•	•
10,00	10,0	120	80	19	6	•	•
10,01	10,0	120	80	19	6	•	•
10,02	10,0	120	80	19	6	•	•
10,03	10,0	120	80	19	6	•	•
11,97	12,0	120	75	19	6	•	•
11,98	12,0	120	75	19	6	•	•
11,99	12,0	120	75	19	6	•	•
12,00	12,0	120	75	19	6	•	•
12,01	12,0	120	75	19	6	•	•
12,02	12,0	120	75	19	6	•	•
12,03	12,0	120	75	19	6	•	•

Пример заказа: STR310003 d8,03

Выберите нужный размер и добавьте после артикула.

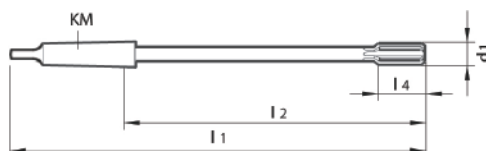

Система обозначений	
d1	диаметр режущей части, мм
d2	диаметр хвостовика, мм
L1	общая длина, мм
L2	длина обнуженной части, мм
L4	длина рабочей части, мм
Z	кол-во зубьев

Все размеры указаны в мм

Группы обрабатываемых материалов Основное применение	P	•	•				
	M	○	○				
	K	•	•				
	N	•	•				
	S	○	○				
Покрытие	(BR)		(BR)				
Стандарт	DIN 8051		DIN 8051				
d1	L1	L2	L4	MK	Z	STR311091	STR310091
5,0	133	71	12	1	6	•	
6,0	138	76	12	1	6	•	•
7,0	150	88	16	1	6	•	
8,0	156	94	16	1	6	•	•
10,0	168	106	12	1	6	•	•
11,0	175	113	12	1	6	•	•
12,0	182	120	12	1	6	•	•
13,0	182	120	12	1	6	•	•
14,0	189	127	16	1	6	•	•
15,0	204	129	16	2	6	•	•
16,0	210	135	19	2	6	•	•
17,0	214	139	19	2	6	•	
18,0	219	144	19	2	6	•	•
20,0	228	153	19	2	6	•	•
21,0	232	157	22	2	6	•	
22,0	237	162	22	2	6	•	•
23,0	241	166	22	2	6	•	
24,0	268	174	22	3	8	•	•
25,0	268	174	22	3	8	•	•
26,0	273	179	22	3	8	•	•
28,0	277	183	25	3	8	•	
30,0	281	187,0	25	3	8	•	•
32,0	317	199,5	25	4	8	•	•
40,0	329	211,5	25	4	8	•	

≤ Ø9,5 мм монолитный твердый сплав, с обеих сторон с наружными центрами.

≥ Ø9,50 мм тв. сплавные режущие пластины, с обеих сторон с внутренними центрами.

Пример заказа: STR311091 d8,0

Выберите нужный размер и добавьте после артикула.

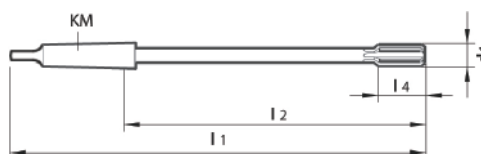

Система обозначений	
d1	диаметр режущей части, мм
d2	диаметр хвостовика, мм
L1	общая длина, мм
L2	длина обнуженной части, мм
L4	длина рабочей части, мм
Z	кол-во зубьев

Все размеры указаны в мм



Группы обрабатываемых материалов Основное применение	P	•	•	•				
	M	○	○	○				
	K	•	•	•				
	N	•	•	•				
	S	○	○	○				
Покрытие	(BR)			(BR)	(BR)			
Стандарт	DIN 8094			DIN 8094	DIN 8094			
d1	L1	L2	L4	MK	Z	STR311092	STR310092	STR310093
5,0	133	67,5	23	1	6			•
5,0	133	67,5	30	1	4	•	•	
6,0	138	72,5	26	1	6			•
6,0	138	72,5	30	1	4	•	•	
7,0	150	84,5	31	1	6			•
7,0	150	84,5	30	1	4	•	•	
8,0	156	90,5	33	1	6			•
8,0	156	90,5	30	1	4	•	•	
9,0	162	96,5	36	1	6			•
9,0	162	96,5	30	1	4	•	•	
10,0	168	102,5	38	1	6			•
10,0	168	102,5	45	1	6	•	•	
11,0	175	109,5	41	1	6			•
11,0	175	109,5	45	1	6	•	•	
12,0	182	116,5	44	1	6			•
12,0	182	116,5	45	1	6	•	•	
13,0	182	116,5	44	1	6			•
13,0	182	116,5	45	1	6	•	•	
14,0	189	123,5	47	1	8			•
14,0	189	123,5	45	1	6	•	•	
15,0	204	124,0	50	2	8			•
15,0	204	124,0	45	2	6	•	•	
16,0	210	130,0	52	2	8			•
16,0	210	130,0	45	2	6	•	•	
17,0	214	134,0	54	2	8			•
17,0	214	134,0	56	2	6	•	•	
18,0	219	139,0	56	2	8			•
18,0	219	139,0	56	2	6	•	•	
19,0	223	143,0	58	2	8			•
19,0	223	143,0	56	2	6	•	•	
20,0	228	148,0	60	2	8			•
20,0	228	148,0	56	2	6	•	•	
21,0	232	152,0	56	2	6	•	•	
22,0	237	157,0	56	2	6	•	•	
23,0	241	161,0	56	2	6	•	•	
24,0	268	169,0	70	3	8	•	•	
25,0	268	169,0	70	3	8	•	•	

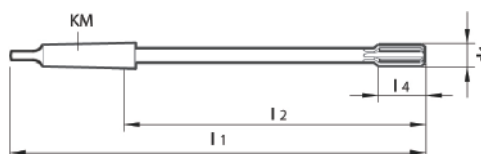

Система обозначений	
d1	диаметр режущей части, мм
d2	диаметр хвостовика, мм
L1	общая длина, мм
L2	длина обнуженной части, мм
L4	длина рабочей части, мм
Z	кол-во зубьев

Все размеры указаны в мм



Группы обрабатываемых материалов Основное применение	P	•	•	•				
	M	○	○	○				
	K	•	•	•				
	N	•	•	•				
	S	○	○	○				
Покрытие		BR	BR	BR				
Стандарт		DIN 8094	DIN 8094	DIN 8094				
d1	L1	L2	L4	MK	Z	STR311092	STR310092	STR310093
26,0	273	174,0	70	3	8	•	•	
27,0	277	178,0	70	3	8	•	•	
28,0	277	178,0	70	3	8	•	•	
29,0	281	182,0	70	3	8	•	•	
30,0	281	182,0	70	3	8	•	•	
31,0	285	186,0	70	3	8	•	•	
32,0	317	193,0	70	4	8	•	•	
34,0	321	197,0	70	4	8	•	•	
35,0	321	197,0	70	4	8	•	•	
36,0	325	201,0	70	4	8	•	•	
38,0	329	205,0	70	4	8	•	•	
40,0	329	205,0	70	4	8	•	•	

≤ Ø9,5 мм монолитный твердый сплав, с обеих сторон с наружными центрами.

≥ Ø9,50 мм тв. сплавные режущие пластины, с обеих сторон с внутренними центрами.

Пример заказа: STR311091 d8,0

Выберите нужный размер и добавьте после артикула.

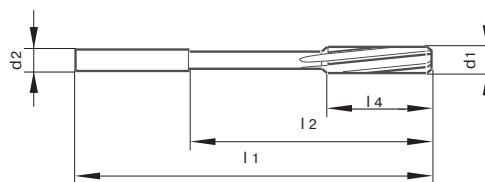

Система обозначений	
d1	диаметр режущей части, мм
d2	диаметр хвостовика, мм
L1	общая длина, мм
L2	длина обнуженной части, мм
L4	длина рабочей части, мм
Z	кол-во зубьев

Все размеры указаны в мм



Группы обрабатываемых материалов Основное применение	P	•	•				
	M	○	○				
	K	•	•				
	N	•	•				
	S	○	○				
Точность хвостовика	h8		h8				
Покрытие	BR		BR				
Стандарт	DIN 8089		DIN 8089				
d, mm	d2, mm	L1, mm	L2, mm	L4, mm	z	STR311016	STR310016
2,0	2,0	50	16	4	4	•	•
2,5	2,5	56	18	4	4	•	•
3,0	2,5	56	20	6	6	•	•
3,2	2,8	56	20	6	6	•	•
3,5	3,0	56	20	6	6	•	•
4,0	3,6	56	20	6	6	•	•
4,5	4,0	63	22	6	6	•	•
5,0	4,0	63	22	6	6	•	•
5,5	5,0	63	22	6	6	•	•
6,0	5,0	63	22	6	6	•	•
6,5	5,0	63	22	6	6	•	•
7,0	6,3	71	25	6	6	•	•
7,5	6,3	71	25	6	6	•	•
8,0	6,3	71	25	6	6	•	•
8,5	6,3	71	25	6	6	•	•
9,0	8,0	71	25	6	6	•	•
9,5	8,0	71	25	6	6	•	•
10,0	8,0	71	25	6	6	•	•
11,0	10,0	80	28	6	6	•	•
12,0	10,0	80	28	6	6	•	•
13,0	10,0	80	28	6	6	•	•
14,0	12,5	90	32	8	8	•	•
15,0	12,5	90	32	8	8	•	•
16,0	12,5	90	32	8	8	•	•
17,0	12,5	90	32	8	8	•	•
18,0	16,0	100	36	8	8	•	•
19,0	16,0	100	36	8	8	•	•
20,0	16,0	100	36	8	8	•	•

Пример заказа: STR311016 d8,0

Выберите нужный размер и добавьте после артикула.

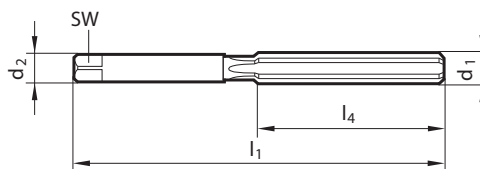

Система обозначений	
d1	диаметр режущей части, мм
d2	диаметр хвостовика, мм
L1	общая длина, мм
L2	длина обниженной части, мм
L4	длина рабочей части, мм
Z	кол-во зубьев

Все размеры указаны в мм



Группы обрабатываемых материалов Основное применение						P	•	•	
						M	○	○	
Покрытие						K	•	•	
						N	•	•	
						S	○	○	
Стандарт						DIN 206		DIN 206	
d, mm	d2, mm	1, mm	l4, mm	SW	z	STR101001		STR100001	
1,0	1,0	34	13	-	3	•	•	•	•
1,1	1,0	34	13	-	3	•	•	•	•
1,2	1,2	38	16	-	3	•	•	•	•
1,3	1,2	38	16	-	3	•	•	•	•
1,4	1,4	41	20	1,12	3	•	•	•	•
1,5	1,5	41	20	1,12	3	•	•	•	•
1,6	1,6	44	21	1,25	4	•	•	•	•
1,8	1,8	47	23	1,40	4	•	•	•	•
2,0	2,0	50	25	1,60	4	•	•	•	•
2,2	2,2	54	27	1,80	4	•	•	•	•
2,5	2,5	58	29	2,10	4	•	•	•	•
2,8	2,8	62	31	2,24	6	•	•	•	•
3,0	3,0	62	31	2,40	6	•	•	•	•
3,2	3,2	66	33	2,40	6	•	•	•	•
3,5	3,5	71	35	2,70	6	•	•	•	•
4,0	4,0	76	38	3,00	6	•	•	•	•
4,5	4,5	81	41	3,40	6	•	•	•	•
5,0	5,0	87	44	3,80	6	•	•	•	•
5,5	5,5	93	47	4,30	6	•	•	•	•
6,0	6,0	93	47	4,90	6	•	•	•	•
6,5	6,5	100	50	4,90	6	•	•	•	•
7,0	7,0	107	54	5,50	6	•	•	•	•
7,5	7,5	107	54	6,20	6	•	•	•	•
8,0	8,0	115	58	6,20	6	•	•	•	•
8,5	8,5	115	58	7,00	6	•	•	•	•
9,0	9,0	124	62	7,00	6	•	•	•	•
9,5	9,5	124	62	8,00	6	•	•	•	•
10,0	10,0	133	66	8,00	6	•	•	•	•
10,5	10,5	133	66	8,00	6	•	•	•	•
11,0	11,0	142	71	9,00	6	•	•	•	•
11,5	11,5	142	71	9,00	6	•	•	•	•
12,0	12,0	152	76	9,00	6	•	•	•	•
12,5	12,5	152	76	9,00	6	•	•	•	•
13,0	13,0	152	76	10,00	8	•	•	•	•
14,0	14,0	163	81	11,00	8	•	•	•	•
15,0	15,0	163	81	12,00	8	•	•	•	•
15,5	15,5	163	81	12,00	8	•	•	•	•
16,0	16,0	175	87	12,00	8	•	•	•	•

Пример заказа: STR101001 d4,0
Выберите нужный размер и добавьте после артикула.

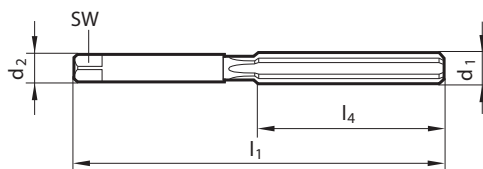

Система обозначений	
d1	диаметр режущей части, мм
d2	диаметр хвостовика, мм
L1	общая длина, мм
L2	длина обнуженной части, мм
L4	длина рабочей части, мм
Z	кол-во зубьев

Все размеры указаны в мм

Группы обрабатываемых материалов Основное применение						P	•	•
						M	○	○
Покрытие						K	•	•
						N	•	•
Стандарт						S	○	○
						DIN 206		
d, mm	d2, mm	l, mm	l4, mm	SW	z	STR101001	STR100001	
16,5	16,5	175	87	13,00	8	•	•	
17,0	17,0	175	87	13,00	8	•	•	
18,0	18,0	188	93	14,50	8	•	•	
19,0	19,0	188	93	14,50	8	•	•	
20,0	20,0	201	100	16,00	8	•	•	
21,0	21,0	201	100	16,00	8	•	•	
22,0	22,0	215	107	18,00	8	•	•	
23,0	23,0	215	107	18,00	10	•	•	
24,0	24,0	231	115	18,00	8	•	•	
25,0	25,0	231	115	20,00	8	•	•	
26,0	26,0	231	115	20,00	10	•	•	
27,0	27,0	247	124	22,40	10	•	•	
28,0	28,0	247	124	22,00	10	•	•	
29,0	29,0	247	124	22,40	10	•	•	
30,0	30,0	247	124	24,00	10	•	•	
31,0	31,0	265	133	24,00	10	•	•	
32,0	32,0	265	133	24,00	10	•	•	
33,0	33,0	265	133	26,00	10	•	•	
34,0	34,0	284	142	26,00	10	•	•	
35,0	35,0	284	142	29,00	10	•	•	
36,0	36,0	284	142	28,00	12	•	•	
37,0	37,0	284	142	28,00	12	•	•	
38,0	38,0	305	152	29,00	10	•	•	
39,0	39,0	305	152	31,50	12	•	•	
40,0	40,0	305	152	32,00	10	•	•	
41,0	41,0	305	152	31,50	12	•	•	
42,0	42,0	305	152	31,50	12	•	•	
43,0	43,0	326	163	35,00	12	•	•	
44,0	44,0	326	163	32,00	12	•	•	
45,0	45,0	326	163	35,50	14	•	•	
46,0	46,0	326	163	35,50	14	•	•	
47,0	47,0	347	174	40,00	14	•	•	
48,0	48,0	347	174	40,00	14	•	•	
49,0	49,0	347	174	39,00	12	•	•	
50,0	50,0	347	174	40,00	14	•	•	
51,0	51,0	347	174	40,00	14	•	•	
52,0	52,0	347	174	40,00	14	•	•	
53,0	53,0	347	174	40,00	14	•	•	
54,0	54,0	367	184	45,00	14	•	•	
55,0	55,0	367	184	45,00	16	•	•	
56,0	56,0	367	184	45,00	16	•	•	
57,0	57,0	367	184	45,00	16	•	•	
58,0	58,0	367	184	45,00	16	•	•	
59,0	59,0	367	184	45,00	16	•	•	
60,0	60,0	367	184	45,00	16	•	•	

Пример заказа: STR101001 d4,0
Выберите нужный размер и добавьте после артикула.

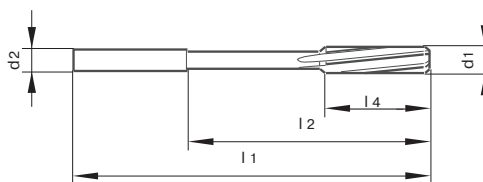

Система обозначений	
d1	диаметр режущей части, мм
d2	диаметр хвостовика, мм
L1	общая длина, мм
L2	длина обниженной части, мм
L4	длина рабочей части, мм
Z	кол-во зубьев

Все размеры указаны в мм



Группы обрабатываемых материалов Основное применение	P	•	•	•				
	M	○	○	•				
	K	•	•	•				
	N	•	•	•				
	S	○	○	○				
Точность хвостовика		h6	h6	h6				
Покрытие		BR	BR	TiN				
Стандарт		DIN 212	DIN 212	DIN 212				
d1, mm	d2, mm	L1, mm	L2, mm	L4, mm	Z	STR210000	STR210001	STR210005
1	1	34	15	5,5	3	•		
1,01	1	34	15	5,5	3	•		
1,1	1	36	15	6,5	3		•	
1,2	2	38	16	8	3		•	
1,3	2	38	16	8	3		•	
1,4	2	40	18	8	3		•	
1,5	2	40	18	8	3	•	•	
1,51	2	43	20	9	3	•		
1,53	2	43	20	9	3	•		
1,6	2	43	20	9	3		•	
1,7	2	43	20	9	3		•	
1,8	2	46	22	10	4		•	
1,97	2	49	24	11	4	•		
1,98	2	49	24	11	4	•		
1,99	2	49	24	11	4	•		
2	2	49	24	11	4	•	•	
2,01	2	49	24	11	4	•		
2,02	2	49	24	11	4	•		
2,03	2	49	24	11	4	•		
2,1	2	49	24	11	4		•	
2,2	3	53	25	12	4		•	
2,3	3	53	25	12	4		•	
2,4	3	57	29	14	4		•	
2,47	3	57	29	14	4	•		
2,49	3	57	29	14	4	•		
2,5	3	57	29	14	4	•	•	
2,51	3	57	29	14	4	•		
2,52	3	57	29	14	4	•		
2,53	3	57	29	14	4	•		

Развертки с цилиндрическим хвостовиком (h6) предназначены для использования в станках с ЧПУ. Достигается более точный и стабильный процесс изготовления отверстий, при зажиме инструмента в термо- или гидропатронах.

d1 ≤ 3,75 мм с внешними центрами на обоих концах
d1 > 3,75 мм с внутренними центрами на обоих концах

Пример заказа: STR210000 d7,97
Выберите нужный размер до 0,01 и добавьте после артикула.

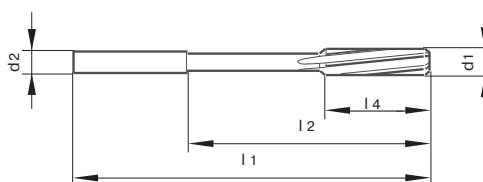

Система обозначений	
d1	диаметр режущей части, мм
d2	диаметр хвостовика, мм
L1	общая длина, мм
L2	длина обнуженной части, мм
L4	длина рабочей части, мм
Z	кол-во зубьев

Все размеры указаны в мм



Группы обрабатываемых материалов Основное применение	P	•	•	•				
	M	○	○	•				
	K	•	•	•				
	N	•	•	•				
	S	○	○	○				
Точность хвостовика		h6	h6	h6				
Покрытие		BR	BR	TIN				
Стандарт		DIN 212	DIN 212	DIN 212				
d1, mm	d2, mm	L1, mm	L2, mm	L4, mm	Z	STR210000	STR210001	STR210005
2,6	3	57	29	14	4		•	
2,7	3	61	33	15	6		•	
2,8	3	61	33	15	6		•	
2,9	3	61	33	15	6		•	
2,97	3	61	33	15	6	•		
2,98	3	61	33	15	6	•		
2,99	3	61	33	15	6	•		
3	3	61	33	15	6	•	•	•
3,01	4	65	37	16	6	•		
3,02	4	65	37	16	6	•		
3,03	4	65	37	16	6	•		
3,1	4	65	37	16	6		•	
3,2	4	65	37	16	6		•	
3,3	4	65	37	16	6		•	
3,5	4	70	42	18	6		•	•
3,6	4	70	42	18	6		•	
3,7	4	70	42	18	6		•	
3,8	4	75	47	19	6		•	
3,9	4	75	47	19	6		•	
3,97	4	75	47	19	6	•		
3,98	4	75	47	19	6	•		
3,99	4	75	47	19	6	•		
4	4	75	47	19	6	•	•	•
4,01	4	75	47	19	6	•		
4,02	4	75	47	19	6	•		
4,03	4	75	47	19	6	•		
4,1	4	75	47	19	6		•	
4,2	4	75	47	19	6		•	
4,5	5	80	52	21	6		•	•

Развертки с цилиндрическим хвостовиком (h6) предназначены для использования в станках с ЧПУ. Достигается более точный и стабильный процесс изготовления отверстий, при зажиме инструмента в термо- или гидروطронах.

d1 ≤ 3,75 мм с внешними центрами на обоих концах
d1 > 3,75 мм с внутренними центрами на обоих концах

Пример заказа: STR210000 d7,97
Выберите нужный размер до 0,01 и добавьте после артикула.



УНИВЕРСАЛЬНОЕ ПРИМЕНЕНИЕ

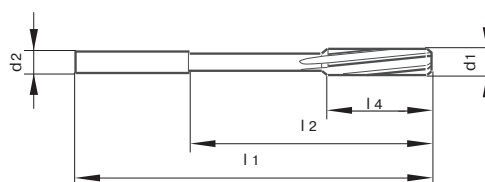

Система обозначений	
d1	диаметр режущей части, мм
d2	диаметр хвостовика, мм
L1	общая длина, мм
L2	длина обнуженной части, мм
L4	длина рабочей части, мм
Z	кол-во зубьев

Все размеры указаны в мм



Группы обрабатываемых материалов Основное применение	P	•	•	•				
	M	○	○	•				
	K	•	•	•				
	N	•	•	•				
	S	○	○	○				
Точность хвостовика		h6	h6	h6				
Покрытие		BR	BR	TIN				
Стандарт		DIN 212	DIN 212	DIN 212				
d1, mm	d2, mm	L1, mm	L2, mm	L4, mm	Z	STR210000	STR210001	STR210005
4,7	5	80	52	21	6		•	
4,8	5	86	58	23	6		•	
4,9	5	86	58	23	6		•	
4,98	5	86	58	23	6	•		
4,99	5	86	58	23	6	•		
5	5	86	58	23	6	•	•	•
5,01	5	86	58	23	6	•		
5,02	5	86	58	23	6	•		
5,03	5	86	58	23	6	•		
5,1	5	86	58	23	6		•	
5,2	5	86	58	23	6		•	
5,3	5	86	58	23	6		•	
5,4	6	93	57	26	6		•	
5,5	6	93	57	26	6		•	•
5,6	6	93	57	26	6		•	
5,7	6	93	57	26	6		•	
5,8	6	93	57	26	6		•	
5,9	6	93	57	26	6		•	
5,98	6	93	57	26	6	•		
5,99	6	93	57	26	6	•		
6	6	93	57	26	6	•	•	•
6,01	6	101	65	28	6	•		
6,02	6	101	65	28	6	•		
6,03	6	101	65	28	6	•		
6,1	6	101	65	28	6		•	
6,2	6	101	65	28	6		•	
6,3	6	101	65	28	6		•	
6,4	6	101	65	28	6		•	
6,5	6	101	65	28	6		•	•

Развертки с цилиндрическим хвостовиком (h6) предназначены для использования в станках с ЧПУ. Достигается более точный и стабильный процесс изготовления отверстий, при зажиме инструмента в термо- или гидروطронах.

d1 ≤ 3,75 мм с внешними центрами на обоих концах
d1 > 3,75 мм с внутренними центрами на обоих концах

Пример заказа: STR210000 d7,97
Выберите нужный размер до 0,01 и добавьте после артикула.

развертки

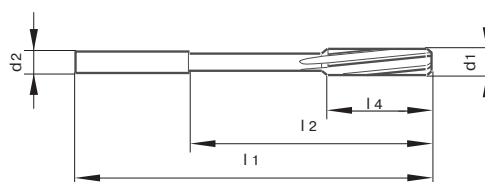

Система обозначений	
d1	диаметр режущей части, мм
d2	диаметр хвостовика, мм
L1	общая длина, мм
L2	длина обнуженной части, мм
L4	длина рабочей части, мм
Z	кол-во зубьев

Все размеры указаны в мм



Группы обрабатываемых материалов Основное применение	P	•	•	•				
	M	○	○	•				
	K	•	•	•				
	N	•	•	•				
	S	○	○	○				
Точность хвостовика		h6	h6	h6				
Покрытие		BR	BR	TIN				
Стандарт		DIN 212	DIN 212	DIN 212				
d1, mm	d2, mm	L1, mm	L2, mm	L4, mm	Z	STR210000	STR210001	STR210005
6,6	6	101	65	28	6		•	
6,8	8	109	73	31	6		•	
6,9	8	109	73	31	6		•	
7	8	109	73	31	6		•	•
7,1	8	109	73	31	6		•	
7,3	8	109	73	31	6		•	
7,4	8	109	73	31	6		•	
7,5	8	109	73	31	6		•	
7,6	8	117	81	33	6		•	
7,7	8	117	81	33	6		•	
7,8	8	117	81	33	6		•	
7,9	8	117	81	33	6		•	
7,97	8	117	81	33	6	•		
7,98	8	117	81	33	6	•		
7,99	8	117	81	33	6	•		
8	8	117	81	33	6	•	•	•
8,01	8	117	81	33	6	•		
8,02	8	117	81	33	6	•		
8,03	8	117	81	33	6	•		
8,1	8	117	81	33	6		•	
8,2	8	117	81	33	6		•	
8,3	8	117	81	33	6		•	
8,5	8	117	81	33	6		•	
8,6	10	125	85	36	6		•	
8,7	10	125	85	36	6		•	
8,8	10	125	85	36	6		•	
9	10	125	85	36	6	•	•	•
9,01	10	125	85	36	6	•		
9,1	10	125	85	36	6		•	
9,2	10	125	85	36	6		•	

Развертки с цилиндрическим хвостовиком (h6) предназначены для использования в станках с ЧПУ. Достигается более точный и стабильный процесс изготовления отверстий, при зажиме инструмента в термо- или гидроратронах.

d1 ≤ 3,75 мм с внешними центрами на обоих концах
d1 > 3,75 мм с внутренними центрами на обоих концах

Пример заказа: STR210000 d7,97
Выберите нужный размер до 0,01 и добавьте после артикула.

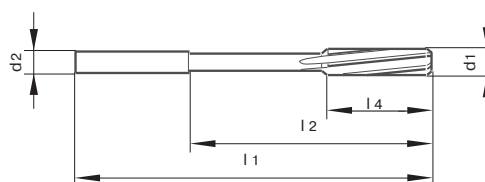

Система обозначений	
d1	диаметр режущей части, мм
d2	диаметр хвостовика, мм
L1	общая длина, мм
L2	длина обнуженной части, мм
L4	длина рабочей части, мм
Z	кол-во зубьев

Все размеры указаны в мм



Группы обрабатываемых материалов Основное применение	P	•	•	•				
	M	○	○	•				
	K	•	•	•				
	N	•	•	•				
	S	○	○	○				
Точность хвостовика		h6	h6	h6				
Покрытие		BR	BR	TIN				
Стандарт		DIN 212	DIN 212	DIN 212				
d1, mm	d2, mm	L1, mm	L2, mm	L4, mm	Z	STR210000	STR210001	STR210005
9,3	10	125	85	36	6		•	
9,5	10	125	85	36	6		•	
9,7	10	133	93	38	6		•	
9,97	10	133	93	38	6	•		
9,98	10	133	93	38	6	•		
9,99	10	133	93	38	6	•		
10	10	133	93	38	6	•	•	•
10,01	10	133	93	38	6	•		
10,02	10	133	93	38	6	•		
10,03	10	133	93	38	6	•		
11	10	142	102	41	6		•	•
11,98	10	151	111	44	6	•		
11,99	10	151	111	44	6	•		
12	10	151	111	44	6	•	•	•
12,01	10	151	111	44	6	•		
12,02	10	151	111	44	6	•		
13	10	151	111	44	6		•	•
14	14	160	115	47	8		•	•
15	14	162	117	50	8		•	•
16	14	170	125	52	8		•	•
17	14	175	130	54	8		•	•
18	14	182	137	56	8		•	•
19	16	189	141	58	8		•	•
20	16	195	147	60	8		•	•

Развертки с цилиндрическим хвостовиком (h6) предназначены для использования в станках с ЧПУ. Достигается более точный и стабильный процесс изготовления отверстий, при зажиме инструмента в термо- или гидروطроне.

d1 ≤ 3,75 мм с внешними центрами на обоих концах
d1 > 3,75 мм с внутренними центрами на обоих концах

Пример заказа: STR210000 d7,97
Выберите нужный размер до 0,01 и добавьте после артикула.

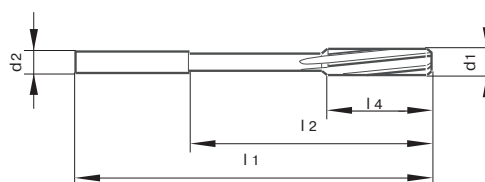

Система обозначений	
d1	диаметр режущей части, мм
d2	диаметр хвостовика, мм
L1	общая длина, мм
L2	длина обнуженной части, мм
L4	длина рабочей части, мм
Z	кол-во зубьев

Все размеры указаны в мм



Группы обрабатываемых материалов Основное применение	P	○	●				
	M	○	○				
	K	●	●				
	N	●	●				
	S	○	○				
Точность хвостовика	h6		h6				
Покрытие	BR		BR				
Стандарт	DIN 212		DIN 212				
d, mm	d2, mm	L, mm	l2, mm	l4, mm	Z	STR211000	STR210003
1	1	34	15	5,5	3	●	●
1,2	1,2	38	16,5	7,5	3	●	●
1,3	1,3	38	16,5	7,5	3		●
1,4	1,4	40	18	8	3		●
1,5	1,5	40	18	8	3	●	●
1,6	1,6	43	20	9	3	●	●
1,8	1,8	46	22	10	4	●	●
1,9	1,9	46	22	10	4		●
2	2	49	24	11	4	●	●
2,2	2,2	53	25	12	4	●	●
2,3	2,3	53	25	12	4		●
2,5	2,5	57	29	14	4	●	●
2,7	2,8	61	33	15	6		●
2,8	2,8	61	33	15	6		●
2,9	3	61	33	15	6		●
3	3	61	33	15	6	●	●
3,2	3,2	65	37	16	6	●	●
3,5	3,5	70	42	18	6	●	●
3,7	3,5	70	42	18	6		●
5,5	5,6	93	57	26	6		

d1 ≤ 3,75 мм с внешними центрами на обоих концах
 d1 > 3,75 мм с внутренними центрами на обоих концах

Пример заказа: STR211000 d2,0
 Выберите нужный размер и добавьте после артикула.



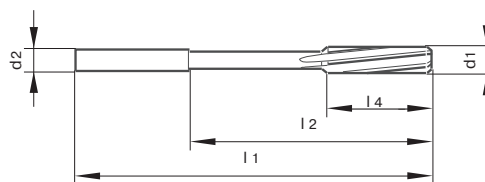

Система обозначений	
d1	диаметр режущей части, мм
d2	диаметр хвостовика, мм
L1	общая длина, мм
L2	длина обнуженной части, мм
L4	длина рабочей части, мм
Z	кол-во зубьев

Все размеры указаны в мм



Группы обрабатываемых материалов Основное применение	P	•	•	•	•	•	•	•				
	M	○	○	○	○	○	○	○				
	K	•	•	•	•	•	•	•				
	N	•	•	•	•	•	•	•				
	S	○	○	○	○	○	○	○				
Точность хвостовика		h6	h6	h9	h9	h9	h9	h9				
Покрытие		BR	BR	BR	BR	TIN	BR	BR				
Стандарт		DIN212	DIN212	DIN212	DIN212	DIN212	DIN212	DIN212				
d, mm	d2, mm	L1, mm	L2, mm	L4, mm	z	STR211001	STR210002	STR211011	STR210012	STR210006	STR210018	STR210019
1,0	1,0	34	15	5,5	3			•	•			
1,1	1,1	36	15,5	6,5	3			•	•			
1,2	1,2	38	16,5	7,5	3			•	•			
1,3	1,3	38	16,5	7,5	3			•	•			
1,4	1,4	40	18	8	3			•	•			
1,5	1,5	40	18	8	3			•	•			
1,6	1,6	43	20	9	3			•	•			
1,8	1,8	46	22	10	4			•	•			
2,0	2,0	49	24	11	4			•	•			
2,0	2,0	65	45	11	4						•	
2,2	2,2	53	25	12	4			•	•			
2,5	2,5	57	29	14	4			•	•			
2,5	2,5	75	55	14	4						•	
2,8	2,8	61	33	15	6			•	•			
3,0	3,0	61	33	15	6			•	•	•		
3,0	3,0	90	65	15	6						•	
3,2	3,2	65	37	16	6			•	•			
3,5	3,5	70	42	18	6			•	•	•		
3,5	3,5	90	65	18	6						•	
3,8	4,0	75	47	19	6			•	•			
4,0	4,0	75	47	19	6	•	•	•	•	•		
4,0	4,0	105	70	19	6						•	
4,4	4,5	80	52	21	6			•	•			
4,5	4,5	80	52	21	6	•	•			•		
4,5	4,5	105	70	21	6						•	
4,7	4,5	80	52	21	6			•	•			
4,9	5,0	86	58	23	6			•	•			
5,0	5,0	86	58	23	6	•	•	•	•	•		
5,0	5,0	115	80	23	6						•	
5,1	5	86	58	23	6			•	•			
5,5	5,6	93	57	26	6	•	•	•	•	•		
5,5	5,5	115	80	26	6						•	
6,0	5,6	93	57	26	6	•	•	•	•	•		
6,0	6,0	130	90	26	6						•	

d1 ≤ 3,75 мм с внешними центрами на обоих концах
d1 > 3,75 мм с внутренними центрами на обоих концах

Пример заказа: STR211001 d8,0
Выберите нужный размер и добавьте после артикула.

развертки

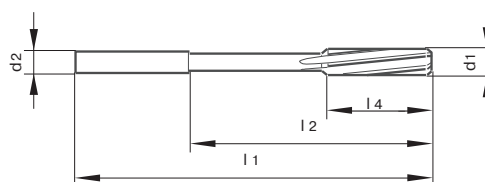

Система обозначений	
d1	диаметр режущей части, мм
d2	диаметр хвостовика, мм
L1	общая длина, мм
L2	длина обнуженной части, мм
L4	длина рабочей части, мм
Z	кол-во зубьев

Все размеры указаны в мм



Группы обрабатываемых материалов Основное применение	P	•	•	•	•	•	•						
	M	○	○	○	○	○	○						
Точность хвостовика	K	•	•	•	•	•	•						
	N	•	•	•	•	•	•						
Покрытие	S	○	○	○	○	○	○						
		BR	BR	BR	BR	TIN	BR	BR					
Стандарт		DIN212	DIN212	DIN212	DIN212	DIN212	DIN212	DIN212					
	d, mm	d2, mm	L1, mm	L2, mm	L4, mm	z	STR211001	STR210002	STR211011	STR210012	STR210006	STR210018	STR210019
6,0	6,0	250	210	26	6								•
6,1	6,3	101	65	28	6			•					
6,2	6,3	101	65	28	6			•					
6,5	6,3	101	65	28	6			•			•		
6,5	6,0	130	90	28	6							•	
7,0	7,1	109	73	31	6	•		•		•			
7,0	7,0	140	95	31	6							•	
7,1	7,1	109	73	31	6			•					
7,2	7,1	109	73	31	6			•					
7,5	7,1	109	73	31	6			•					
7,5	7,0	140	95	31	6							•	
8,0	8,0	117	81	33	6	•		•		•			
8,0	8,0	160	115	33	6							•	
8,0	8,0	250	205	33	6								•
8,1	8,0	117	81	33	6			•					
8,3	8,0	117	81	33	6			•					
8,5	8,0	117	81	33	6	•		•					
8,5	8,0	160	115	33	6							•	
9,0	9,0	125	85	36	6	•		•		•			
9,0	9,0	175	130	36	6							•	
9,2	9,0	125	85	36	6			•					
9,4	9,0	125	85	36	6			•					
9,5	9,0	125	85	36	6	•		•					
9,5	9,0	175	130	36	6							•	
9,9	10,0	133	93	38	6			•					
10,0	10,0	133	93	38	6	•		•		•			
10,0	10,0	190	140	38	6							•	
10,0	10,0	250	200	38	6								•
10,1	10,0	133	93	38	6			•					
10,5	10,0	133	93	38	6	•							
10,7	10,0	142	102	41	6			•					
11,0	10,0	142	102	41	6	•		•		•			
11,0	10,0	200	150	41	6							•	
11,5	10,0	142	102	41	6	•		•					

d1 ≤ 3,75 мм с внешними центрами на обоих концах
d1 > 3,75 мм с внутренними центрами на обоих концах

Пример заказа: STR211001 d8,0
Выберите нужный размер и добавьте после артикула.

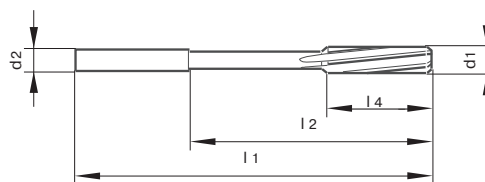

Система обозначений	
d1	диаметр режущей части, мм
d2	диаметр хвостовика, мм
L1	общая длина, мм
L2	длина обниженной части, мм
L4	длина рабочей части, мм
Z	кол-во зубьев

Все размеры указаны в мм



Группы обрабатываемых материалов Основное применение	P	•	•	•	•	•	•	•				
	M	○	○	○	○	○	○	○				
	K	•	•	•	•	•	•	•				
	N	•	•	•	•	•	•	•				
	S	○	○	○	○	○	○	○				
Точность хвостовика		h6	h6	h9	h9	h9	h9	h9				
Покрытие		BR	BR	BR	BR	TIN	BR	BR				
Стандарт		DIN212	DIN212	DIN212	DIN212	DIN212	DIN212	DIN212				
d, mm	d2, mm	L1, mm	L2, mm	L4, mm	z	STR211001	STR210002	STR211011	STR210012	STR210006	STR210018	STR210019
12,0	10,0	151	111	44	6	•	•	•	•	•		
12,0	12,0	210	160	44	6						•	
13,0	10,0	151	111	44	6	•	•	•	•	•		
14,0	12,5	160	115	47	8	•	•	•	•	•		
15,0	12,5	162	117	50	8	•	•	•	•	•		
16,0	12,5	170	125	52	8	•	•	•	•	•		
17,0	14,0	175	130	54	8	•	•	•	•	•		
18,0	14,0	182	137	56	8	•	•	•	•	•		
19,0	16,0	189	141	58	8	•	•	•	•	•		
20,0	16,0	195	147	60	8	•	•	•	•	•		
21,0	18,0	215	159	55	8			•	•			
22,0	18,0	225	162	55	8			•	•			
23,0	18,0	230	167	60	8			•	•			
24,0	20,0	240	177	60	10			•	•			
25,0	20,0	245	182	60	10			•	•			
26,0	20,0	250	180	60	10			•	•			
27,0	22,0	260	190	60	10			•	•			
28,0	22,0	270	200	65	10			•	•			
29,0	22,0	270	200	65	10			•	•			
30,0	24,0	280	200	70	10			•	•			
31,0	24,0	290	210	70	10			•	•			
32,0	24,0	290	210	70	10			•	•			

d1 ≤ 3,75 мм с внешними центрами на обоих концах
 d1 > 3,75 мм с внутренними центрами на обоих концах

Пример заказа: STR211001 d8,0
 Выберите нужный размер и добавьте после артикула.

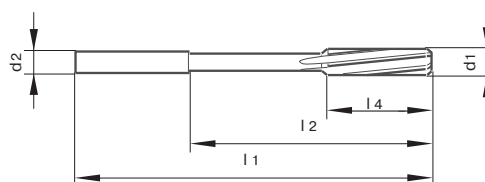

Система обозначений	
d1	диаметр режущей части, мм
d2	диаметр хвостовика, мм
L1	общая длина, мм
L2	длина обнуженной части, мм
L4	длина рабочей части, мм
Z	кол-во зубьев

Все размеры указаны в мм



Группы обрабатываемых материалов Основное применение	P	•	•				
	M	○	○	○			
K	•	•	•				
N	•	•	•				
S	○	○	○				
Точность хвостовика		h9	h6				
Покрытие		BR	BR				
Стандарт		DIN212	DIN212				
d, mm	d2, mm	L, mm	l2, mm	l4, mm	Z	STR210007	STR210004
0,95-1,06	1,0	34	15	5,5	3	•	•
1,07-1,18	1,1	36	15,5	6,5	3	•	
1,07-1,18	1,0	36	15,5	6,5	3		•
1,19-1,32	1,2	38	16,5	7,5	3	•	
1,19-1,32	2,0	38	16,5	8	3		•
1,33-1,41	1,4	40	18	8	3	•	
1,42-1,5	1,5	40	18	8	3	•	
1,33-1,50	2,0	40	18	8	3		•
1,51-1,70	1,6	43	20	9	3	•	
1,51-1,70	2,0	43	20	9	4		•
1,71-1,90	1,8	46	22	10	4	•	
1,71-1,90	2,0	46	22	10	4		•
1,91-2,12	2,0	49	24	11	4	•	•
2,13-2,36	2,2	53	25	12	4	•	
2,13-2,36	3,0	53	25	12	4		•
2,37-2,65	2,5	57	29	14	4	•	
2,37-2,65	3,0	57	29	14	4		•
2,66-2,79	3,0	61	33	15	4		•
2,66-2,80	2,8	61	33	15	6	•	
2,80-3,00	3,0	61	33	15	6	•	•
3,01-3,35	3,2	65	37	16	6	•	
3,01-3,35	4,0	65	37	16	6		•
3,36-3,75	3,5	70	42	18	6	•	
3,36-3,75	4,0	70	42	18	6		•
3,76-4,25	4,0	75	47	19	6	•	•
4,26-4,75	4,5	80	52	21	6	•	
4,26-4,75	5,0	80	52	21	6		•
4,76-5,30	5,0	86	58	23	6	•	•
5,31-6,00	5,6	93	57	26	6	•	
5,31-6,00	6,0	93	57	26	6		•
6,01-6,70	6,3	101	65	28	6	•	
6,01-6,70	6,0	101	65	28	6		•
6,71-7,50	7,1	109	73	31	6	•	
6,71-7,50	8,0	109	73	31	6		•

Развертки с цилиндрическим хвостовиком (h6) предназначены для использования в станках с ЧПУ. Достигается более точный и стабильный процесс изготовления отверстий, при зажиме инструмента в термо- или гидроратронах.

Пример заказа: STR210007 d8,21
Выберите нужный размер до 0,01 и добавьте после артикула.

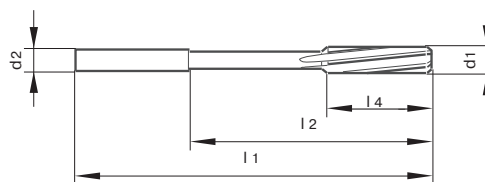

Система обозначений	
d1	диаметр режущей части, мм
d2	диаметр хвостовика, мм
L1	общая длина, мм
L2	длина обнуженной части, мм
L4	длина рабочей части, мм
Z	кол-во зубьев

Все размеры указаны в мм



Группы обрабатываемых материалов Основное применение	P	•	•				
	M	○	○				
	K	•	•				
	N	•	•				
	S	○	○				
Точность хвостовика		h9	h6				
Покрытие		BR	BR				
Стандарт		DIN212	DIN212				
d, mm	d2, mm	L, mm	L2, mm	L4, mm	Z	STR210007	STR210004
7,51 - 8,50	8,0	117	81	33	6	•	•
8,51 - 9,50	9,0	125	85	36	6	•	
8,51 - 9,50	10,0	125	85	36	6		•
9,99-10,00	10,0	133	93	38	6	•	
9,51 -10,60	10,0	133	93	38	6	•	•
10,61 -11,80	10,0	142	102	41	6	•	•
11,81-12,00	10,0	151	111	44	6	•	
12,01-12,05	10,0	151	74,5	44	6	•	
11,81 -12,25	10,0	151	111	44	6		•
12,26-13,20	10,0	151	111	44	8		•

Развертки с цилиндрическим хвостовиком (h6) предназначаются для использования в станках с ЧПУ. Достигается более точный и стабильный процесс изготовления отверстий, при зажиме инструмента в термо- или гидропатронах.

Пример заказа: STR210007 d8,21

Выберите нужный размер до 0,01 и добавьте после артикула.



УНИВЕРСАЛЬНОЕ ПРИМЕНЕНИЕ

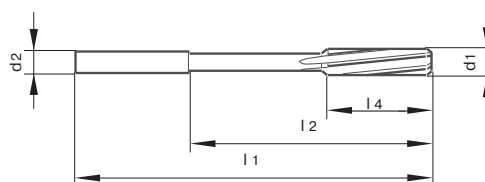

Система обозначений	
d1	диаметр режущей части, мм
d2	диаметр хвостовика, мм
L1	общая длина, мм
L2	длина обнуженной части, мм
L4	длина рабочей части, мм
Z	кол-во зубьев

Все размеры указаны в мм



Группы обрабатываемых материалов Основное применение	P	•	•			
	M	○	○			
	K	•	•			
	N	•	•			
	S	○	○			
Точность хвостовика	h8		h8			
Покрытие	BR		BR			
Стандарт	DIN 8089		DIN 8089			
d, mm	d2, mm	l, mm	l2, mm	Z	STR211016	STR210016
1,5	1,5	45	12	4	•	•
2,0	2,0	50	16	4	•	•
2,5	2,5	56	18	4	•	•
3,0	3,0	56	18	6	•	•
3,5	3,0	56	20	6	•	•
4,0	3,55	56	20	6	•	•
4,5	4,0	63	22	6	•	•
5,0	4,0	63	22	6	•	•
5,5	5,0	63	22	6	•	•
6,0	5,0	63	22	6	•	•
6,5	5,0	63	22	6	•	•
7,0	6,3	71	25	6	•	•
7,5	6,3	71	25	6	•	•
8,0	6,3	71	25	6	•	•
8,5	6,3	71	25	6	•	•
9,0	8,0	71	25	6	•	•
9,5	8,0	71	25	6	•	•
10,0	8,0	71	25	6	•	•
11,0	10,0	80	28	6	•	•
12,0	10,0	80	28	6	•	•
13,0	10,0	80	28	6	•	•
14,0	12,5	90	32	8	•	•
15,0	12,5	90	32	8	•	•
16,0	12,5	90	32	8	•	•
17,0	12,5	90	32	8	•	•
18,0	16,0	100	36	8	•	•
19,0	16,0	100	36	8	•	•
20,0	16,0	100	36	8	•	•

Пример заказа: STR210016 d8,0

Выберите нужный размер и добавьте после артикула.

развертка

СПИРАЛЬ 45°

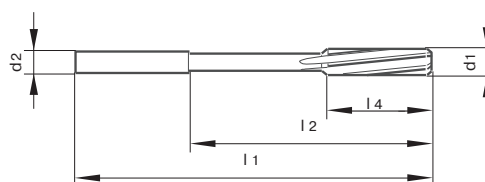

Система обозначений	
d1	диаметр режущей части, мм
d2	диаметр хвостовика, мм
L1	общая длина, мм
L2	длина обнуженной части, мм
L4	длина рабочей части, мм
Z	кол-во зубьев

Все размеры указаны в мм



Группы обрабатываемых материалов Основное применение	P	•				
	M	○				
	K	•				
	N	•				
	S	○				
Точность хвостовика	h9					
Покрытие	BR					
Стандарт	DIN 8089					
d, mm	d2, mm	L, mm	l2, mm	l4, mm	Z	STR210045
1,0	1,0	34	15	5,5	2	•
1,2	1,2	38	16,5	7,5	2	•
1,4	1,4	40	18	8	2	•
1,5	1,5	40	18	8	2	•
1,6	1,6	43	20	9	2	•
1,8	1,8	46	22	10	2	•
2	2,0	49	24	11	3	•
2,2	2,2	53	25	12	3	•
2,5	2,5	57	29	14	3	•
2,8	2,8	61	33	15	3	•
3	3,0	61	33	15	3	•
3,2	3,2	65	37	16	3	•
3,5	3,5	70	42	18	3	•
4,0	4,0	75	47	19	3	•
4,5	4,5	80	52	21	3	•
5,0	5,0	86	58	23	3	•
5,5	5,6	93	57	26	3	•
6,0	5,6	93	57	26	3	•
6,5	6,3	101	65	28	3	•
7,0	7,1	109	73	31	3	•
8,0	8,0	117	81	33	3	•
8,5	8,0	117	81	33	3	•
9,0	9,0	125	85	36	3	•
10,0	10,0	133	93	38	3	•
11,0	10,0	142	102	41	3	•
12,0	10,0	151	111	44	4	•
13,0	10,0	151	111	44	4	•
14,0	12,5	160	115	47	4	•
15,0	12,5	162	117	50	4	•
16,0	12,5	170	125	52	4	•
17,0	14,0	175	130	54	4	•
18,0	14,0	182	137	56	4	•
19,0	16,0	189	141	58	4	•
20,0	16,0	195	147	60	4	•

Данная серия с уменьшенным количеством зубьев, увеличенными канавками и спиралью в 45° градусов, позволяет достичь более высокую скорость и чистоту обрабатываемых отверстий.

d1 ≤ 3,75 мм с внешними центрами на обоих концах
d1 > 3,75 мм с внутренними центрами на обоих концах

Пример заказа: STR210045 d8,0

Выберите нужный размер и добавьте после артикула.

ХВОСТОВИК С КОНУСОМ МОРЗЕ

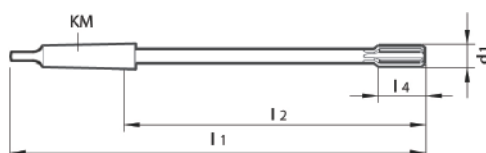

Система обозначений	
d1	диаметр режущей части, мм
d2	диаметр хвостовика, мм
L1	общая длина, мм
L2	длина обниженной части, мм
L4	длина рабочей части, мм
Z	кол-во зубьев

Все размеры указаны в мм



Группы обрабатываемых материалов Основное применение							P			
							M	K	N	S
Покрытие							BR	BR	TIN	BR
Стандарт							DIN 208	DIN 208	DIN 208	DIN 208
d, mm	l1, mm	l2, mm	l4, mm	MK	z	STR211008	STR210008	STR210009	STR210010	
3,0	112	46,5	15	1	6	•	•			
4,0	125	59,5	19	1	6	•	•			
5,0	133	67,5	23	1	6	•	•			
5,1	133	67,5	23	1	6	•	•			
5,5	138	72,5	26	1	6	•	•			
6,0	138	72,5	26	1	6	•	•	•		
6,1	144	82	28	1	6	•	•			
6,2	144	82	28	1	6	•	•			
6,5	144	82	28	1	6	•	•			
7,0	150	84,5	31	1	6	•	•	•		
7,5	150	84,5	31	1	6	•	•			
8,0	156	90,5	33	1	6	•	•	•		
8,5	156	94	33	1	6	•	•			
9,0	162	96,5	36	1	6	•	•	•		
9,5	162	96,5	36	1	6	•	•			
9,8	168	102,5	38	1	6	•	•			
10,0	168	102,5	38	1	6	•	•	•		
10,1	168	102,5	38	1	6	•	•			
11,0	175	109,5	41	1	6	•	•	•		
12,0	182	116,5	44	1	6	•	•	•		
12,0	315	245	44	1	6				•	
13,0	182	116,5	44	1	8	•	•	•		
13,0	245	179	44	1	8				•	
14,0	189	123,5	47	1	8	•	•	•		
14,0	245	179	47	1	8				•	
15,0	204	124	50	2	8	•	•	•		
15,0	260	180	50	2	8				•	
15,7	210	130	52	2	8	•	•			
16,0	210	130	52	2	8	•	•	•		
16,0	260	180	52	2	8				•	
17,0	214	134	54	2	8	•	•	•		
18,0	219	139	56	2	8	•	•	•		
18,0	260	180	56	2	8				•	
19,0	223	143	58	2	8	•	•	•		
19,5	228	148	60	2	8	•	•			
20,0	228	148	60	2	8	•	•	•		
20,0	270	190	60	2	8				•	
21,0	232	152	62	2	8	•	•			

Пример заказа: STR210010 d12,0
Выберите нужный размер и добавьте после артикула.

ХВОСТОВИК С КОНУСОМ МОРЗЕ

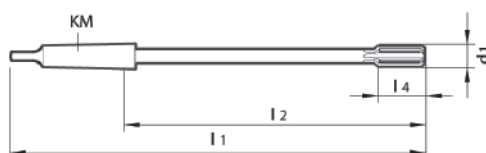

Система обозначений	
d1	диаметр режущей части, мм
d2	диаметр хвостовика, мм
L1	общая длина, мм
L2	длина обниженной части, мм
L4	длина рабочей части, мм
Z	кол-во зубьев

Все размеры указаны в мм



Группы обрабатываемых материалов Основное применение							P			
							M	K	N	S
Покрытие							BR	BR	TIN	BR
Стандарт							DIN 208	DIN 208	DIN 208	DIN 208
d, mm	l1, mm	l2, mm	l4, mm	MK	z	STR211008	STR210008	STR210009	STR210010	
22,0	237	157	64	2	8	•	•			
22,0	280	200	64	2	8				•	
23,0	241	161	66	2	8	•	•			
24,0	268	169	68	3	10	•	•			
24,0	300	220	68	3	10				•	
25,0	268	169	68	3	10	•	•			
25,0	320	220	68	3	10				•	
26,0	273	174	70	3	10	•	•			
26,0	330	230	70	3	10				•	
27,0	277	178	71	3	10	•	•			
28,0	277	178	71	3	10	•	•			
28,0	310	210	71	3	10				•	
29,0	281	182	73	3	10	•	•			
30,0	281	182	73	3	10	•	•			
30,0	350	250	73	3	10				•	
31,0	285	186	75	3	12	•	•			
32,0	317	193	77	4	12	•	•			
32,0	375	250	77	4	12				•	
33,0	317	193	77	4	12	•	•			
34,0	321	197	78	4	12	•	•			
34,0	375	250	78	4	12				•	
35,0	321	197	78	4	12	•	•			
36,0	325	201	79	4	12	•	•			
36,0	375	250	79	4	12				•	
37,0	325	201	79	4	12	•	•			
38,0	329	205	81	4	12	•	•			
38,0	395	270	81	4	12				•	
39,0	329	205	81	4	12	•	•			
40,0	329	205	81	4	12	•	•			
40,0	395	270	81	4	12				•	
41,0	333	209	82	4	12	•	•			
42,0	333	209	82	4	12	•	•			
42,0	405	280	82	4	12				•	
43,0	336	212	83	4	12	•	•			
44,0	336	212	83	4	12	•	•			
45,0	336	212	83	4	14	•	•			
45,0	405	280	83	4	14				•	
46,0	340	216	84	4	14	•	•			

Пример заказа: STR210010 d12,0
Выберите нужный размер и добавьте после артикула.

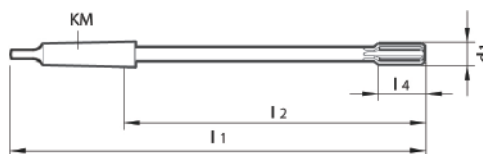

Система обозначений	
d1	диаметр режущей части, мм
d2	диаметр хвостовика, мм
L1	общая длина, мм
L2	длина обнуженной части, мм
L4	длина рабочей части, мм
Z	кол-во зубьев

Все размеры указаны в мм



Группы обрабатываемых материалов Основное применение	P	•	•	•	•				
	M	○	○	•	○				
	K	•	•	•	•				
	N	•	•	•	•				
	S	○	○	○	○				
Покрытие		BR	BR	TIN	BR				
Стандарт		DIN 208	DIN 208	DIN 208	DIN 208				
d, mm	l1, mm	l2, mm	l4, mm	MK	z	STR211008	STR210008	STR210009	STR210010
47,0	340	216	84	4	14	•	•		
48,0	344	220	86	4	14	•	•		
49,0	344	220	86	4	14	•	•		
50,0	344	220	86	4	14	•	•		
50,0	415	290	86	4	14				•
52,0	360	236	90	4	14	•	•		
53,0	360	236	90	4	14	•	•		
55,0	360	236	90	4	14	•	•		
56,0	360	236	90	4	14	•	•		
58,0	390	234	90	5	16	•	•		
60,0	390	234	90	5	16	•	•		

Пример заказа: STR210010 d12,0

Выберите нужный размер и добавьте после артикула.

СПИРАЛЬ 45°. ХВОСТОВИК С КОНУСОМ МОРЗЕ.

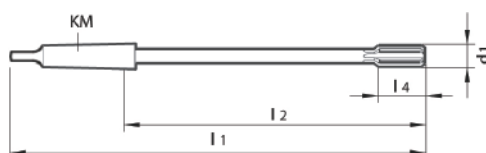

Система обозначений	
d1	диаметр режущей части, мм
d2	диаметр хвостовика, мм
L1	общая длина, мм
L2	длина обнуженной части, мм
L4	длина рабочей части, мм
Z	кол-во зубьев

Все размеры указаны в мм

Группы обрабатываемых материалов Основное применение	P	•				
	M	○				
	K	•				
	N	•				
	S	○				
Покрытие	BR					
Стандарт	DIN 208					
d, mm	l, mm	l2, mm	l4, mm	MK	z	STR210051
3,0	115	53	15	1	3	•
4,0	125	63	19	1	3	•
5,0	133	67,5	23	1	3	•
6,0	138	72,5	26	1	3	•
7,0	150	84,5	31	1	3	•
8,0	156	90,5	33	1	3	•
9,0	162	96,5	36	1	3	•
10,0	168	102,5	38	1	4	•
11,0	175	109,5	41	1	4	•
12,0	182	116,5	44	1	4	•
13,0	182	116,5	44	1	4	•
14,0	189	123,5	47	1	4	•
15,0	204	124,0	50	2	4	•
16,0	210	130,0	52	2	4	•
17,0	214	134,0	54	2	4	•
18,0	219	139,0	56	2	4	•
19,0	223	143,0	58	2	4	•
20,0	228	148,0	60	2	4	•
21,0	232	152,0	62	2	4	•
22,0	237	157,0	64	2	4	•
23,0	241	161,0	66	2	4	•
24,0	268	169,0	68	3	4	•
25,0	268	169,0	68	3	4	•
26,0	273	174,0	70	3	6	•
27,0	277	178,0	71	3	6	•
28,0	277	178,0	71	3	6	•
29,0	281	182,0	73	3	6	•
30,0	281	182,0	73	3	6	•
31,0	285	186,0	75	3	6	•
32,0	317	218,0	77	4	6	•

Данная серия с уменьшенным количеством зубьев, спиралью в 45° градусов и увеличенными канавками, позволяет достичь более высокую скорость и чистоту обрабатываемых отверстий.

d1 ≤ 3,00 мм со стороны реж. части с внешним центром, со стороны хвостовика с внутренним центром.
d1 > 4,00 мм по стандарту.

Пример заказа: STR210045 d8,0

Выберите нужный размер и добавьте после артикула.



УНИВЕРСАЛЬНОЕ ПРИМЕНЕНИЕ

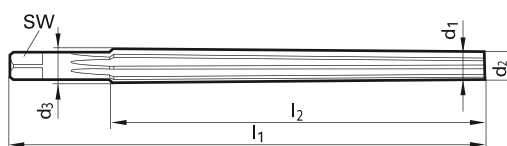
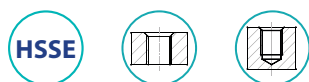

Система обозначений	
d	номинальный диаметр, мм
d2	диаметр малый, мм
d3	диаметр большой, мм
l1	общая длина, мм
l2	длина рабочей части, мм
SW	квадрат хвостовика, мм
Z	кол-во зубьев



Группы обрабатываемых материалов Основное применение	P											
	M	K	N	S								
Конусность	1:50	1:50	1:10	1:10	1:20	1:100						
Покрытие	(BR)	(BR)	(BR)	(BR)	(BR)	(BR)						
Стандарт	DIN 9	DIN 9	OCT	OCT	OCT	OCT						
d, mm	d2, mm	d3, mm	l, mm	l2mm	SW	z	STR101060	STR101061	STR101070	STR100070	STR100080	STR101090
1,0	0,90	1,46	46	28	2,50	3	•	•				
1,5	1,40	2,14	57	37	2,50	3	•	•				
1,5	1,40	1,77	62	37	1,25	4						•
1,6	1,50	2,24	57	37	2,50	4	•	•				
1,75	1,65	2,08	68	45	1,60	4						•
2,0	1,90	2,38	73	48	1,80	4						•
2,0	1,90	2,86	68	48	2,50	4	•	•				
-	2,00	5,00	85	60	4,00	4				•		
2,25	2,15	2,66	77	51	2,00	4						•
2,5	2,40	3,36	68	48	2,50	4	•	•				
2,5	2,40	2,93	80	53	2,24	4						•
-	2,50	5,50	85	60	4,50	4					•	
3,0	2,90	4,06	80	58	3,15	5	•	•				
3,0	2,90	3,53	91	63	2,80	6						•
-	3,00	10,00	100	70	6,30	5			•			
-	3,00	7,00	110	80	5,60	5					•	
3,5	3,40	4,90	100	75	3,55	5	•	•				
3,5	3,40	4,09	96	69	3,15	6						•
-	3,50	7,50	110	80	6,30	5					•	
4,0	3,90	5,26	93	68	4,00	5	•	•				
4,0	3,90	4,65	100	75	3,15	6						•
-	4,00	8,00	120	80	6,30	5					•	
4,5	4,40	6,14	115	87	4,50	5	•	•				
4,5	4,40	5,21	108	81	4,00	6						•
-	4,50	9,00	130	90	7,10	6					•	
5,0	4,90	6,36	100	73	5,00	5	•	•				
5,0	4,90	5,77	115	87	4,50	6						•
-	5,00	15,00	140	100	10,00	5			•			
-	5,00	9,50	130	90	8,00	6					•	
5,5	5,40	7,78	150	119	5,60	6	•	•				
5,5	5,40	6,43	133	103	5,00	6						•
-	5,50	10,00	130	90	8,00	6					•	
6,0	5,90	8,00	135	105	6,30	6	•	•				
6,0	5,90	7,09	150	119	5,60	6						•
-	6,00	11,00	140	100	9,00	6					•	
6,5	6,40	8,78	150	119	6,30	6	•	•				
7,0	6,90	8,20	164	130	6,30	6						•
7,0	6,90	9,72	177	141	7,10	6	•	•				
-	7,00	12,00	140	100	10,00	6					•	



УНИВЕРСАЛЬНОЕ ПРИМЕНЕНИЕ

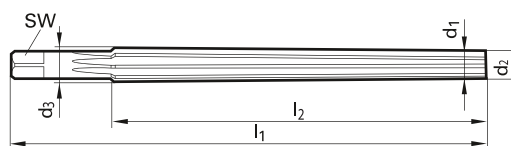
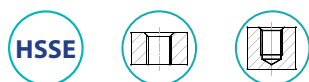

Система обозначений	
d	номинальный диаметр, мм
d2	диаметр малый, мм
d3	диаметр большой, мм
l1	общая длина, мм
l2	длина рабочей части, мм
SW	квадрат хвостовика, мм
Z	кол-во зубьев



Группы обрабатываемых материалов Основное применение	P	•	•	•	•	•	•					
	M	○	○	○	○	○	○					
	K	•	•	•	•	•	•					
	N	•	•	•	•	•	•					
	S	○	○	○	○	○	○					
Конусность		1:50	1:50	1:10	1:10	1:20	1:100					
Покрытие		(BR)	(BR)	(BR)	(BR)	(BR)	(BR)					
Стандарт		DIN 9	DIN 9	OCT	OCT	OCT	OCT					
d, mm	d2, mm	d3, mm	l1, mm	l2, mm	SW	z	STR101060	STR101061	STR101070	STR100070	STR100080	STR101090
8,0	7,90	9,31	177	141	7,10	6						•
8,0	7,90	10,80	180	145	8,00	6	•	•				
-	8,00	14,00	165	120	11,20	6					•	
9,0	8,90	12,16	205	163	9,00	6	•	•				
9,0	8,90	10,42	190	152	8,00	6						•
-	9,00	15,00	165	120	11,20	8					•	
10,0	9,90	13,40	215	175	10,00	6	•	•				
10,0	9,90	11,53	205	163	9,00	8						•
-	10,00	25,00	195	150	16,00	7			•	•		
-	10,00	16,00	165	120	12,50	8					•	
11,0	10,90	12,63	216	173	10,00	8						•
12,0	11,80	16,00	255	210	11,20	8	•	•				
12,5	12,40	14,29	234	189	11,20	8						•
13,0	12,86	16,74	240	194	12,50	8	•	•				
14,0	13,86	17,74	240	194	12,50	8	•	•				
14,0	13,90	15,97	257	207	12,50	8						•
-	15,00	35,00	250	200	22,40	9			•	•		
16,0	15,80	20,40	280	230	14,00	8	•	•				
16,0	15,90	18,24	290	234	12,50	8						•
18,0	17,90	20,42	325	252	14,00	8						•
20,0	19,80	22,50	340	270	16,00	8						•
20,0	19,80	24,80	310	250	18,00	10	•	•				
-	23,00	45,00	275	220	31,50	11			•	•		
25,0	24,70	30,70	370	300	22,40	10	•	•				
30,0	29,70	36,10	400	320	25,00	12	•	•				
-	30,00	55,00	310	250	40,00	13			•	•		
-	37,00	65,00	345	280	45,00	15			•	•		
40,0	39,70	46,50	430	340	31,50	12	•	•				
-	45,00	75,00	370	300	45,00	17			•	•		
50,0	49,70	56,90	460	360	40,00	14	•	•				

развертки

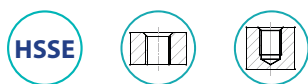

Система обозначений	
d	номинальный диаметр, мм
d2	диаметр малый, мм
d3	диаметр большой, мм
l1	общая длина, мм
l2	длина рабочей части, мм
SW	квадрат хвостовика, мм
Z	кол-во зубьев

Группы обрабатываемых материалов Основное применение	P	•					
	M	○					
	K	•					
	N	•					
	S	○					
Конусность	1:50						
Точность хвостовика	h9						
Покрытие	BR						
Стандарт	DIN 2179						
d, mm	d2 mm	d3 mm	l, mm	l2mm	d4mm	z	STR210065
1,0	0,90	1,46	60	33	1,40	2	•
1,5	1,40	2,26	64	43	2,00	2	•
2,0	1,90	2,86	86	48	3,15	2	•
2,5	2,40	3,36	86	48	3,15	3	•
3,0	2,90	4,06	100	58	4,00	3	•
4,0	3,90	5,26	112	68	5,00	3	•
5,0	4,90	6,36	122	73	6,30	3	•
6,0	5,90	8,00	160	105	8,00	3	•
6,5	6,40	8,78	187	119	8,50	3	•
8,0	7,90	10,80	207	145	10,00	3	•
10,0	9,90	13,40	245	175	12,50	3	•
12,0	11,80	16,00	290	210	16,00	3	•
13,0	12,86	16,74	275	194	16,00	3	•
14,0	13,86	17,74	275	194	17,00	3	•
16,0	15,84	21,12	355	264	20,00	3	•
20,0	19,80	25,20	370	270	24,00	3	•
25,0	24,74	30,94	420	310	28,00	4	•
30,0	29,70	36,10	475	320	35,00	4	•

Развертки с конусностью 1:50 - для отверстий под конические шпильки, для предварительной обработки отверстий рекомендуем использовать конические сверла.

d1 ≤ 4,00 мм с цельной вершиной на обоих концах
 d1 > 4,00 мм с внутренними центрами на обоих концах
 d1 ≤ 1,50 мм заводской стандарт.

Пример заказа: STR210065 d8,0
 Выберите нужный размер и добавьте после артикула.



УНИВЕРСАЛЬНОЕ ПРИМЕНЕНИЕ



Система обозначений	
d	номинальный диаметр, мм
d2	диаметр малый, мм
d3	диаметр большой, мм
l1	общая длина, мм
l2	длина рабочей части, мм
SW	квадрат хвостовика, мм
Z	кол-во зубьев



Группы обрабатываемых материалов Основное применение	P	•	•	•	•					
	M	○	•	○	○					
	K	•	•	•	•					
	N	•	•	•	•					
	S	○	•	○	○					
Конусность		1:50	1:50	1:50	1:50					
Покрытие		(BR)	(BR)	(BR)	(BR)					
Стандарт		DIN 2180	DIN 2180	DIN 9	DIN 9					
d, mm	d2 mm	d3 mm	l, mm	l2mm	MK	z	STR110013	STR110012	STR101050	STR100050
4,0	3,90	5,40	170	75	1	3	•			
5,0	4,90	6,36	155	73	1	3	•	•		
6,0	5,90	8,00	187	105	1	3	•	•		
6,5	6,40	8,78	205	119	1	3	•			
8,0	7,90	10,80	227	145	1	3	•	•		
8,0	7,90	10,80	227	145	1	6			•	•
10,0	9,90	13,40	257	175	1	3	•	•		
10,0	9,90	13,40	257	175	1	6			•	•
12,0	11,80	16,00	315	210	2	3	•	•		
12,0	11,80	16,00	315	210	2	8			•	•
13,0	12,80	16,74	300	194	2	3	•	•		
13,0	12,86	16,74	295	194	2	8			•	•
14,0	13,80	17,74	300	194	2	3	•	•		
14,0	13,86	17,74	295	194	2	8			•	•
16,0	15,80	20,40	335	230	2	3	•	•		
16,0	15,80	20,40	335	230	2	8			•	•
20,0	19,80	24,80	377	250	3	3	•	•		
20,0	19,80	24,80	377	250	3	10			•	•
25,0	24,70	30,70	427	300	3	4	•	•		
25,0	24,70	30,70	427	300	3	10			•	•
30,0	29,70	36,10	475	320	4	6	•	•		
30,0	29,70	36,10	475	320	4	12			•	•
40,0	39,70	46,50	495	340	4	8	•	•		
40,0	39,70	46,50	495	340	4	12			•	•
50,0	49,70	56,90	550	360	5	8	•	•		
50,0	49,70	56,90	550	360	5	12			•	•

Развертки с конусностью 1:50 - для отверстий под конические шпильки, для предварительной обработки отверстий рекомендуем использовать конические сверла.

Пример заказа: STR110012 d8,0

Выберите нужный размер и добавьте после артикула.

развертки



Система обозначений	
d1	диаметр режущей части, мм
d2	диаметр хвостовика, мм
L1	общая длина, мм
L2	длина обнуженной части, мм
L4	длина рабочей части, мм
Z	кол-во зубьев

Все размеры указаны в мм

Группы обрабатываемых материалов Основное применение	P	•				
	M	○				
	K	•				
	N	•				
	S	○				
Точность хвостовика	e9					
Покрытие	BR					
Стандарт	DIN 206					
d, mm	d2mm	l, mm	l2mm	SW	z	STR303001
1,5	1,5	40	20	1,12	3	•
2,0	2,0	49	25	1,60	4	•
2,5	2,5	57	29	2,00	4	•
3,0	3,0	61	31	2,24	4	•
3,5	3,5	70	35	2,80	4	•
4,0	4,0	75	38	3,15	4	•
4,5	4,5	80	41	3,55	6	•
5,0	5,0	86	44	4,00	6	•
6,0	6,0	93	47	4,50	6	•
7,0	7,0	107	54	5,60	6	•
8,0	8,0	115	58	6,30	6	•
9,0	9,0	124	62	7,10	6	•
10,0	10,0	133	45	8,0	6	•
11,0	11,0	142	45	9,0	6	•
12,0	12,0	152	45	10,0	6	•
13,0	13,0	152	45	10,0	6	•
14,0	14,0	163	45	11,2	6	•
15,0	15,0	163	45	11,2	6	•
16,0	16,0	175	56	12,5	6	•
17,0	17,0	175	56	12,5	6	•
18,0	18,0	188	56	14,0	6	•
19,0	19,0	188	56	14,0	6	•
20,0	20,0	201	56	16,0	6	•

Развертки d10,0-20,0 мм с твердосплавным наконечником.

Пример заказа: STR303001 d8,0

Выберите нужный размер и добавьте после артикула.

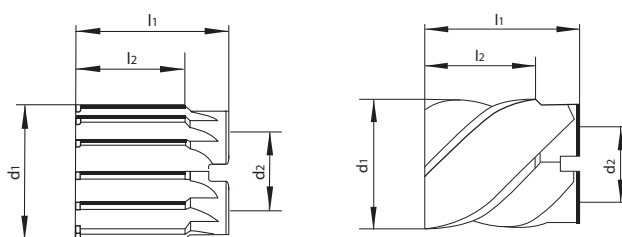

Система обозначений	
d1	диаметр режущей части, мм
d2	диаметр хвостовика, мм
L1	общая длина, мм
L2	длина обнуженной части, мм
L4	длина рабочей части, мм
Z	кол-во зубьев



Все размеры указаны в мм

Группы обрабатываемых материалов Основное применение	P	•	•	•	•	•			
	M	○	○	○	○	○			
Покрытие	K	•	•	•	•	•			
	N	•	•	•	•	•			
	S	○	○	○	○	○			
Стандарт	(BR)	(BR)	(BR)	(BR)	(BR)	(BR)			
d, mm	d2mm	l1 mm	l2mm	z	STR601501	STR601502	STR601503	STR601504	STR602600
20,0	10	50	40	4					
20,0	10	50	40	8	•	•			
21,0	10	50	40	4			•		
21,0	10	50	40	8	•	•			
22,0	10	50	40	4			•		
22,0	10	50	40	8	•	•			
23,0	10	50	40	4			•		
23,0	10	50	40	8	•	•			
24,0	10	50	40	4			•		
24,0	10	50	40	8	•	•			
25,0	13	45	30	6					•
25,0	13	45	32	6			•		
25,0	13	45	32	8	•	•			
26,0	13	45	32	6			•		
26,0	13	45	32	8	•	•			
27,0	13	45	32	6			•		
27,0	13	45	32	8	•	•			
28,0	13	45	32	6			•		
28,0	13	45	32	8	•	•			
29,0	13	45	32	3				•	
29,0	13	45	32	6			•		
29,0	13	45	32	8	•	•			
30,0	13	45	32	3				•	
30,0	13	45	30	6					•
30,0	13	45	32	6			•		
30,0	13	45	32	8	•	•			
31,0	16	50	36	6			•		
31,0	13	45	30	8					•
31,0	16	50	36	10	•	•			
32,0	16	50	36	6			•		
32,0	13	45	30	8					•
32,0	16	50	36	10	•	•			
33,0	16	50	36	6			•		
33,0	16	50	36	10	•	•			
34,0	16	50	36	3				•	
34,0	16	50	36	6			•		
34,0	13	45	30	8					•

Посадочное отверстие с конусностью 1 : 30.

Пример заказа: STR601501 d40,0

Выберите нужный размер и добавьте после артикула.

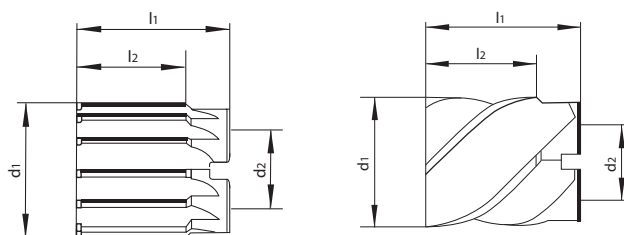

Система обозначений	
d1	диаметр режущей части, мм
d2	диаметр хвостовика, мм
L1	общая длина, мм
L2	длина обниженной части, мм
L4	длина рабочей части, мм
Z	кол-во зубьев



Все размеры указаны в мм

Группы обрабатываемых материалов Основное применение						P				
						M				
						K				
						N				
						S				
Покрытие						(BR)				
Стандарт						DIN 219	DIN 219	DIN 219	DIN 219	DIN 8054
d, mm	d2mm	l1 mm	l2mm	z	STR601501	STR601502	STR601503	STR601504	STR602600	
34,0	16	50	36	10	•	•				
35,0	16	50	36	3				•		
35,0	16	50	36	6			•			
35,0	13	45	30	8					•	
35,0	16	50	36	10	•	•				
36,0	19	56	40	6			•			
36,0	16	50	30	8					•	
36,0	19	56	40	10	•	•				
37,0	19	56	40	6			•			
37,0	16	50	30	8					•	
37,0	19	56	40	10	•	•				
38,0	19	56	40	6			•			
38,0	16	50	30	8					•	
38,0	19	56	40	10	•	•				
39,0	19	56	40	6			•			
39,0	16	50	30	8					•	
39,0	19	56	40	10	•	•				
40,0	19	56	40	5				•		
40,0	19	56	40	6			•			
40,0	16	50	30	8					•	
40,0	19	56	40	10	•	•				
41,0	19	56	40	6			•			
41,0	16	50	30	8					•	
41,0	19	56	40	10	•	•				
42,0	19	56	40	5				•		
42,0	19	56	40	6			•			
42,0	16	50	30	8					•	
42,0	19	56	40	10	•	•				
43,0	22	63	45	6			•			
43,0	16	50	30	8					•	
43,0	22	63	45	12	•	•				
44,0	22	63	45	6			•			
44,0	16	50	30	8					•	
44,0	22	63	45	12	•	•				
45,0	22	63	45	6			•			
45,0	16	50	30	8					•	
45,0	22	63	45	12	•	•				

Посадочное отверстие с конусностью 1 : 30.

Пример заказа: STR601501 d40,0

Выберите нужный размер и добавьте после артикула.

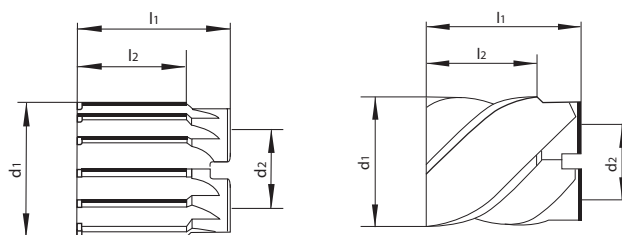

Система обозначений	
d1	диаметр режущей части, мм
d2	диаметр хвостовика, мм
L1	общая длина, мм
L2	длина обнуженной части, мм
L4	длина рабочей части, мм
Z	кол-во зубьев



Все размеры указаны в мм

Группы обрабатываемых материалов Основное применение	P	•	•	•	•	•			
	M	○	○	○	○	○			
	K	•	•	•	•	•			
	N	•	•	•	•	•			
	S	○	○	○	○	○			
Покрытие		BR	BR	BR	BR	BR			
Стандарт		DIN 219	DIN 219	DIN 219	DIN 219	DIN 8054			
d, mm	d2mm	l1 mm	l2mm	z	STR601501	STR601502	STR601503	STR601504	STR602600
46,0	22	63	45	6			•		
46,0	19	56	30	10					•
46,0	22	63	45	12	•	•			
47,0	22	63	45	8			•		
47,0	19	56	30	10					•
47,0	22	63	45	12	•	•			
48,0	22	63	45	8			•		
48,0	19	56	30	10					•
48,0	22	63	45	12	•	•			
49,0	22	63	45	8			•		
49,0	19	56	30	10					•
49,0	22	63	45	12	•	•			
50,0	22	63	45	5				•	
50,0	22	63	45	8			•		
50,0	19	56	30	10					•
50,0	22	63	45	12	•	•			
52,0	27	71	50	8			•		
52,0	19	56	30	10					•
52,0	27	71	50	12	•	•			
54,0	22	63	30	10					•
55,0	27	71	50	8			•		
55,0	22	63	30	10					•
55,0	27	71	50	12	•	•			
56,0	27	71	50	8			•		
56,0	27	71	50	12	•	•			
58,0	27	71	50	8			•		
58,0	22	63	30	10					•
58,0	27	71	50	12	•	•			
60,0	27	71	50	5				•	
60,0	27	71	50	8			•		
60,0	22	63	30	10					•
60,0	27	71	50	12	•	•			
62,0	32	80	56	8			•		
62,0	22	63	30	10					•
62,0	32	80	56	14	•	•			
65,0	32	80	56	8			•		
65,0	27	71	30	12					•

Посадочное отверстие с конусностью 1 : 30.

Пример заказа: STR601501 d40,0

Выберите нужный размер и добавьте после артикула.

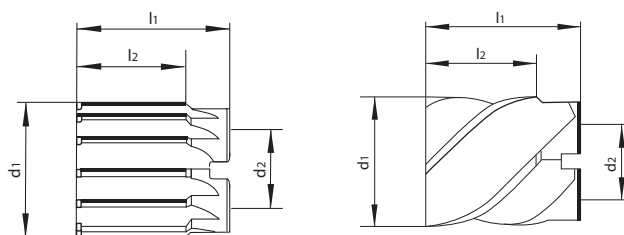

Система обозначений	
d1	диаметр режущей части, мм
d2	диаметр хвостовика, мм
L1	общая длина, мм
L2	длина обнуженной части, мм
L4	длина рабочей части, мм
Z	кол-во зубьев



Все размеры указаны в мм

Группы обрабатываемых материалов Основное применение	P	•	•	•	•	•			
	M	○	○	○	○	○			
	K	•	•	•	•	•			
	N	•	•	•	•	•			
	S	○	○	○	○	○			
Покрытие		BR	BR	BR	BR	BR			
Стандарт		DIN 219	DIN 219	DIN 219	DIN 219	DIN 8054			
d, mm	d2mm	l1 mm	l2mm	z	STR601501	STR601502	STR601503	STR601504	STR602600
65,0	32	80	56	14	•	•			
68,0	32	80	56	8					
68,0	27	71	30	12					•
68,0	32	80	56	14	•	•			
70,0	32	80	56	8			•		
70,0	27	71	30	12					•
70,0	32	80	56	14	•	•			
72,0	40	90	63	8			•		
72,0	27	71	30	12					•
72,0	40	90	63	14	•	•			
75,0	40	90	63	10			•		
75,0	27	71	30	12					•
75,0	40	90	63	14	•	•			
78,0	40	90	63	10			•		
78,0	40	90	63	14	•	•			
80,0	40	90	63	10			•		
80,0	40	90	63	14	•	•			
82,0	40	90	63	10			•		
82,0	40	90	63	14	•	•			
85,0	40	90	63	10			•		
85,0	40	90	63	14	•	•			
88,0	50	100	71	7				•	
88,0	50	100	71	10			•		
88,0	50	100	71	16	•	•			
90,0	50	100	71	10			•		
90,0	50	100	71	16	•	•			
92,0	50	100	71	7				•	
92,0	50	100	71	10			•		
92,0	50	100	71	16	•	•			
95,0	50	100	71	7				•	
95,0	50	100	71	10			•		
95,0	50	100	71	16	•	•			
98,0	50	100	71	7				•	
98,0	50	100	71	10			•		
98,0	50	100	71	16	•	•			
100,0	50	100	71	10			•		
100,0	50	100	71	16	•	•			

Посадочное отверстие с конусностью 1 : 30.
 Пример заказа: STR601501 d40,0
 Выберите нужный размер и добавьте после артикула.

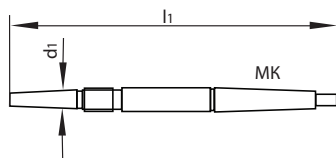

d, mm	l, mm	MK	STR502540
10,0	220	2	•
13,0	250	3	•
16,0	261	3	•
19,0	298	4	•
22,0	312	4	•
27,0	359	5	•
32,1	376	5	•
32,0	396	5	•
40,0	396	5	•
50,0	416	5	•

С конусностью 1 : 30 для насадных разверток

КОМПЛЕКТУЮЩИЕ К ОПРАВКЕ ДЛЯ НАСАДНЫХ РАЗВЕРТОК

Прижимные шайбы

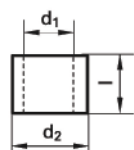

d, mm	l, mm	d2, mm	STR502715
13,0	14	23	•
16,0	16	27	•
19,0	18	32	•
22,0	20	39	•
27,0	21	46	•
32,0	27	56	•
40,0	29	65	•

Поводковые кольца

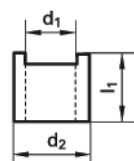

d, mm	l, mm	d2, mm	STR502716
13,0	21	23	•
16,0	23	27	•
19,0	28	32	•
22,0	30	39	•
27,0	35	46	•
32,0	42	56	•
40,0	45	65	•

Сегментные шпонки

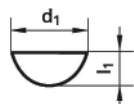

d1, mm	L1, mm	Толщина пластины, mm	STR502717
13	3,7	3	•
16	5	4	•
22	6,5	5	•
27	7,5	6	•
32	9	8	•



Развертки HSSE

Группы обрабатываемых материалов		Vс м/мин	fz мм/об						
			d0,5-4,99	d5,0-7,99	d8,0-11,99	d12,0-19,99	d20,0-29,9	d30,0-39,9	d40,0-60,0
P	стали <500 Н/мм ²	8-16	0,080-0,100	0,100-0,120	0,120-0,160	0,160-0,250	0,250-0,300	0,300-0,360	0,360-0,450
	стали<700 Н/мм ²	8-14	0,080-0,100	0,100-0,120	0,120-0,160	0,160-0,250	0,250-0,300	0,300-0,360	0,360-0,450
	стали<850 Н/мм ²	6-10	0,080-0,100	0,100-0,120	0,120-0,160	0,160-0,250	0,250-0,300	0,300-0,360	0,360-0,450
	стали<1000 Н/мм ²	5-10	0,060-0,080	0,080-0,100	0,100-0,140	0,140-0,200	0,200-0,300	0,300-0,350	0,350-0,450
	стали<1400 Н/мм ²	3-7	0,060-0,080	0,080-0,100	0,100-0,140	0,140-0,200	0,200-0,300	0,300-0,350	0,350-0,450
	цементируемые стали <1000 Н/мм ²	5-10	0,080-0,100	0,100-0,120	0,120-0,160	0,160-0,250	0,250-0,300	0,300-0,360	0,360-0,450
	азотированные стали <1000 Н/мм ²	5-10	0,060-0,080	0,080-0,100	0,100-0,140	0,140-0,200	0,200-0,300	0,300-0,350	0,350-0,450
	термообрабатываемые стали	4-10	0,060-0,080	0,080-0,100	0,100-0,140	0,140-0,200	0,200-0,300	0,300-0,350	0,350-0,450
	инструментальные стали	4-12	0,060-0,080	0,080-0,100	0,100-0,140	0,140-0,200	0,200-0,300	0,300-0,350	0,350-0,450
M	нержавеющие и кислотостойкие стали <700 Н/мм ²	4-8	0,060-0,080	0,080-0,100	0,100-0,140	0,140-0,200	0,200-0,300	0,300-0,350	0,350-0,450
	нержавеющие и кислотостойкие стали >700 Н/мм ²	4-6	0,060-0,080	0,080-0,100	0,100-0,140	0,140-0,200	0,200-0,300	0,300-0,350	0,350-0,450
K	серый чугун <180 HB	8-14	0,120-0,180	0,180-0,200	0,200-0,230	0,230-0,300	0,300-0,350	0,350-0,400	0,400-0,500
	ковкий чугун	5-10	0,100-0,120	0,120-0,160	0,160-0,180	0,180-0,250	0,250-0,300	0,300-0,350	0,350-0,500
N	Al и Al сплавы <6% Si	15-20	0,120-0,180	0,180-0,200	0,200-0,230	0,230-0,300	0,300-0,350	0,350-0,400	0,400-0,650
	Al и Al сплавы <12% Si	10-15	0,120-0,180	0,180-0,200	0,200-0,230	0,230-0,300	0,300-0,350	0,350-0,400	0,400-0,650
	Бронза, медь, латунь	10-17	0,150-0,200	0,200-0,250	0,250-0,320	0,320-0,400	0,400-0,450	0,450-0,500	0,500-0,650
S	Титан, сплавы титана, никель, никелевые сплавы	3-8	0,060-0,080	0,080-0,100	0,100-0,140	0,140-0,200	0,200-0,300	0,300-0,350	0,350-0,450

Развертки VHM

Группы обрабатываемых материалов		Vс м/мин	fz мм/об				
			d1,0-2,99	d3,0-5,99	d6,0-9,99	d10,0-15,99	d16,0-20,0
P	стали <500 Н/мм ²	18-35	0,080-0,100	0,100-0,150	0,150-0,200	0,200-0,250	0,250-0,300
	стали<700 Н/мм ²	18-30	0,080-0,100	0,100-0,150	0,150-0,200	0,200-0,250	0,250-0,300
	стали<850 Н/мм ²	18-30	0,080-0,100	0,100-0,150	0,150-0,200	0,200-0,250	0,250-0,300
	стали<1000 Н/мм ²	13-28	0,060-0,100	0,080-0,100	0,100-0,140	0,140-0,200	0,200-0,300
	стали<1400 Н/мм ²	10-15	0,060-0,080	0,080-0,100	0,100-0,140	0,140-0,200	0,200-0,300
	цементируемые стали <1000 Н/мм ²	12-18	0,080-0,100	0,100-0,120	0,120-0,160	0,160-0,250	0,250-0,300
	азотированные стали <1000 Н/мм ²	12-18	0,060-0,080	0,080-0,100	0,100-0,140	0,140-0,200	0,200-0,300
	термообрабатываемые стали	15-20	0,060-0,080	0,080-0,100	0,100-0,140	0,140-0,200	0,200-0,300
	инструментальные стали	10-15	0,060-0,080	0,080-0,100	0,100-0,140	0,140-0,200	0,200-0,300
M	нержавеющие и кислотостойкие стали <700 Н/мм ²	8-15	0,060-0,080	0,080-0,100	0,100-0,140	0,140-0,200	0,200-0,300
	нержавеющие и кислотостойкие стали >700 Н/мм ²	8-15	0,060-0,080	0,080-0,100	0,100-0,140	0,140-0,200	0,200-0,300
K	серый чугун <180 HB	15-25	0,120-0,180	0,180-0,200	0,200-0,230	0,230-0,300	0,300-0,350
	ковкий чугун	10-18	0,100-0,120	0,120-0,160	0,160-0,180	0,180-0,250	0,250-0,300
N	Al и Al сплавы <6% Si	25-50	0,120-0,180	0,180-0,200	0,200-0,230	0,230-0,300	0,300-0,350
	Al и Al сплавы <12% Si	25-40	0,120-0,180	0,180-0,200	0,200-0,230	0,230-0,300	0,300-0,350
	Бронза, медь, латунь	25-40	0,150-0,200	0,200-0,250	0,250-0,320	0,320-0,400	0,300-0,350
S	Титан, сплавы титана, никель, никелевые сплавы	5-10	0,060-0,080	0,080-0,100	0,100-0,140	0,140-0,200	0,200-0,300

Развертки VHM NC

Группы обрабатываемых материалов	Vc м/мин	fz мм/об					
		d4,0-6,0	d6,0-8,0	d8,0-10,0	d10,0-12,0	d12,0-16,0	
P	стали <500 Н/мм ²	80-120	0,300-0,500	0,500-0,600	0,600-0,800	0,800-0,800	0,800-1,000
	стали <700 Н/мм ²	80-120	0,300-0,500	0,500-0,600	0,600-0,800	0,800-0,800	0,800-1,000
	стали <850 Н/мм ²	80-120	0,300-0,500	0,500-0,600	0,600-0,800	0,800-0,800	0,800-1,000
	стали <1000 Н/мм ²	70-110	0,300-0,400	0,400-0,500	0,600-0,700	0,700-0,800	0,800-0,900
	цементируемые стали <1000 Н/мм ²	70-110	0,300-0,400	0,400-0,500	0,600-0,700	0,700-0,800	0,800-0,900
	азотированные стали <1000 Н/мм ²	70-110	0,300-0,400	0,400-0,500	0,600-0,700	0,700-0,800	0,800-0,900
	термообрабатываемые стали	70-110	0,300-0,400	0,400-0,500	0,600-0,700	0,700-0,800	0,800-0,900
	инструментальные стали	70-110	0,300-0,400	0,400-0,500	0,600-0,700	0,700-0,800	0,800-0,900
M	нержавеющие и кислотостойкие стали <700 Н/мм ²	10-15	0,080-0,100	0,100-0,140	0,120-0,180	0,140-0,200	0,200-0,300
	нержавеющие и кислотостойкие стали >700 Н/мм ²	8-15	0,080-0,100	0,100-0,140	0,120-0,180	0,140-0,200	0,200-0,300
K	серый чугун <180 HB	60-90	0,300-0,500	0,500-0,600	0,600-0,800	0,800-0,800	0,800-1,000
	ковкий чугун	60-90	0,300-0,500	0,500-0,600	0,600-0,800	0,800-0,800	0,800-1,000
N	Al и Al сплавы <6% Si	30-60	0,180-0,200	0,200-0,230	0,220-0,260	0,230-0,300	0,300-0,350
	Al и Al сплавы <12% Si	20-40	0,180-0,200	0,200-0,230	0,220-0,260	0,230-0,300	0,300-0,350
	Бронза, медь, латунь	20-30	0,200-0,250	0,250-0,320	0,270-0,350	0,320-0,400	0,300-0,350
S	Титан, сплавы титана, никель, никелевые сплавы	5-10	0,080-0,100	0,100-0,140	0,120-0,160	0,140-0,200	0,200-0,300

Развертки VHM NC с внутренней подачей СОЖ

Группы обрабатываемых материалов	Vc м/мин	fz мм/об					
		d4,0-6,0	d6,0-8,0	d8,0-10,0	d10,0-12,0	d12,0-16,0	
P	стали <500 Н/мм ²	120-160	0,300-0,650	0,650-1,000	1,000-1,200	1,200-1,200	1,200-1,400
	стали <700 Н/мм ²	120-160	0,300-0,650	0,650-1,000	1,000-1,200	1,200-1,200	1,200-1,400
	стали <850 Н/мм ²	120-160	0,300-0,650	0,650-1,000	1,000-1,200	1,200-1,200	1,200-1,400
	стали <1000 Н/мм ²	110-130	0,300-0,400	0,400-0,500	0,600-0,700	0,700-0,800	0,800-0,900
	цементируемые стали <1000 Н/мм ²	120-140	0,300-0,400	0,400-0,500	0,600-0,700	0,700-0,800	0,800-0,900
	азотированные стали <1000 Н/мм ²	120-140	0,300-0,400	0,400-0,500	0,600-0,700	0,700-0,800	0,800-0,900
	термообрабатываемые стали	120-140	0,300-0,400	0,400-0,500	0,600-0,700	0,700-0,800	0,800-0,900
	инструментальные стали	120-140	0,300-0,400	0,400-0,500	0,600-0,700	0,700-0,800	0,800-0,900
M	нержавеющие и кислотостойкие стали <700 Н/мм ²	10-15	0,080-0,100	0,100-0,140	0,120-0,180	0,140-0,200	0,200-0,300
	нержавеющие и кислотостойкие стали >700 Н/мм ²	8-15	0,080-0,100	0,100-0,140	0,120-0,180	0,140-0,200	0,200-0,300
K	серый чугун <180 HB	80-100	0,300-0,650	0,650-1,000	1,000-1,200	1,200-1,200	1,200-1,400
	ковкий чугун	80-100	0,300-0,650	0,650-1,000	1,000-1,200	1,200-1,200	1,200-1,400
N	Al и Al сплавы <6% Si	30-60	0,180-0,200	0,200-0,230	0,220-0,260	0,230-0,300	0,300-0,350
	Al и Al сплавы <12% Si	20-40	0,180-0,200	0,200-0,230	0,220-0,260	0,230-0,300	0,300-0,350
	Бронза, медь, латунь	20-30	0,200-0,250	0,250-0,320	0,270-0,350	0,320-0,400	0,300-0,350
S	Титан, сплавы титана, никель, никелевые сплавы	5-10	0,080-0,100	0,100-0,140	0,120-0,160	0,140-0,200	0,200-0,300

ДИСКОВЫЕ ПИЛЫ



Группы обрабатываемых материалов		HSS пилы: STS128, STS129, STS130		VHM пилы: STS230, STS231	
		Vc м/мин	Fz мм/З	Vc м/мин	Fz мм/З
P	стали <500 Н/мм ²	40-60	0,02-0,04	150-250	0,010-0,030
	стали <700 Н/мм ²	30-40	0,02-0,04	120-180	0,005-0,025
	стали <850 Н/мм ²	25-35	0,02-0,03	100-180	0,005-0,025
	стали <1000 Н/мм ²	20-30	0,01-0,02	60-120	0,003-0,015
	стали <1400 Н/мм ²	15-25	0,01-0,02	30-60	0,002-0,010
	цементируемые стали <1000 Н/мм ²	20-30	0,01-0,02	70-120	0,004-0,015
	азотированные стали <1000 Н/мм ²	20-30	0,01-0,02	70-120	0,004-0,015
	термообрабатываемые стали	25-35	0,01-0,02	110-180	0,004-0,015
	инструментальные стали	15-25	0,01-0,02	70-120	0,004-0,015
M	нержавеющие и кислотостойкие стали <700 Н/мм ²	8-12	0,01-0,02	70-150	0,005-0,015
	нержавеющие и кислотостойкие стали >700 Н/мм ²	8-12	0,01-0,02	60-120	0,005-0,015
K	серый чугун <180 НВ	20-30	0,02-0,05	100-150	0,005-0,012
	ковкий чугун	30-40	0,02-0,05	100-150	0,005-0,012
N	Al и Al сплавы <6% Si	400-700	0,03-0,07	450-1800	0,015-0,040
	Al и Al сплавы <12% Si	200-500	0,03-0,07	400-1000	0,015-0,040
	Al и Al сплавы >12% Si	150-250	0,02-0,06	300-600	0,010-0,035
	Бронза, медь, латунь	200-300	0,02-0,05	250-600	0,015-0,035
S	Титан, сплавы титана, никель, никелевые сплавы			80-120	0,005-0,015

ОПРАВКИ ДЛЯ ДИСКОВЫХ ПИЛ DIN1835 B



Все посадочные поверхности шлифованные.
Радиальное биение 0,01 мм.
В комплекте зажимной винт и гайка.

Система обозначений	
D	посадочный диаметр, мм
d	диаметр хвостовика, мм
d1	диаметр обнижения оправки, мм
L	общая длина, мм
l	длина обнижения

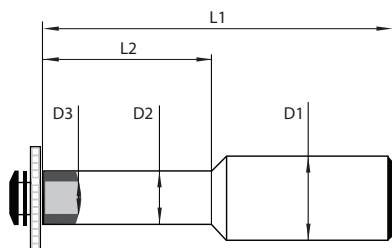

D	Диаметр пилы	d	d1	L	l	Артикул	
						ST	ST
5	20	20	10	90	40	9-30000	-
5	20	20	10	90	30	-	9-30003
8	25	20	13	105	55	9-30001	-
8	25	20	13	100	42	-	9-30004
8	32	20	16	105	53	-	9-30005
10	40	20	20	110	60	9-30002	-
10	40	20	19,5	100	60	-	9-30006
13	50	25	25	136	78	-	9-30007
16	63	25	24,5	136	78	-	9-30008
22	80	25	34	150	92	-	9-30009
22	100	25	39,5	150	92	-	9-30010

Пример заказа:

Для заказа оправки под пилу диаметром 40 мм. посадочным отверстием 10 мм. и общей длиной 100 мм необходимо выбрать арт. ST9-30006



HSS

HSS



HSS форма А



HSS форма В



HSS форма С

P	●
M	○
K	●
N	○
S	○

Система обозначений	
d1	диаметр пилы, мм
d2	посадочное отверстие, мм
b	толщина пилы, мм
z	кол-во зубьев
A	с мелким зубом
B	с крупным зубом
C	с крупным зубом, с черновыми и зачистными зубьями

Тип зубьев	A	B	C
Стандарт	DIN1837A	DIN1838B	DIN1838C
d1 x d2 x b x Z	STS128-	STS129-	STS130-
20x5x0,15x80	..205015		
20x5x0,2x80	..205002		
20x5x0,25x80	..205025		
20x5x0,3x64	..20503		
20x5x0,4x64	..20504		
20x5x0,5x48	..20505		
20x5x0,6x48	..20506		
20x5x0,8x48	..20508		
20x5x0,9x40	..20509		
20x5x1x40	..2051		
20x5x1,2x40	..20512		
20x5x1,5x40	..20515		
20x5x1,6x40	..20516		
20x5x2x32	..2052		
20x5x2,5x32	..20525		
20x5x3x32	..2053		
25x8x0,15x80	..255015		
25x8x0,2x80	..25502		
25x8x0,25x80	..255025		
25x8x0,3x80	..25503		
25x8x0,4x64	..25504		
25x8x0,5x64	..25505		
25x8x0,6x64	..25506		
25x8x0,8x48	..25508		
25x8x0,9x48	..25509		
25x8x1x48	..2551		
25x8x1,2x48	..25512		
25x8x1,6x40	..25516		
25x8x2x40	..2552		
25x8x2,5x40	..25525		
25x8x3x32	..2553		
25x8x4x32	..2554		
25x8x5x32	..2555		
25x8x6x24	..2556		
32x8x0,15x100	..328015		
32x8x0,2x100	..32802		
32x8x0,25x100	..328025		
32x8x0,3x80	..32803		
32x8x0,4x80	..32804		
32x8x0,5x80	..32805		
32x8x0,6x64	..32806		
32x8x0,7x64	..32807		
32x8x0,8x64	..32808		
32x8x0,9x64	..32809		
32x8x1x64	..3281		
32x8x1,2x48	..32812		

Тип зубьев	A	B	C
	DIN1837A	DIN1838B	DIN1838C
d1 x d2 x b x Z	STS128-	STS129-	STS130-
32x8x1,5x48	..32815		
32x8x1,6x48	..32816		
32x8x2x48	..3282		
32x8x2,5x40	..32825		
32x8x3x40	..3283		
32x8x4x40	..3284		
32x8x5x40	..3285		
32x8x6x40	..3286		
40x10x0,2x128	..401002		
40x10x0,25x100	..4010025		
40x10x0,3x100	..401003		
40x10x0,4x100	..401004		
40x10x0,5x80	..401005		
40x10x0,6x80	..401006		
40x10x0,7x80	..401007		
40x10x0,8x80	..401008		
40x10x0,9x80	..401009		
40x10x1x64	..40101		
40x10x1,2x64	..401012		
40x10x1,6x64	..401016		
40x10x2x48	..40102		
40x10x2,5x48	..401025		
40x10x3x48	..40103		
50x13x0,2x48		..501302	
50x13x0,2x128	..501302		
50x13x0,25x48		..5013025	
50x13x0,25x128	..5013025		
50x13x0,3x48		..501303	
50x13x0,3x128	..501303		
50x13x0,4x48		..501304	
50x13x0,4x100	..501304		
50x13x0,5x48		..501305	
50x13x0,5x100	..501305		
50x13x0,6x48		..501306	
50x13x0,6x100	..501306		
50x13x0,7x40		..501307	
50x13x0,7x80	..501307		
50x13x0,8x40		..501308	
50x13x0,8x80	..501308		
50x13x0,9x40		..501309	
50x13x0,9x80	..501309		
50x13x1x40		..50131	..50131
50x13x1x80	..50131		
50x13x1,2x40		..501312	..501312
50x13x1,2x80	..501312		
50x13x1,5x32		..501315	

Тип зубьев	A	B	C
	DIN1837A	DIN1838B	DIN1838C
d1 x d2 x b x Z	STS128-	STS129-	STS130-
50x13x1,5x64	..501315		
50x13x1,6x32		..501316	..501316
50x13x1,6x64	..501316		
50x13x2x32		..50132	..50132
50x13x2x64	..50132		
50x13x2,5x32		..501325	..501325
50x13x2,5x64	..501325		
50x13x3x24		..50133	..50133
50x13x3x48	..50133		
50x13x4x24		..50134	..50134
50x13x4x48	..50134		
50x13x5x24		..50135	..50135
50x13x5x48	..50135		
63x16x0,25x64		..6316025	
63x16x0,25x160	..6316025		
63x16x0,3x64		..631603	
63x16x0,3x128	..631603		
63x16x0,4x64		..631604	
63x16x0,4x128	..631604		
63x16x0,5x64		..631605	
63x16x0,5x128	..631605		
63x16x0,6x48		..631606	
63x16x0,6x100	..631606		
63x16x0,7x48		..631607	
63x16x0,7x100	..631607		
63x16x0,8x48		..631608	
63x16x0,8x100	..631608		
63x16x0,9x48		..631609	
63x16x0,9x100	..631609		
63x16x1x48		..63161	..63161
63x16x1x100	..63161		
63x16x1,2x40		..631612	..631612
63x16x1,3x80	..631602		
63x16x1,5x40		..631615	
63x16x1,5x80	..631615		
63x16x1,6x40		..631616	..631616
63x16x1,6x80	..631616		
63x16x2x40		..63162	..63162
63x16x2x80	..63162		
63x16x2,5x32		..631625	..631625
63x16x2,5x64	..631625		
63x16x3x32		..63163	..63163
63x16x3x64	..63163		
63x16x3,5x32		..631635	
63x16x3,5x64	..631635		
63x16x4x32		..63164	..63164

HSS



P	●
M	○
K	●
N	○
S	○

Система обозначений	
d1	диаметр пилы, мм
d2	посадочное отверстие, мм
b	толщина пилы, мм
z	кол-во зубьев
A	с мелким зубом
B	с крупным зубом
C	с крупным зубом, с черновыми и зачистными зубьями



HSS форма A



HSS форма B



HSS форма C

Тип зубьев Стандарт	A	B	C
	DIN1837A	DIN1838B	DIN1838C
d1 x d2 x b x Z	STS128-	STS129-	STS130-
63x16x4x64	..63164		
63x16x5x24		..63165	..63165
63x16x5x48	..63165		
63x16x6x24		..63166	..63166
63x16x6x48	..63166		
80x22x0,3x64		..802203	
80x22x0,3x160	..802203		
80x22x0,4x64		..802204	
80x22x0,4x160	..802204		
80x22x0,5x64		..802205	
80x22x0,5x128	..802205		
80x22x0,6x64		..802206	
80x22x0,6x128	..802206		
80x22x0,7x64		..802207	
80x22x0,7x128	..802207		
80x22x0,8x64		..802208	
80x22x0,8x128	..802208		
80x22x0,9x48		..802209	
80x22x0,9x100	..802209		
80x22x1x48		..80221	..80221
80x22x1x100	..80221		
80x22x1,2x48		..802212	..80221
80x22x1,2x100	..802212		
80x22x1,5x100	..802215		
80x22x1,5x48		..802215	
80x22x1,6x48		..802216	..802216
80x22x1,6x100	..802216		
80x22x2x40		..80222	..80222
80x22x2x80	..80222		
80x22x2,5x40		..802225	..802225
80x22x2,5x80	..802225		
80x22x3x40		..80223	..80223
80x22x3x80	..80223		
80x22x3,5x32		..802235	
80x22x3,5x64	..802235		
80x22x4x32		..80224	..80224
80x22x4x64	..80224		
80x22x5x32		..80225	..80225
80x22x5x64	..80225		
80x22x6x32		..80226	..80226
80x22x6x64	..80226		
100x22x0,4x80		..1002204	
100x22x0,4x160	..1002204		
100x22x0,5x80		..1002205	
100x22x0,5x160	..1002205		
100x22x0,6x80		..1002206	

	A	B	C
	DIN1837A	DIN1838B	DIN1838C
d1 x d2 x b x Z	STS128-	STS129-	STS130-
100x22x0,6x160	..1002206		
100x22x0,7x80		..1002207	
100x22x0,7x64	..1002207		
100x22x0,8x64		..1002208	
100x22x0,8x128	..1002208		
100x22x0,9x64		..1002209	
100x22x0,9x128	..1002209		
100x22x1x64		..100221	..100221
100x22x1x128	..100221		
100x22x1,2x64		..1002212	..1002212
100x22x1,2x128	..1002212		
100x22x1,5x100	..1002215		
100x22x1,5x100		..1002215	
100x22x1,6x48		..1002216	..1002216
100x22x1,6x100	..1002216		
100x22x2x48		..100222	..100222
100x22x2x100	..100222		
100x22x2,5x48		..1002225	..1002225
100x22x2,5x100	..1002225		
100x22x3x40		..100223	..100223
100x22x3x80	..100223		
100x22x3,5x80	..1002235		
100x22x3,5x40		..1002235	
100x22x4x40		..100224	..100224
100x22x4x80	..100224		
100x22x5x40		..100225	..100225
100x22x5x80	..100225		
100x22x6x32		..100226	..100226
100x22x6x64	..100226		
125x22x0,5x80		..1252205	
125x22x0,5x160	..1252205		
125x22x0,6x80		..1252206	
125x22x0,6x160	..1252206		
125x22x0,7x80		..1252207	
125x22x0,7x160	..1252207		
125x22x0,8x80		..1252208	
125x22x0,8x160	..1252208		
125x22x0,9x80		..1252209	
125x22x0,9x160	..1252209		
125x22x1x80		..125221	..125221
125x22x1x160	..125221		
125x22x1,2x64		..1252212	..1252212
125x22x1,2x128	..1252212		
125x22x1,5x64		..1252215	
125x22x1,5x128	..1252215		
125x22x1,6x64		..1252216	..1252216

	A	B	C
	DIN1837A	DIN1838B	DIN1838C
d1 x d2 x b x Z	STS128-	STS129-	STS130-
125x22x1,6x128	..1252216		
125x22x2x64		..125222	..125222
125x22x2x128	..125222		
125x22x2,5x48		..1252225	..1252225
125x22x2,5x100	..1252225		
125x22x3x48		..125223	..125223
125x22x3x100	..125223		
125x22x3,2x48		..1252232	
125x22x3,2x100	..1252232		
125x22x3,5x48		..1252235	
125x22x3,5x100	..1252235		
125x22x4x48		..125224	..125224
125x22x4x100	..125224		
125x22x5x40		..125225	..125225
125x22x5x80	..125225		
125x22x6x40		..125226	..125226
125x22x6x80	..125226		
160x32x1x80		..160321	..160321
160x32x1x160			
160x32x1,2x80		..1603212	..1603212
160x32x1,2x160	..1603212		
160x32x1,5x80		..1603215	
160x32x1,5x160	..1603215		
160x32x1,6x80		..1603216	..1603216
160x32x1,6x160	..1603216		
160x32x2x64		..160322	..160322
160x32x2x128	..160322		
160x32x2,5x64		..1603225	..1603225
160x32x2,5x128	..1603225		
160x32x3x64		..160323	..160323
160x32x3x128	..160323		
160x32x3,5x48		..1603235	
160x32x3,5x100	..1603235		
160x32x4x48		..160324	..160324
160x32x4x100	..160324		
160x32x4,5x48		..1603245	
160x32x4,5x100	..1603245		
160x32x5x48		..160325	..160325
160x32x5x100	..160325		
160x32x6x48		..160326	..160326
160x32x6x100	..160326		
200x32x1x100		..200321	..200321
200x32x1,2x100		..2003212	..2003212
200x32x1,2x200	..2003212		
200x32x1,5x80		..2003215	
200x32x1,5x200	..2003215		

ДИСКОВЫЕ ПИЛЫ

HSS

Система обозначений	
d1	диаметр пилы, мм
d2	посадочное отверстие, мм
b	толщина пилы, мм
z	кол-во зубьев
A	с мелким зубом
B	с крупным зубом
C	с крупным зубом, с черновыми и зачистными зубьями

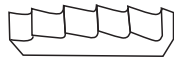

P	•
M	○
K	•
N	•
S	○



HSS форма А



HSS форма В



HSS форма С

Тип зубьев Стандарт	A	B	C
	DIN1837A	DIN1838B	DIN1838C
d1 x d2 x b x Z	STS128-	STS129-	STS130-
200x32x1,6x80	..2003216	..2003216	..2003216
200x32x1,6x160	..2003216		
200x32x1,8x80		..2003218	
200x32x1,8x160	..2003218		
200x32x2x80		..2003222	..2003222
200x32x2x160	..2003222		
200x32x2,5x80		..2003225	..2003225
200x32x2,5x160	..2003225		
200x32x3x64		..2003232	..2003232
200x32x3x128	..2003232		
200x32x3,5x64		..2003235	
200x32x3,5x128	..2003235		
200x32x4x64		..2003242	..2003242
200x32x4x128	..2003242		
200x32x4,5x64		..2003245	
200x32x4,5x128	..2003245		
200x32x5x64		..2003252	..2003252
200x32x5x128	..2003252		
200x32x5,5x48		..2003255	
200x32x5,5x128	..2003255		
200x32x6x48		..2003262	..2003262
200x32x6x100	..2003262		
225x32x1,5x200	..2253215		
225x32x1,5x80		..2253215	
225x32x1,6x200	..2253216		
225x32x1,6x80		..2253216	
225x32x1,8x200	..2253218		
225x32x1,8x80		..2253218	
225x32x2x160	..2253222		
225x32x2x80		..2253222	
225x32x2,5x160	..2253..225		
225x32x2,5x80		..2253..225	

	A	B	C
	DIN1837A	DIN1838B	DIN1838C
d1 x d2 x b x Z	STS128-	STS129-	STS130-
225x32x3x160	..2253232		
225x32x3x64		..2253232	
225x32x3,5x160	..2253235		
225x32x3,5x128		..2253235	
225x32x4x200	..2253242		
225x32x4x100		..2253242	
250x32x1,5x100		..2503215	
250x32x1,5x200	..2503215		
250x32x1,6x100		..2503216	..2503216
250x32x1,6x200	..2503216		
250x32x2x80			..2503222
250x32x2x100		..2503222	
250x32x2x200	..2503222		
250x32x2,5x80		..2503225	..2503225
250x32x2,5x160	..2503225		
250x32x3x80		..2503232	..2503232
250x32x3x160	..2503232		
250x32x3,5x80		..2503235	
250x32x3,5x160	..2503235		
250x32x4x80		..2503242	..2503242
250x32x4x160	..2503242		
250x32x4,5x64		..2503245	
250x32x4,5x128	..2503245		
250x32x5x64		..2503252	..2503252
250x32x5x128	..2503252		
250x32x5,5x128		..2503255	
250x32x5,5x128	..2503255		
250x32x6x64		..2503262	..2503262
250x32x6x128	..2503262		
275x32x1,75x200	..27532175		
275x32x1,75x100		..27532175	
275x32x2x200	..2753222		

	A	B	C
	DIN1837A	DIN1838B	DIN1838C
d1 x d2 x b x Z	STS128-	STS129-	STS130-
275x32x2x100		..2503222	
275x32x2,5x160	..2753225		
275x32x2,5x80		..2503225	
275x32x3x160	..2753232		
275x32x3x80		..2753232	
275x32x3,5x160	..2753235		
275x32x3,5x80		2753235	
285x32x2x100		..2853222	
285x32x2x200	..2853222		
300x32x2x200	..3003222		
300x32x2x100		..3003222	
300x32x2,5x200	..3003225		
300x32x2,5x80		..3003225	
300x32x3x200	..3003232		
300x32x3x80		..3003232	
300x32x3,5x200	..3003235		
300x32x3,5x80		..3003235	
300x40x3,5x80		..3004035	
300x40x3,5x200	..3004035		
315 x 40 x 2 x 100		..315402	
315x40x2x200	..315402		
315x40x2,5x100		..3154025	
315x40x2,5x200	..3154025		
315x40x3x100		..3154023	..3154023
315x40x3x200	..3154023		
315x40x4x80		..315404	..315404
315x40x4x160	..315404		
315x40x4,5x160	..3154045		
315x40x5x80		..315405	..315405
315x40x5x160	..315405		
315x40x6x80		..315406	..315406
315x40x6x160	..315406		

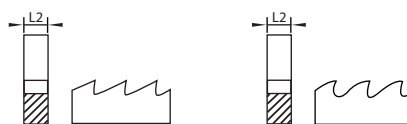
VHM

VHM форма A



VHM форма B

P	●
M	●
K	●
N	●
S	●

Система обозначений	
d1	диаметр пилы, мм
d2	посадочное отверстие, мм
b	толщина пилы, мм
z	кол-во зубьев
A	с мелким зубом
B	с крупным зубом

Тип зубьев Стандарт	A		B	
	DIN1837A	DIN1837B	DIN1837A	DIN1837B
d1 x d2 x b x Z	STS230-	STS231-		
15x5x0,1x64	..15501			
15x5x0,15x64	..155015			
15x5x0,2x20		..15501		
15x5x0,2x64	..15502			
15x5x0,25x64	..155025			
15x5x0,3x20		..15502		
15x5x0,3x64	..15503			
15x5x0,4x20		..15503		
15x5x0,4x64	..15504			
15x5x0,5x20		..15504		
15x5x0,5x48	..15505			
15x5x0,6x20		..15505		
15x5x0,6x48	..15506			
15x5x0,7x20		..15506		
15x5x0,7x48	..15507			
15x5x0,8x20		..15507		
15x5x0,8x40	..15508			
15x5x0,9x40	..15509			
15x5x1x20		..15510		
15x5x1x40	..15510			
15x5x1,1x40	..15511			
15x5x1,2x20		..15512		
15x5x1,2x40	..15512			
15x5x1,3x40	..15513			
15x5x1,4x40	..15514			
15x5x1,5x20		..15515		
15x5x1,5x40	..15515			
15x5x1,6x20		..15516		
15x5x1,6x40	..15516			
15x5x1,7x40	..15517			
15x5x1,8x20		..15518		
15x5x1,8x40	..15518			
15x5x1,9x40	..15519			
15x5x2x20		..15520		
15x5x2,1x40	..15520			
15x5x2,5x20		..15525		
15x5x2,5x40	..15525			
15x5x3x20		..15530		
15x5x3x99	..15530			
15x5x3,5x40	..15535			
15x5x4x20		..15540		
15x5x4x40	..15540			
15x5x5x20		..15550		
15x5x5x40	..15550			
15x5x6x20		..15560		
15x5x6x40	..15560			
20x5x0,1x80	..20501			
20x5x0,2x20		..20502		
20x5x0,2x80	..20502			
20x5x0,3x20		..20503		

d1 x d2 x b x Z	A		B	
	STS230-	STS231-	DIN1837A	DIN1837B
20x5x0,3x64	..20503			
20x5x0,4x20		..20504		
20x5x0,4x64	..20504			
20x5x0,5x20		..20505		
20x5x0,5x48	..20505			
20x5x0,6x20		..20506		
20x5x0,6x48	..20506			
20x5x0,7x20		..20507		
20x5x0,7x48	..20507			
20x5x0,8x20		..20508		
20x5x0,8x48	..20508			
20x5x0,9x40	..20509			
20x5x1x20		..20510		
20x5x1x40	..20510			
20x5x1,1x40	..20511			
20x5x1,2x20		..20512		
20x5x0,2x40	..20512			
20x5x1,3x40	..20513			
20x5x1,4x40	..20514			
20x5x1,5x20		..20515		
20x5x1,5x40	..20515			
20x5x1,6x20		..20516		
20x5x1,6x40	..20516			
20x5x1,7x40	..20517			
20x5x1,8x20		..20518		
20x5x1,8x32	..20518			
20x5x1,9x32	..20519			
20x5x2x20		..20520		
20x5x2x32	..20520			
20x5x2,5x20		..20525		
20x5x2,5x32	..20525			
20x5x3x20		..20530		
20x5x3x32	..20530			
20x5x3,5x24	..20535			
20x5x4x20		..20540		
20x5x4x24	..20540			
20x5x5x20		..20550		
20x5x5x24	..20550			
20x5x6x20		..20560		
20x5x6x24	..20560			
25x5x0,1x80	..25501			
25x8x0,2x20		..25502		
25x5x0,2x80	..25502			
25x8x0,3x20		..25503		
25x5x0,3x80	..25503			
25x8x0,4x20		..25504		
25x5x0,4x64	..25504			
25x8x0,5x20		..25505		
25x5x0,5x64	..25505			
25x8x0,6x20		..25506		

d1 x d2 x b x Z	A		B	
	STS230-	STS231-	DIN1837A	DIN1837B
25x5x0,6x64	..25506			
25x8x0,7x20		..25507		
25x5x0,7x48	..25507			
25x8x0,8x20		..25508		
25x5x0,8x48	..25508			
25x5x0,9x48	..25509			
25x8x1x20		..25510		
25x5x1x48	..25510			
25x5x1,1x48	..25511			
25x8x1,2x20		..25512		
25x5x1,2x48	..25512			
25x5x1,3x40	..25513			
25x5x1,4x40	..25514			
25x8x1,5x20		..25515		
25x5x1,5x40	..25515			
25x8x1,6x20		..25516		
25x5x1,6x40	..25516			
25x5x1,7x40	..25517			
25x8x1,8x20		..25518		
25x5x1,8x40	..25518			
25x5x1,9x40	..25519			
25x8x2x20		..25520		
25x5x2x40	..25520			
25x8x2,5x20		..25525		
25x5x2,5x40	..25525			
25x8x3x20		..25530		
25x5x3x32	..25530			
25x5x3,5x32	..25535			
25x8x4x20		..25540		
25x5x4x32	..25540			
25x8x5x20		..25550		
25x5x5x32	..25550			
25x8x6x20		..25560		
25x5x6x32	..25560			
30x8x0,1x100	..30801			
30x8x0,2x30		..30802		
30x8x0,2x100	..30802			
30x8x0,3x30		..30803		
30x8x0,3x80	..30803			
30x8x0,4x30		..30804		
30x8x0,4x80	..30804			
30x8x0,5x30		..30805		
30x8x0,5x80	..30805			
30x8x0,6x30		..30806		
30x8x0,6x64	..30806			
30x8x0,7x30		..30807		
30x8x0,7x64	..30807			
30x8x0,8x30		..30808		
30x8x0,8x64	..30808			
30x8x0,9x64	..30809			

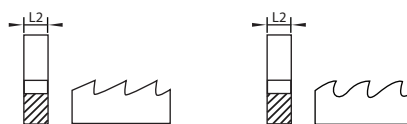

Система обозначений	
d1	диаметр пилы, мм
d2	посадочное отверстие, мм
b	толщина пилы, мм
z	кол-во зубьев
A	с мелким зубом
B	с крупным зубом



VHM форма A



VHM форма B

P	●
M	●
K	●
N	●
S	●

Тип зубьев Стандарт	A		B	
	DIN1837A	DIN1837B	DIN1837A	DIN1837B
d1 x d2 x b x Z	STS230-	STS231-		
30x8x1,1x24		..30810		
30x8x1,1x64	..30810			
30x8x1,1x64	..30811			
30x8x1,2x24		..30812		
30x8x1,2x48	..30812			
30x8x1,3x24		..30813		
30x8x1,3x48	..30813			
30x8x1,4x24		..30814		
30x8x1,4x48	..30814			
30x8x1,5x24		..30815		
30x8x1,5x48	..30815			
30x8x1,6x24		..30816		
30x8x1,6x48	..30816			
30x8x1,7x48	..30817			
30x8x1,8x24		..30818		
30x8x1,8x48	..30818			
30x8x1,9x48	..30819			
30x8x2x24		..30820		
30x8x2x48	..30820			
30x8x2,5x24		..30825		
30x8x2,5x40	..30825			
30x8x3x24		..30830		
30x8x3x40	..30830			
30x8x3,5x40	..30835			
30x8x4x24		..30840		
30x8x4x40	..30840			
30x8x5x24		..30850		
30x8x5x32	..30850			
30x8x6x24		..30860		
30x8x6x32	..30860			
40x10x0,15x40	..4010015			
40x10x0,2x40	..401002	..401002		
40x10x0,3x40		..401003		
40x10x0,3x100	..401003			
40x10x0,4x40		..401004		
40x10x0,4x100	..401004			
40x10x0,5x40		..401005		
40x10x0,5x80	..401005			
40x10x0,6x40		..401006		
40x10x0,6x80	..401006			
40x10x0,7x40		..401007		
40x10x0,7x80	..401007			
40x10x0,8x32		..401008		
40x10x0,8x80	..401008			
40x10x0,9x64	..401009			
40x10x1x32		..401010		
40x10x1x64	..401010			
40x10x1,1x64	..401011			
40x10x1,2x32		..401012		
40x10x1,2x64	..401012			

d1 x d2 x b x Z	A		B	
	STS230-	STS231-	DIN1837A	DIN1837B
40x10x1,3x64	..401013			
40x10x1,4x64	..401014			
40x10x1,5x32		..401015		
40x10x1,5x64	..401015			
40x10x1,6x32		..401016		
40x10x1,6x64	..401016			
40x10x1,7x48	..401017			
40x10x1,8x32		..401018		
40x10x1,8x48	..401018			
40x10x1,9x48	..401019			
40x10x2x32		..40102		
40x10x3x48	..40102			
40x10x2,5x32		..401025		
40x10x2,5x48	..401025			
40x10x3x32		..40103		
40x10x3x48	..40103			
40x10x3,5x48	..401035			
40x10x4x32		..40104		
40x10x4x40	..40104			
40x10x5x32		..40105		
40x10x5x40	..40105			
40x10x6x32		..40106		
40x10x6x40	..40106			
50x13x0,2x128	..501302			
50x13x0,3x128	..501303			
50x13x0,2x48		..501302		
50x13x0,25x48		..5013025		
50x13x0,3x48		..501303		
50x13x0,4x48		..501304		
50x13x0,4x100	..501304			
50x13x0,5x48		..501305		
50x13x0,5x100	..501305			
50x13x0,6x48		..501306		
50x13x0,6x100	..501306			
50x13x0,7x40		..501307		
50x13x0,7x80	..501307			
50x13x0,8x40		..501308		
50x13x0,8x80	..501308			
50x13x0,9x80	..501309			
50x13x1x40		..50131		
50x13x1x80	..50131			
50x13x1,1x80	..501311			
50x13x1,2x40		..501312		
50x13x1,2x80	..501312			
50x13x1,3x64	..501313			
50x13x1,4x64	..501314			
50x13x1,5x32		..501315		
50x13x1,5x64	..501315			
50x13x1,6x32		..501316		
50x13x1,6x64	..501316			

d1 x d2 x b x Z	A		B	
	STS230-	STS231-	DIN1837A	DIN1837B
50x13x1,7x64	..501317			
50x13x1,8x32		..501318		
50x13x1,8x64	..501318			
50x13x1,9x64	..501319			
50x13x2x32		..50132		
50x13x3x64	..50132			
50x13x2,5x32		..501325		
50x13x2,5x64	..501325			
50x13x3x24		..50133		
50x13x3x48	..50133			
50x13x3,5x48	..501335			
50x13x4x24		..50134		
50x13x4x48	..50134			
50x13x5x24		..50135		
50x13x5x48	..50135			
50x13x6x24		..50136		
50x13x6x48	..50136			
63x16x0,2x160	..631602			
63x16x0,25x160	..6316025			
63x16x0,3x128	..631603			
63x16x0,4x64		..631604		
63x16x0,4x128	..631604			
63x16x0,5x64		..631605		
63x16x0,5x128	..631605			
63x16x0,6x48		..631606		
63x16x0,6x100	..631606			
63x16x0,7x48		..631607		
63x16x0,7x100	..631607			
63x16x0,8x48		..631608		
63x16x0,8x100	..631608			
63x16x0,9x100	..631609			
63x16x1x48		..63161		
63x16x1x100	..63161			
63x16x1,1x80	..631611			
63x16x1,2x40		..631612		
63x16x1,3x80	..631612			
63x16x1,3x80	..631613			
63x16x1,4x80	..631614			
63x16x1,5x40		..631615		
63x16x1,5x80	..631615			
63x16x1,6x40		..631616		
63x16x1,6x80	..631616			
63x16x1,7x80	..631617			
63x16x1,8x40		..631618		
63x16x1,8x80	..631618			
63x16x1,9x80	..631619			
63x16x2x40		..63162		
63x16x2x80	..63162			
63x16x2,5x40		..631625		
63x16x2,5x64	..631625			

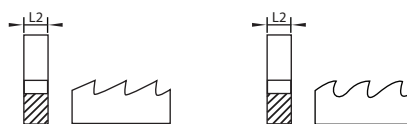

Система обозначений	
d1	диаметр пилы, мм
d2	посадочное отверстие, мм
b	толщина пилы, мм
z	кол-во зубьев
A	с мелким зубом
B	с крупным зубом



VHM форма A



VHM форма B

P	●
M	●
K	●
N	●
S	●

Тип зубьев	A	B
Стандарт	DIN1837A	DIN1837B
d1 x d2 x b x Z	STS230-	STS231-
63x16x3x32		..63163
63x16x3x64	..63163	
63x16x3,5x64	..631635	
63x16x4x32		..63164
63x16x4x64	..63164	
63x16x5x24		..63165
63x16x5x48	..63165	
63x16x6x24		..63166
63x16x6x48	..63166	
80x22x0,3x160	..802203	
80x22x0,3x64		..802203
80x22x0,4x160	..802204	
80x22x0,4x64		..802204
80x22x0,5x128	..802205	
80x22x0,5x64		..802205
80x22x0,6x64		..802206
80x22x0,6x128	..802206	
80x22x0,7x64		..802207
80x22x0,7x128	..802207	
80x22x0,8x64		..802208
80x22x0,8x128	..802208	
80x22x0,9x100	..802209	
80x22x1x48		..80221
80x22x1x100	..80221	
80x22x1,1x100	..802211	
80x22x1,2x48		..802212
80x22x1,2x100	..802212	
80x22x1,3x100	..802213	
80x22x1,4x100	..802214	
80x22x1,5x48		..802215
80x22x1,5x100	..802215	
80x22x1,6x48		..802216
80x22x1,6x100	..802216	
80x22x1,1x109	..802217	
80x22x1,8x40		..802218
80x22x1,8x80	..802218	
80x22x1,9x80	..802219	
80x22x2x40		..80222
80x22x2x80	..80222	
80x22x2,5x40		..802225
80x22x2,5x80	..802225	
80x22x3x40		..80223
80x22x3x80	..80223	
80x22x3,5x64	..802235	
80x22x4x32		..80224
80x22x4x64	..80224	
80x22x5x32		..80225
80x22x5x64	..80225	
80x22x6x32		..80226
80x22x6x64	..80226	

	A	B
	DIN1837A	DIN1837B
d1 x d2 x b x Z	STS230-	STS231-
100x22x0,5x160	..1002205	
100x22x0,5x80		..1002205
100x22x0,6x80		..1002206
100x22x0,6x160	..1002206	
100x22x0,7x80		..1002207
100x22x0,7x64	..1002207	
100x22x0,8x64		..1002208
100x22x0,8x128	..1002208	
100x22x0,9x128	..1002209	
100x22x1x64		..100221
100x22x1x128	..100221	
100x22x1,1x128	..1002211	
100x22x1,2x64		..1002212
100x22x1,2x128	..1002212	
100x22x1,3x100	..1002213	
100x22x1,4x100	..1002214	
100x22x1,5x48		..1002215
100x22x1,5x100	..1002215	
100x22x1,6x48		..1002216
100x22x1,6x100	..1002216	
100x22x1,7x100	..1002217	
100x22x1,8x48		..1002218
100x22x1,8x100	..1002218	
100x22x1,9x100	..1002219	
100x22x2x48		..100222
100x22x2x100	..100222	
100x22x2,5x48		..1002225
100x22x2,5x100	..1002225	
100x22x3x40		..100223
100x22x3x80	..100223	
100x22x3,5x80	..1002235	
100x22x4x40		..100224
100x22x4x80	..100224	
100x22x5x40		..100225
100x22x5x80	..100225	
100x22x6x32		..100226
100x22x6x64	..100226	
125x22x0,6x80		..1252206
125x22x0,7x160	..1252207	
125x22x0,8x80		1252208
125x22x0,8x160	..1252208	
125x22x0,9x160	..1252209	
125x22x1x80		..125221
125x22x1x160	..125221	
125x22x1,1x128	..1252211	
125x22x1,2x64		..1252212
125x22x1,2x128	..1252212	
125x22x1,3x128	..1252213	
125x22x1,4x128	..1252214	
125x22x1,5x64		..1252215

	A	B
	DIN1837A	DIN1837B
d1 x d2 x b x Z	STS230-	STS231-
125x22x1,5x128	..1252215	
125x22x1,6x64		..1252216
125x22x1,6x128	..1252216	
125x22x1,7x128	..1252217	
125x22x1,8x64		..1252218
125x22x1,8x128	..1252218	
125x22x1,9x128	..1252219	
125x22x2x64		..125222
125x22x2x128	..125222	
125x22x2,5x48		..1252225
125x22x2,5x100	..1252225	
125x22x3x48		..125223
125x22x3x100	..125223	
125x22x3,5x100	..1252235	
125x22x4x48		..125224
125x22x4x100	..125224	
125x22x5x40		..125225
125x22x5x80	..125225	
125x22x6x40		..125226
125x22x6x80	..125226	
150x32x1x150	..150321	
150x32x1,2x150	..1503212	
150x32x1,3x155	..1503215	
150x32x1,6x150	..1503216	
150x32x2x128	..150322	
150x32x2,5x128	..1503225	
150x32x3x128	..150323	
150x32x4x128	..150324	
160x32x1x160	..160321	
160x32x1x80		..160321
160x32x1,2x80		..1603212
160x32x1,2x160	..1603212	
160x32x1,5x80		..1603215
160x32x1,5x160	..1603215	
160x32x1,6x80		..1603216
160x32x1,6x160	..1603216	
160x32x2x64		..160322
160x32x2x128	..160322	
160x32x2,5x64		..1603225
160x32x2,5x128	..1603225	
160x32x3x64		..160323
160x32x3x128	..160323	
160x32x4x80		..160324
160x32x4x100	..160324	
200x32x1,5x160	..2003215	
200x32x1,6x160	..2003216	
200x32x2x160	..200322	
200x32x2,5x160	..2003225	
200x32x3x128	..200323	
200x32x4x128	..200324	